

LOC	DIST	REVISIONS			
P	LTR	DESCRIPTION	DATE	DWN	APVD
AF	50	F	REVISED PER ECR-11-018063	22DEC11	KH PD

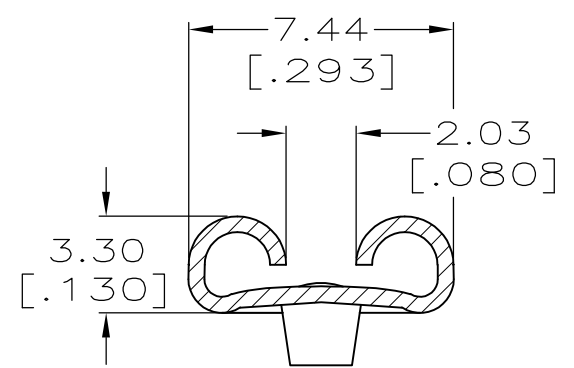

SECTION A-A

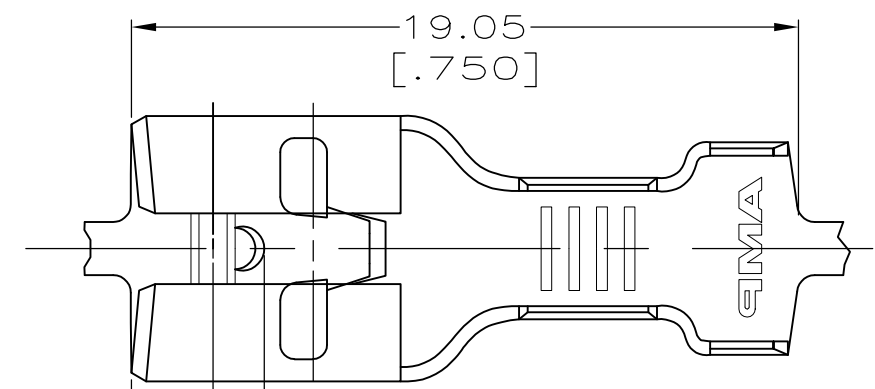
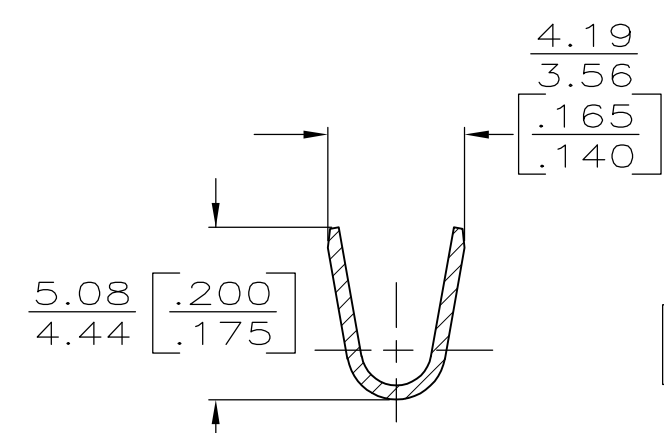
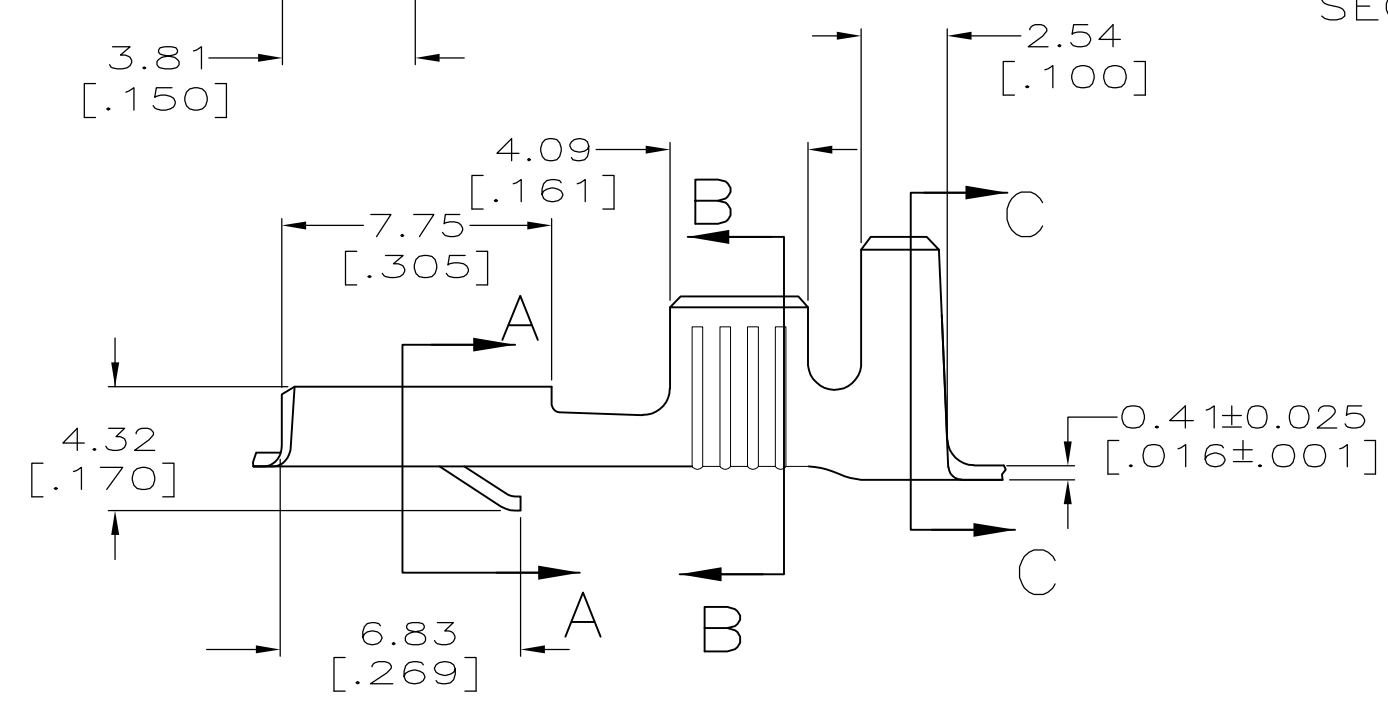

SECTION B-B

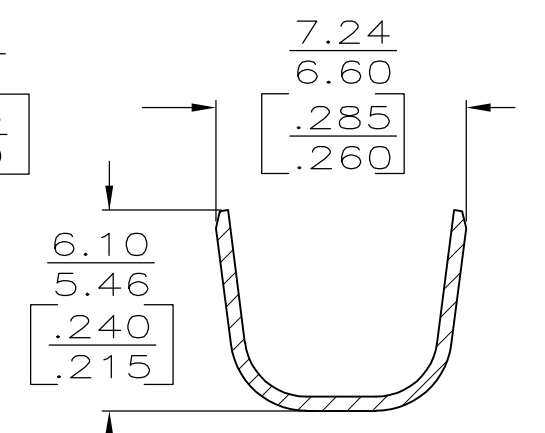

SECTION C-C

- 1 CONTINUOUS STRIP ON REELS.
- 2 ACCEPTS WIRE SIZE [#16-#12 OR TWO #16'S].
- 3 INSULATION RANGE TO BE 4.06-5.33 [.160-.210] OR TWO 3.30 [.130] MAX DIA.
- 4 MATING TAB THK IS 0.81±0.025 [.032±.001].
- △5 INTERLEAVING PAPER REQUIRED.
- △6 PRELIMINARY - NOT FOR PRODUCTION

△5	0.002032 [.000080] MIN TIN	△6	60249-5
	0.000381 [.000015] THK SILVER		60249-3
	TIN		60249-2
	-		60249-1
	FINISH		PART NO

THIS DRAWING IS A CONTROLLED DOCUMENT.		DWN	JR RUTH	7/14/95	<b>STE</b> TE Connectivity			
DIMENSIONS: mm [INCHES]		CHK	MS FEHER	7/14/95				
TOLERANCES UNLESS OTHERWISE SPECIFIED:		APVD	J GILLESPIE	7/14/95	NAME RECEPTACLE, FASTIN-FASTON, 6.35 [.250] SERIES			
0 PLC ± -		PRODUCT SPEC	-					
1 PLC ± -		APPLICATION SPEC	114-2025		SIZE	CAGE CODE	DRAWING NO	RESTRICTED TO
2 PLC ± 0.38 [.015]		WEIGHT	-		A3	00779	C-60249	-
3 PLC ± -		CUSTOMER DRAWING		SCALE	5:1	SHEET	1 of 1	REV
4 PLC ± -		MATERIAL H04 BRASS						F
FINISH SEE TABLE								
ANGLES ± -								