

# DFS60B-BHPA10000

DFS60

INCREMENTAL ENCODERS

**SICK**  
Sensor Intelligence.

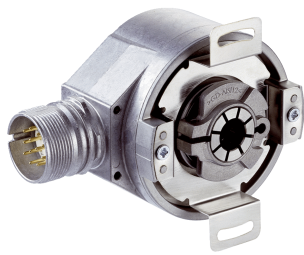

### Ordering information

| Type             | Part no. |
|------------------|----------|
| DFS60B-BHPA10000 | 1036771  |

Other models and accessories → [www.sick.com/DFS60](http://www.sick.com/DFS60)

Illustration may differ



### Detailed technical data

#### Performance

|   |                              |
|---|------------------------------|
| <b>Pulses per revolution</b>                                  | 10,000                       |
| <b>Measuring step</b>   | 90° electronically/ppr       |
| <b>Measuring step deviation at non binary number of lines</b> | ± 0.01°                      |
| <b>Error limits</b>   | ± 0.05°                      |
| <b>Initialization time</b>                                    | 32 ms <sup>1)</sup><br>30 ms |

<sup>1)</sup> With mechanical zero pulse width.

#### Electrical data

|  |   |
|--|---|
| <b>Electrical interface</b>                    | 4.5 V ... 32 V, TTL/HTL programmable, Factory setting: output level TTL |
| <b>Connection type</b>                         | Male connector, M23, 12-pin, radial                                     |
| <b>Operating current</b>                       | 40 mA   |
| <b>Power consumption</b>                       | ≤ 0.7 W (without load)  |
| <b>Load current</b>                            | ≤ 30 mA   |
| <b>Output frequency</b>                        | ≤ 600 kHz   |
| <b>Reference signal, number</b>                | 1   |
| <b>Reference signal, position</b>              | 90°, electric, logically gated with A and B                             |
| <b>Reverse polarity protection</b>             | ✓   |
| <b>Short-circuit protection of the outputs</b> | ✓ <sup>1) 2)</sup>  |
| <b>MTTFd: mean time to dangerous failure</b>   | 300 years (EN ISO 13849-1) <sup>3)</sup>                                |

<sup>1)</sup> Programming TTL with ≥ 5,5 V: short-circuit opposite to another channel or GND permissible for maximum 30 s.

<sup>2)</sup> Programming HTL or TTL with < 5,5 V: short-circuit opposite to another channel, US or GND permissible for maximum 30 s.

<sup>3)</sup> This product is a standard product and does not constitute a safety component as defined in the Machinery Directive. Calculation based on nominal load of components, average ambient temperature 40 °C, frequency of use 8760 h/a. All electronic failures are considered hazardous. For more information, see document no. 8015532.

## Mechanical data

|  |   |
|--|---|
| <b>Mechanical version</b>                                | Blind hollow shaft                      |
| <b>Shaft diameter</b>                                    | 15 mm                                   |
| <b>Weight</b>  | 0.2 kg                                  |
| <b>Shaft material</b>                                    | Metal                                   |
| <b>Flange material</b>                                   | Aluminum                                |
| <b>Housing material</b>                                  | Aluminum die cast                       |
| <b>Start up torque</b>                                   | 0.8 Ncm (+20 °C)                        |
| <b>Operating torque</b>                                  | 0.6 Ncm (+20 °C)                        |
| <b>Permissible shaft movement, axial static/dynamic</b>  | ± 0.5 mm / ± 0.2 mm                     |
| <b>Permissible shaft movement, radial static/dynamic</b> | ± 0.3 mm / ± 0.1 mm                     |
| <b>Operating speed</b>                                   | ≤ 6,000 min <sup>-1</sup> <sup>1)</sup> |
| <b>Moment of inertia of the rotor</b>                    | 40 gcm <sup>2</sup>                     |
| <b>Bearing lifetime</b>                                  | 3.6 x 10 <sup>10</sup> revolutions      |
| <b>Angular acceleration</b>                              | ≤ 500,000 rad/s <sup>2</sup>            |

<sup>1)</sup> Take into account self-heating of 3.3 K per 1,000 rpm when designing the operating temperature range.

## Ambient data

|                                      |  |
|--------------------------------------|--|
| <b>EMC</b>                           | According to EN 61000-6-2 and EN 61000-6-3   |
| <b>Enclosure rating</b>              | IP67, housing side, connector outlet (according to IEC 60529) <sup>1)</sup><br>IP65, shaft side (according to IEC 60529) |
| <b>Permissible relative humidity</b> | 90 % (condensation of the optical scanning not permitted)  |
| <b>Operating temperature range</b>   | -40 °C ... +100 °C <sup>2)</sup><br>-30 °C ... +100 °C <sup>3)</sup>   |
| <b>Storage temperature range</b>     | -40 °C ... +100 °C, without package  |
| <b>Resistance to shocks</b>          | 70 g, 6 ms (according to EN 60068-2-27)  |
| <b>Resistance to vibration</b>       | 30 g, 10 Hz ... 2,000 Hz (according to EN 60068-2-6)   |

<sup>1)</sup> With mating connector fitted.

<sup>2)</sup> Stationary position of the cable.

<sup>3)</sup> Flexible position of the cable.

## Classifications

|                     |          |
|---------------------|----------|
| <b>ECl@ss 5.0</b>   | 27270501 |
| <b>ECl@ss 5.1.4</b> | 27270501 |
| <b>ECl@ss 6.0</b>   | 27270590 |
| <b>ECl@ss 6.2</b>   | 27270590 |
| <b>ECl@ss 7.0</b>   | 27270501 |
| <b>ECl@ss 8.0</b>   | 27270501 |
| <b>ECl@ss 8.1</b>   | 27270501 |
| <b>ECl@ss 9.0</b>   | 27270501 |
| <b>ETIM 5.0</b>     | EC001486 |
| <b>ETIM 6.0</b>     | EC001486 |

UNSPSC 16.0901

41112113

### Dimensional drawing (Dimensions in mm (inch))

Blind hollow shaft, radial plug connection M12 and M23

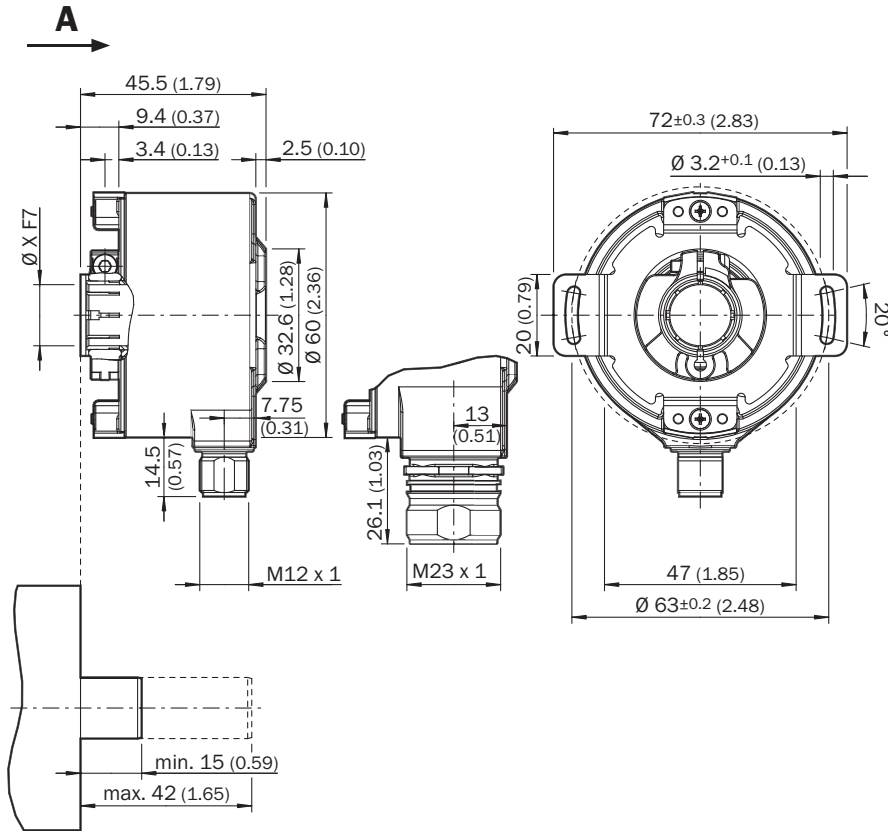

General tolerances according to DIN ISO 2768-mk

| Type<br>Blind hollow shaft | Shaft diameter XF7 | Shaft diameter xj7   |
|----------------------------|--------------------|----------------------|
| DFS60x-BAxxxxxxx           | 6 mm               | Provided by customer |
| DFS60x-BBxxxxxxx           | 8 mm               |                      |
| DFS60x-BCxxxxxxx           | 3/8"               |                      |
| DFS60x-BDxxxxxxx           | 10 mm              |                      |
| DFS60x-BExxxxxxx           | 12 mm              |                      |
| DFS60x-BFxxxxxxx           | 1/2"               |                      |
| DFS60x-BGxxxxxxx           | 14 mm              |                      |
| DFS60x-BHxxxxxxx           | 15 mm              |                      |
| DFS60x-BJxxxxxxx           | 5/8"               |                      |

## PIN assignment

### Cable, 8-wire

View of M12 male device connector on encoder



View of M23 male device connector on encoder

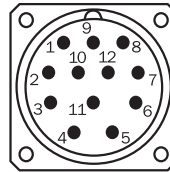

| PIN, 8-pin, M12 male connector | PIN, 12-pin, M23 male connector | Color of the wires for encoders with cable outlet | TTL/HTL signal      | Sin/cos 1.0 V <sub>SS</sub> | Explanation  |
|--------------------------------|---------------------------------|---|---------------------|-----------------------------|--|
| 1                              | 6                               | Brown   | $\bar{A}$           | COS-                        | Signal wire  |
| 2                              | 5                               | White   | A                   | COS+                        | Signal wire  |
| 3                              | 1                               | Black   | $\bar{B}$           | SIN-                        | Signal wire  |
| 4                              | 8                               | Pink  | B                   | SIN+                        | Signal wire  |
| 5                              | 4                               | Yellow  | $\bar{Z}$           | $\bar{Z}$                   | Signal wire  |
| 6                              | 3                               | Violet  | Z                   | Z                           | Signal wire  |
| 7                              | 10                              | Blue  | GND                 | GND                         | Ground connection of the encoder   |
| 8                              | 12                              | Red   | +U <sub>s</sub>     | +U <sub>s</sub>             | Supply voltage (volt-free to housing)  |
| -                              | 9                               | -   | n.c.                | n.c.                        | Not assigned   |
| -                              | 2                               | -   | n.c.                | n.c.                        | Not assigned   |
| -                              | 11                              | -   | n.c.                | n.c.                        | Not assigned   |
| -                              | 7 <sup>1)</sup>                 | -   | 0-SET <sup>1)</sup> | n.c.                        | Set zero pulse <sup>1)</sup>   |
| Screen                         | Screen                          | Screen  | Screen              | Screen                      | Screen connected to housing on encoder side.<br>Connected to ground on control side. |

<sup>1)</sup> For electrical interfaces only: M, U, V, W with 0-SET function on PIN 7 on M23 male connector. The 0-SET input is used to set the zero pulse on the current shaft position. If the 0-SET input is connected to U<sub>s</sub> for longer than 250 ms after it had previously been unassigned for at least 1,000 ms or had been connected to the GND, the current position of the shaft is assigned to the zero pulse signal "Z".

## Maximum revolution range

Maximum revolution range

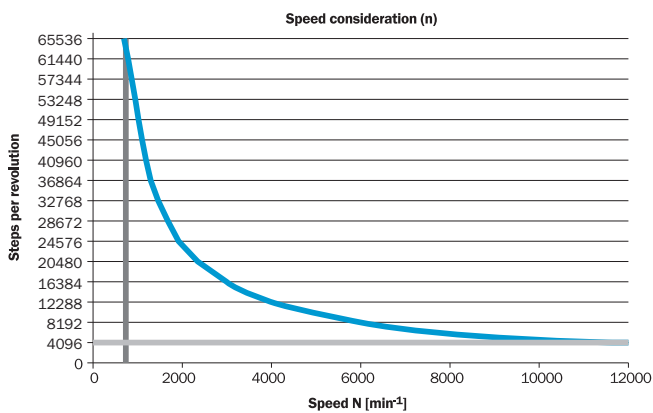

### Diagrams

Electrical zero pulse width can be configured to 90°, 180°, or 270°. Width of the zero pulse in relation to a pulse period.

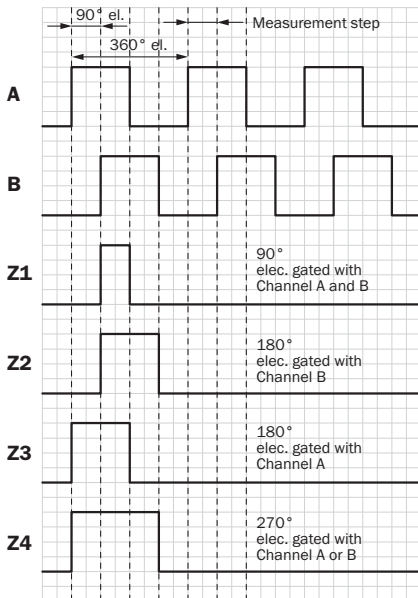

Cw with view on the encoder shaft in direction "A", compare dimensional drawing.

Mechanical zero pulse width 1° to 359° programmable. Width of the zero pulse in relation to a mechanical revolution of the shaft.

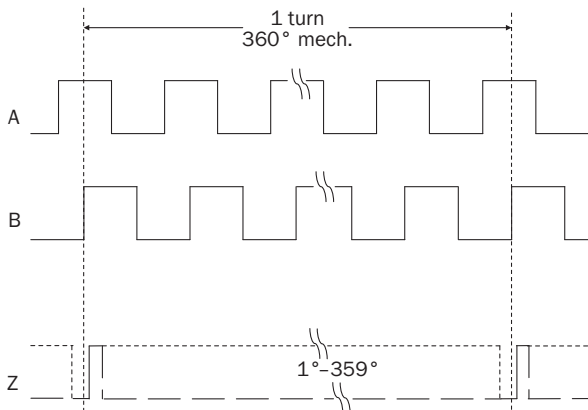

### Recommended accessories

Other models and accessories → [www.sick.com/DFS60](http://www.sick.com/DFS60)

|   | Brief description        | Type        | Part no. |
|---|--------------------------|-------------|----------|
| Flanges   |                          |             |          |
|  | Standard stator coupling | BEF-DS00XFX | 2056812  |

|   | Brief description  | Type             | Part no. |
|---|--|------------------|----------|
| <b>Other mounting accessories</b>   |  |                  |          |
|    | Clamping ring for metal hollow shaft, metal  | BEF-KR-M         | 2064709  |
| <b>Plug connectors and cables</b>   |  |                  |          |
|    | Head A: female connector, M23, 12-pin, straight<br>Head B: Flying leads<br>Cable: Incremental, PUR, shielded, 2 m                        | DOL-2312-G02MLA3 | 2030682  |
|    | Head A: female connector, M23, 12-pin, straight<br>Head B: Flying leads<br>Cable: Incremental, PUR, shielded, 3 m                        | DOL-2312-G03MMA3 | 2029213  |
|    | Head A: female connector, M23, 12-pin, straight<br>Head B: Flying leads<br>Cable: Incremental, PUR, shielded, 5 m                        | DOL-2312-G05MMA3 | 2029214  |
|    | Head A: female connector, M23, 12-pin, straight<br>Head B: Flying leads<br>Cable: Incremental, PUR, shielded, 7 m                        | DOL-2312-G07MLA3 | 2030685  |
|    | Head A: female connector, M23, 12-pin, straight<br>Head B: Flying leads<br>Cable: Incremental, PUR, shielded, 10 m                       | DOL-2312-G10MLA3 | 2030688  |
|    | Head A: female connector, M23, 12-pin, straight<br>Head B: Flying leads<br>Cable: Incremental, PUR, shielded, 10 m                       | DOL-2312-G10MMA3 | 2029215  |
|   | Head A: female connector, M23, 12-pin, straight<br>Head B: Flying leads<br>Cable: Incremental, PUR, shielded, 15 m                       | DOL-2312-G15MLA3 | 2030692  |
|  | Head A: female connector, M23, 12-pin, straight<br>Head B: Flying leads<br>Cable: Incremental, PUR, shielded, 1.5 m                      | DOL-2312-G1M5MA3 | 2029212  |
|  | Head A: female connector, M23, 12-pin, straight<br>Head B: Flying leads<br>Cable: Incremental, PUR, shielded, 20 m                       | DOL-2312-G20MLA3 | 2030695  |
|  | Head A: female connector, M23, 12-pin, straight<br>Head B: Flying leads<br>Cable: Incremental, PUR, shielded, 20 m                       | DOL-2312-G20MMA3 | 2029216  |
|  | Head A: female connector, M23, 12-pin, straight<br>Head B: Flying leads<br>Cable: Incremental, PUR, shielded, 25 m                       | DOL-2312-G25MLA3 | 2030699  |
|  | Head A: female connector, M23, 12-pin, straight<br>Head B: Flying leads<br>Cable: Incremental, PUR, shielded, 25 m                       | DOL-2312-G30MLA3 | 2030702  |
|  | Head A: female connector, M23, 12-pin, straight<br>Head B: Flying leads<br>Cable: Incremental, PUR, shielded, 30 m                       | DOL-2312-G30MMA3 | 2029217  |
|  | Head A: female connector, M23, 12-pin, straight<br>Head B: male connector, D-Sub, 9-pin, straight<br>Cable: Incremental, shielded, 0.5 m | DSL-3D08-G0M5AC3 | 2046580  |
|  | Head A: female connector, M23, 12-pin, straight<br>Head B: -<br>Cable: HIPERFACE®, SSI, Incremental, shielded                            | DOS-2312-G02     | 2077057  |
|  | Head A: female connector, M23, 12-pin, angled<br>Head B: -<br>Cable: HIPERFACE®, SSI, Incremental, shielded                              | DOS-2312-W01     | 2072580  |
| <b>Programming and configuration tools</b>  |  |                  |          |
|  | USB programming unit, for programmable SICK encoders AFS60, AFM60, DFS60, VFS60, DFV60 and wire draw encoders with programmable encoders | PGT-08-S         | 1036616  |

|   | <b>Brief description</b>  | <b>Type</b> | <b>Part no.</b> |
|---|---|-------------|-----------------|
|  | Programming unit display for programmable SICK DFS60, DFV60, AFS/AFM60, AHS/AHM36 encoders, and wire draw encoder with DFS60, AFS/AFM60 and AHS/AHM36. Compact dimensions, low weight, and intuitive operation. | PGT-10-Pro  | 1072254         |



## SICK AT A GLANCE

SICK is one of the leading manufacturers of intelligent sensors and sensor solutions for industrial applications. A unique range of products and services creates the perfect basis for controlling processes securely and efficiently, protecting individuals from accidents and preventing damage to the environment.

We have extensive experience in a wide range of industries and understand their processes and requirements. With intelligent sensors, we can deliver exactly what our customers need. In application centers in Europe, Asia and North America, system solutions are tested and optimized in accordance with customer specifications. All this makes us a reliable supplier and development partner.

Comprehensive services complete our offering: SICK LifeTime Services provide support throughout the machine life cycle and ensure safety and productivity.

For us, that is “Sensor Intelligence.”

## WORLDWIDE PRESENCE:

Contacts and other locations –[www.sick.com](http://www.sick.com)