

NOTES

MATERIAL: -DIECAST ALUMINUM ALLOY.
-FOUR 6-32 Phillips screws

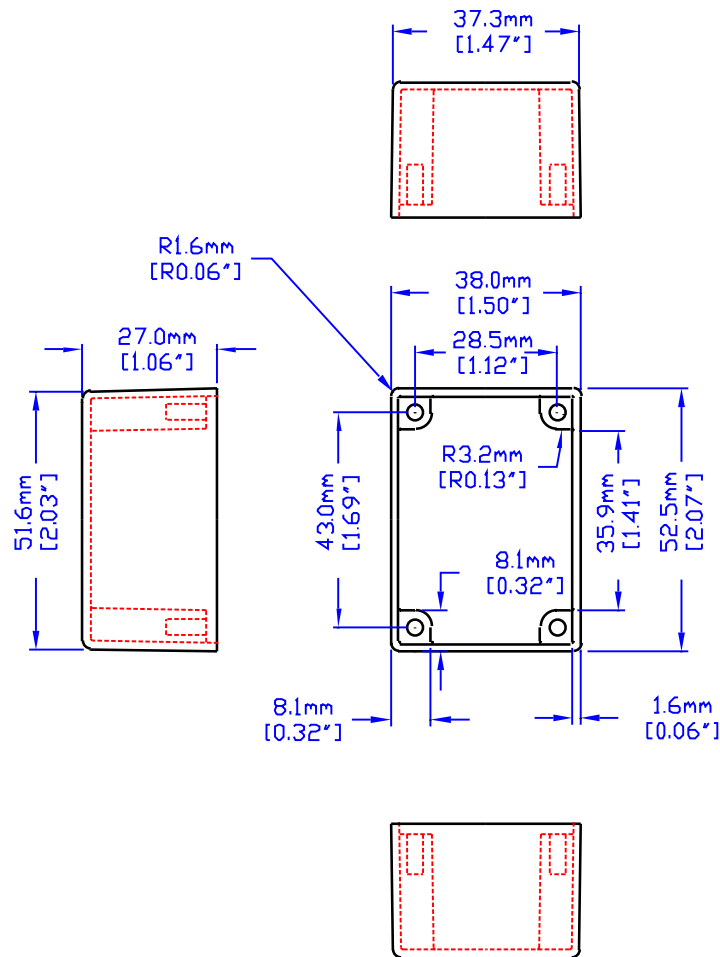

VIEW OF BOX (LID REMOVED)

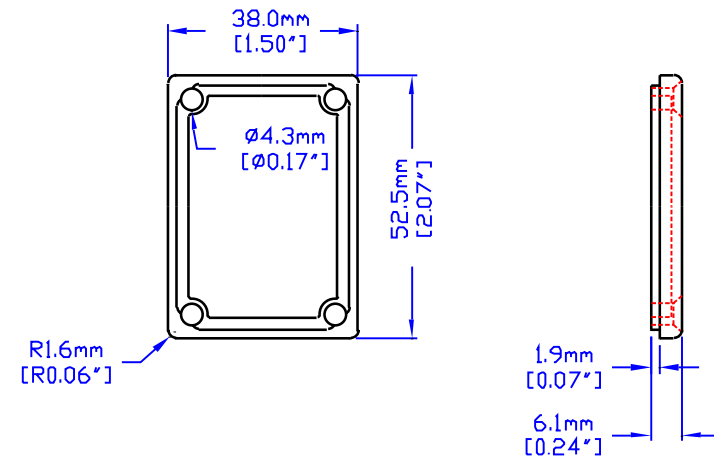

VIEW INSIDE LID



HAMMOND MANUFACTURING

11451PSLA

CANADA - PH (519) 886 7170 - FAX (519) 886 8311
U.S.A. - PH (716) 631 5700 - FAX (716) 631 1156

Shallow Lid - Thin Wall



KEY FEATURES

- Rugged, lightweight, diecast aluminum alloy (robust - yet easy to machine), electronic instrument enclosure.
- Aluminum alloy to BS1490, LM2M.
- Two piece "lap joint" construction provides protection against dust accumulation and splashing water. Also provides for high EMC screening.
- Lids are close fitting and are retained by 4 - M3.5 x 6 tapite screws into countersunk lid holes. Screws accept POZIDRIV No. 2 screwdriver.
- Enclosures are supplied unpainted. Will accept most finishes with minimum preparation.
- Designed to meet IP54.



Hammond Electronics Limited
1 Onslow Close
Kingsland Business Park
Basingstoke, Hampshire RG24 8QL, UK
Tel: 01256 812812 Fax: 01256 332249

www.hammondmfg.com

Shallow Lid - Thin Wall

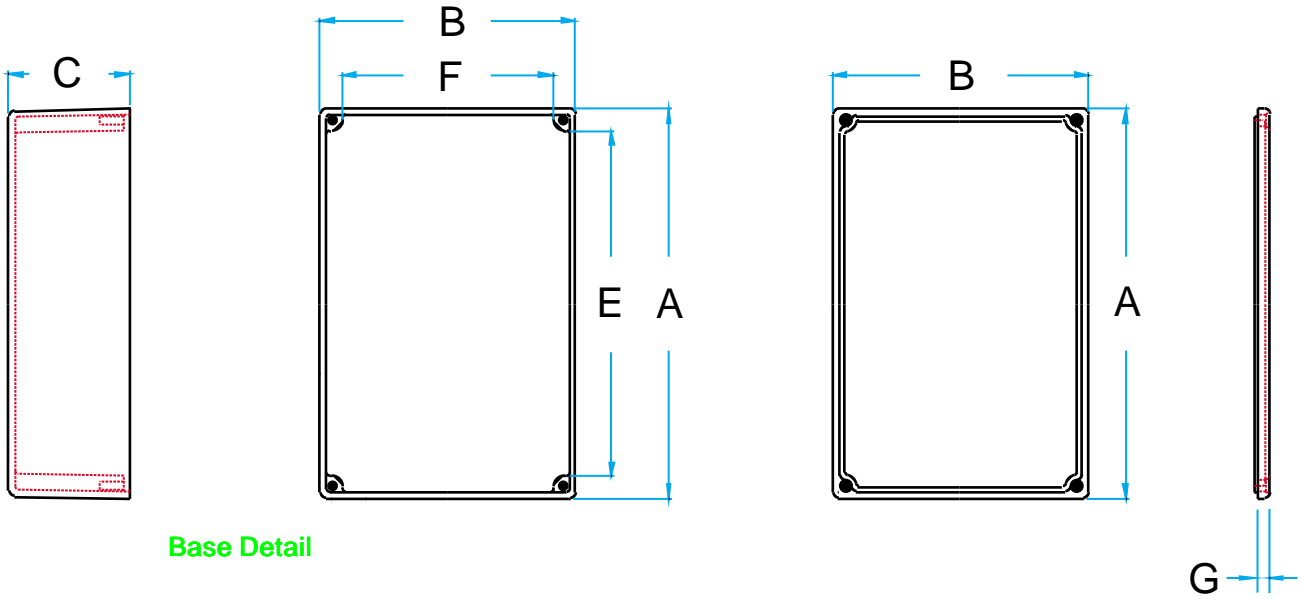

Base Detail

Lid Detail

- Notes:**
- Assembled height = dimension "C" + 4.0 mm
 - Wall & lid thickness is roughly 2 mm and varies with draft due to part being cast.
 - For detailed drawings, CAD files or technical bulletins visit our website at: www.hammondmfg.com

Part Number	Units	Dimensions					Lid Height
		A	B	C (No Lid)	E	F	
10758PSLA	mm	145	95	45	128.5	78.5	4
11130PSLA	mm	125	125	75	108.5	108.5	4
11451PSLA	mm	52.5	38	27	35.9	21.8	4
26357PSLA	mm	188	120	78	170.4	103	4
26827PSLA	mm	188	120	53	170.4	103	4
26908PSLA	mm	120	95	53	103.5	78.5	4
27134PSLA	mm	111	60	27	94.4	43.7	4
27969PSLA	mm	92	38	27	75.7	21.7	4
29830PSLA	mm	120	95	30	103.5	78.5	4

For detailed drawings, CAD files or technical bulletins visit our website at: www.hammondmfg.com

