



Price Index



10 Widths  
6 Bending Radii



Product Range

Inner Widths (Bi) in mm:	40, 50, 75, 88, 100, 125, 135, 150, 175, 200
Bending Radii (R) in mm:	100, 125, 150, 175, 200, 250
Pitch:	46 mm/link = 22 links/m (1012 mm)

Unsupported length

- FL<sub>B</sub> = unsupported with permitted sag
- FL<sub>G</sub> = unsupported with straight upper run

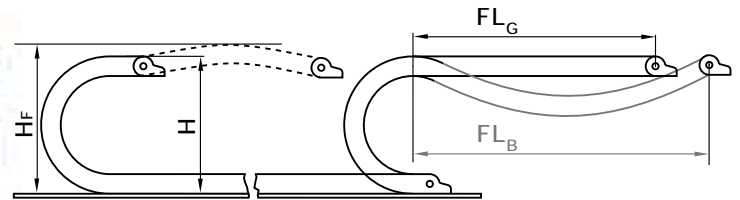

Interior separation possible

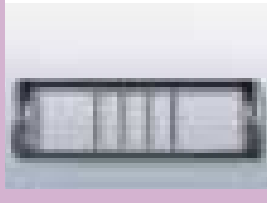

4 options for mounting brackets



Quickflange available upon request

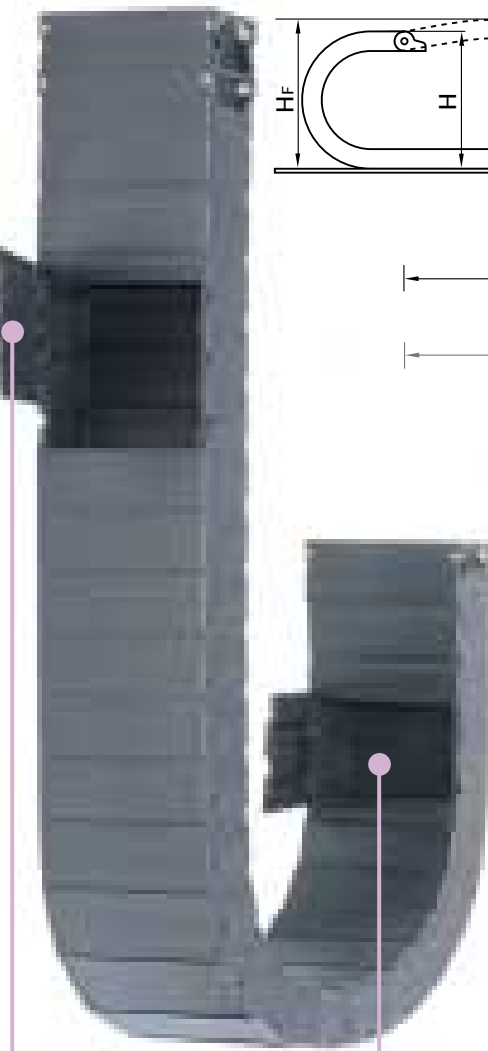
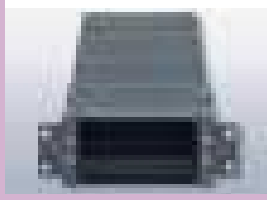

Snap-open lids along the inner or outer radius

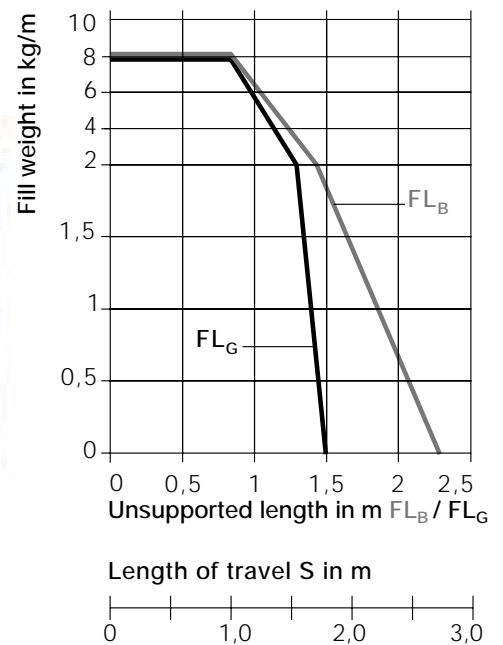

When to use the Series R157/R158:

- If snap-open accessibility along both radii
- If a low-cost, lightweight Energy Tube for many types of applications required
- If flush mounting is required
- Chip-repellent features are required



When not to use them:

- If snap-open accessibility along both radii
  - ▶ System E4/100, Series R770, Page 7.30
- If particularly quiet operation is required
  - ▶ Series R, Series R58, Page 6.38

Series R157 - Energy Tube (hinged, open on both sides of the inner radius)

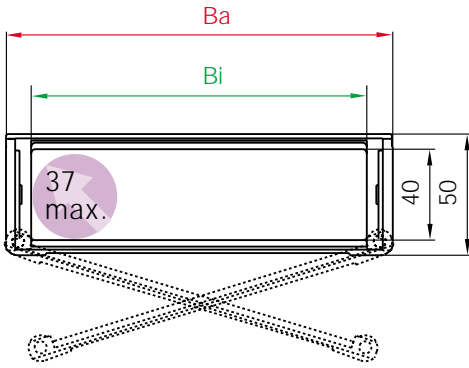

Order Example



157.040.150.0

Standard color  
0 = Black

● Other colors  
▶ Design,  
Page 1.62

Part No.		Bi	Ba	Bending Radii
157.040*	Radius	040	056	100 125 150 175
157.050	Radius	050	066	200 250
157.075	Radius	075	091	
157.088	Radius	088	104	
157.090**	Radius	088	104	
157.100	Radius	100	116	
157.125	Radius	125	141	
157.135	Radius	135	150	
157.150	Radius	150	166	These bending radii can be
157.175	Radius	175	191	combined with every tube
157.200	Radius	200	216	width!

\* Lid removable only, not hinged

\*\* Same dimensions as 157.088 - less recent design, no hinged option

Supplement part no. with required radius for example 157.100.100.0

Series R158 - Energy Tube (hinged, snap-open on both sides of the outer radius)

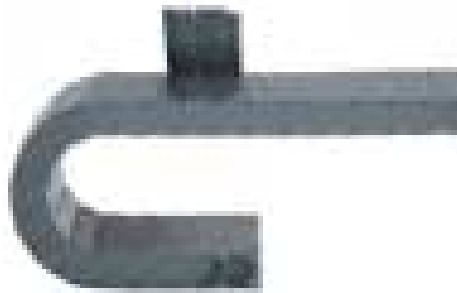
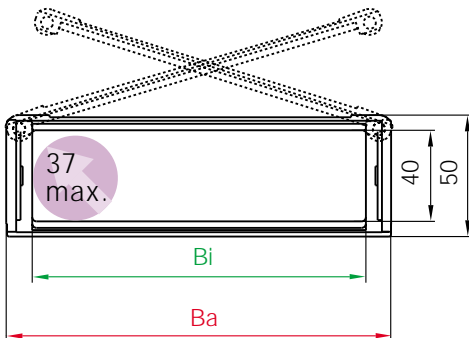

Part No.		Bi	Ba	Bending Radii
158.040*	Radius	040	056	100 125 150 175
158.050	Radius	050	066	200 250
158.075***	Radius	075	091	
158.088	Radius	088	104	
158.090**	Radius	088	104	
158.100	Radius	100	116	
158.125***	Radius	125	141	
158.135	Radius	135	150	
158.150	Radius	150	166	These bending radii can be
158.175***	Radius	175	191	combined with every tube
158.200	Radius	200	216	width!

\* Lid removable only, not hinged

\*\* Same dimensions as 158.088 - less recent design, no hinged option

\*\*\* Delivery time available upon request

Supplement part no. with required radius for example 158.100.100.0



upon request

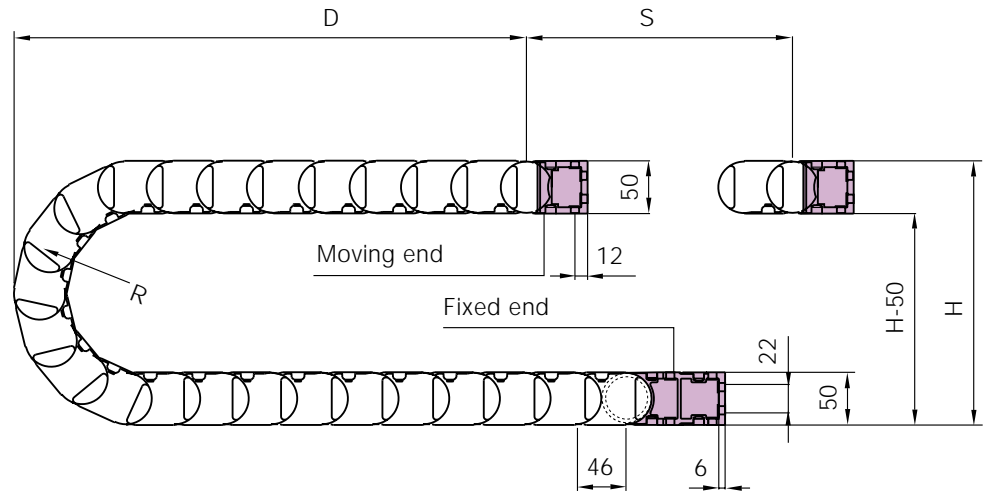

Pitch: = 46 mm per link

Links per m: = 22

Tube length: =  $\frac{S}{2} + K$



R	100	125	150	175	200	250
H*	250	300	350	400	450	550
D	175	200	225	250	275	325
K	410	485	565	645	725	880

\*The required clearance height is HF = H + 40 mm (with 1kg/m fill weight)

Please consult igus® if space is particularly restricted.

### Vertical Separators

Vertical separators are used to divide the interior of the Energy Tube. They most commonly perform the tasks of distributing the tube's fill weight evenly and keeping dissimilar conduits apart. Separators are removable and adjustable for a variety of chamber widths.

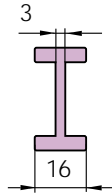
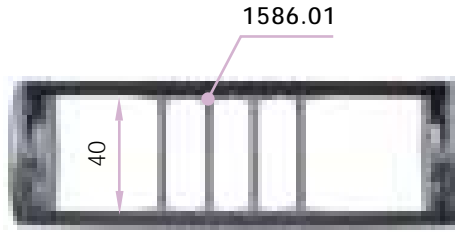

Separators

Unassembled Part No. 1585.01

Assembled Part No. 1586.01

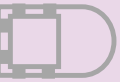
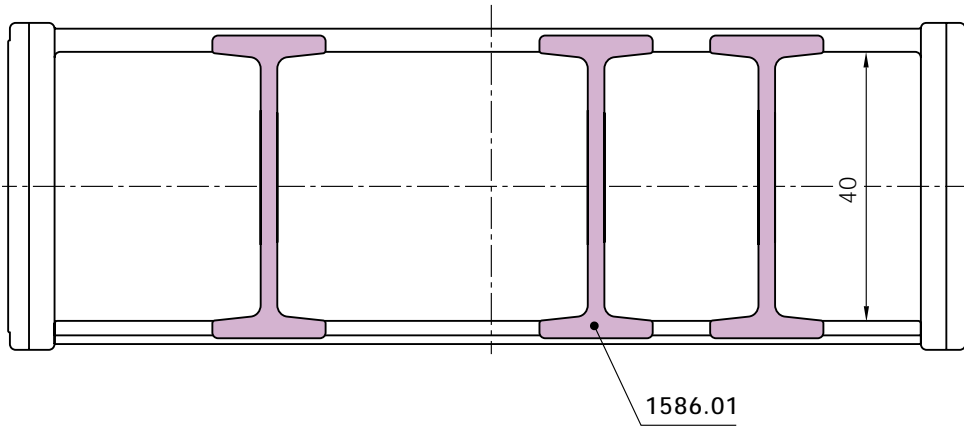

upon request

4 options for all applications

**Option 1: Extended, Pivoting**

15800/15801...1  
Moving end

- ! Standard
- + Extended, pivoting
- + Easy to install
- + Universal use
- + Locked connection to Energy Tube
- + Long travels with lowered mounting height possible
- + Corrosion-resistant
- Vertical hanging/standing, unsupported

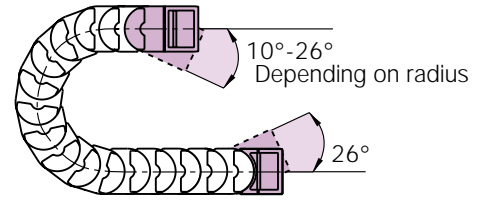

15800/15801...2  
Fixed end

**Option 1: polymer pivoting**

- Standard
- Extended

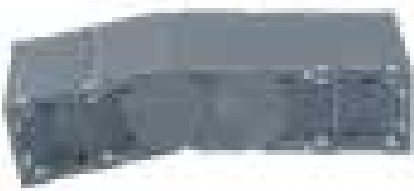

**Option 2: polymer locking**

- Extended
- For example: vertically installed tubes



**Option 3: polymer pivoting**

- Abbreviated



**Option 4: Polymer locking**

- Abbreviated
- For example: vertically installed tubes

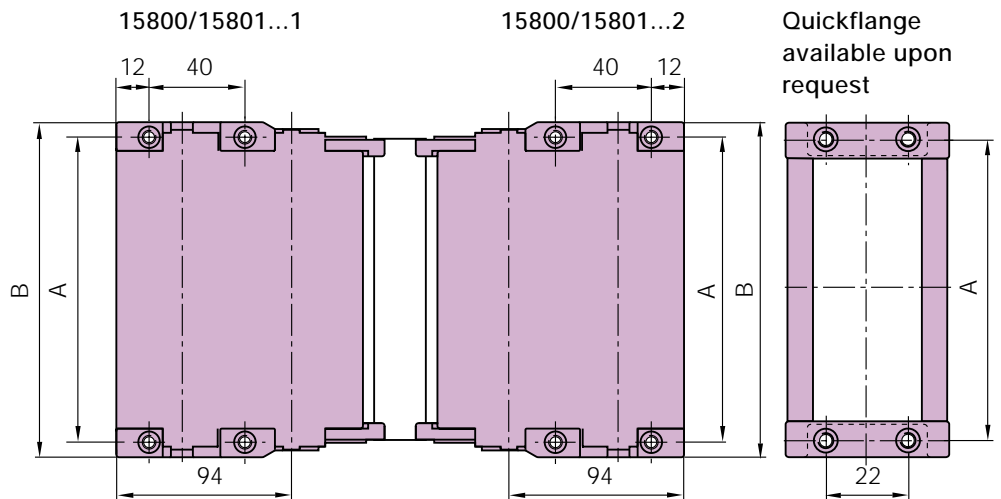

Tube Type	Part No. Full Set	Dimension A in mm	Dimension B in mm
157/158.040	15801.040.12	50	61
157/158.050	15800.050.12	60	71
157/158.075	15800.075.12	85	96
157/158.088	15800.090.12	98	109
157/158.090	15801.090.12	98	109
157/158.100	15800.100.12	110	121
157/158.125	15800.125.12	135	146
157/158.135	15800.135.12	145	156
157/158.150	15800.150.12	160	171
157/158.175	15800.175.12	185	196
157/158.200	15800.200.12	210	221

15800/15801...12 = Full set, each part with pin/bore  
 15800/15801...1 = Mounting bracket with bore  
 15800/15801...2 = Mounting bracket with pin

The following parts are required for attachment of the mounting brackets:

- Socket head cap bolt M5\* DIN 912-8.8      8 pieces/set
- Washer 5,3 DIN 125-ST      8 pieces/set
- Hexagon nut M5 DIN 934-8      8 pieces/set

\* The length of the socket head cap bolt is dependent on the thickness of the attachment base.

# Mounting Brackets

## Option 2: Extended, Locking

15800/158051...3  
Moving end

- Extended, locking
- Easy to install
- Flush mounting at both ends of the tube
- Mounting points on all sides
- Corrosion-resistant
- Pivoting at both ends

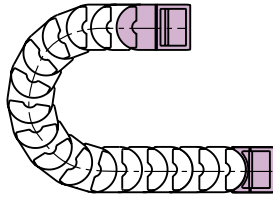

15800/15801...4  
Fixed end

### Option 2: polymer locking

- Extended
- For example: vertically installed tubes

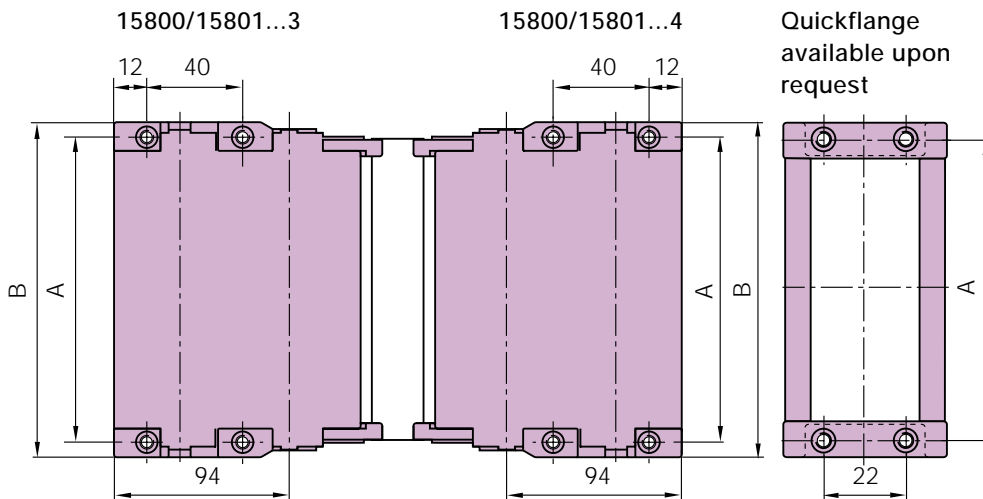

Quickflange  
available upon  
request

Tube Type	Part No. Full Set	Dimension A in mm	Dimension B in mm
157/158.040	15801.040.34	50	61
157/158.050	15800.050.34	60	71
157/158.075	15800.075.34	85	96
157/158.088	15800.090.34	98	109
157/158.090	15801.090.34	98	109
157/158.100	15800.100.34	110	121
157/158.125	15800.125.34	135	146
157/158.135	15800.135.34	145	156
157/158.150	15800.150.34	160	171
157/158.175	15800.175.34	185	196
157/158.200	15800.200.34	210	221

15800/15801...34 = Full set, each part with pin/bore  
 15800/15801...3 = Mounting bracket with bore  
 15800/15801...4 = Mounting bracket with pin

The following parts are required for attachment of the mounting brackets:

- Socket head cap bolt M5\* DIN 912-8.8      8 pieces/set
- Washer 5,3 DIN 125-ST      8 pieces/set
- Hexagon nut M5 DIN 934-8      8 pieces/set

\* The length of the socket head cap bolt is dependent on the thickness of the attachment base.

Phone +49- (0) 22 03 96 49-0  
 Fax +49- (0) 22 03 96 49-222

upon request

Option 3: Abbreviated, Pivoting

1580...1

Moving end

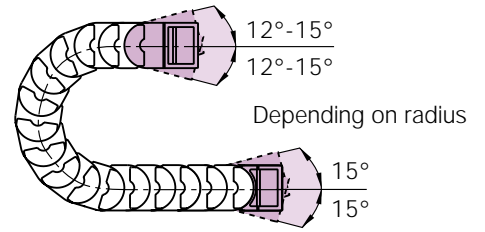

- + Abbreviated, pivoting
- + Universal use
- + Locked connection to Energy Tube
- + Long travels with lowered mounting height possible
- + Corrosion-resistant
- Vertical hanging/standing, unsupported
- Handling

1580...2  
Fixed end

Option 3: polymer pivoting

- Abbreviated



Phone +49- (0) 22 03 96 49-0  
Fax +49- (0) 22 03 96 49-222

igus® GmbH  
51127 Cologne

Internet: <http://www.igus.de>  
email: [info@igus.de](mailto:info@igus.de)

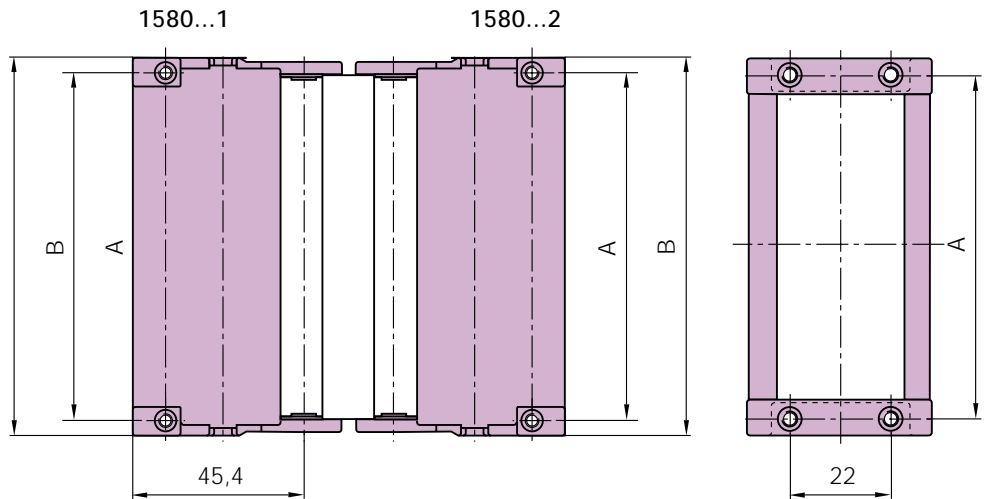

Tube Type	Part No. Full Set	Dimension A in mm	Dimension B in mm
157/158.040	1580.040.12	50	61
157/158.050	1580.050.12	60	71
157/158.075	1580.075.12	85	96
157/158.088	1580.090.12	98	109
157/158.090	1580.090.12	98	109
157/158.100	1580.100.12	110	121
157/158.125	1580.125.12	135	146
157/158.135	1580.135.12	145	156
157/158.150	1580.150.12	160	171
157/158.175	1580.175.12	185	196
157/158.200	1580.200.12	210	221

1580...12 = Full set, each part with pin/bore  
1580...1 = Mounting bracket with bore  
1580...2 = Mounting bracket with pin

The following parts are required for attachment of the mounting brackets:

- Socket head cap bolt M5\* DIN 912-8.8      4/8 pieces/set
- Washer 5,3 DIN 125-ST      8/16 pieces/set
- Hexagon nut M5 DIN 934-8      4/8 pieces/set

\* The length of the socket head cap bolt is dependent on the thickness of the attachment base.

# Mounting Brackets

## Option 4: Abbreviated, Locking

- Abbreviated, locking
- Flush mounting at both ends of the tube
- Flush mounting, turned 90° at fixed end option
- Corrosion-resistant
- Highly space-restricted
- Handling

1585...1

Moving end

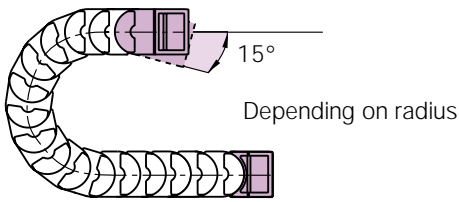

1585...2

Fixed end

### Option 4: polymer locking

- Abbreviated
- For example: vertically installed tubes

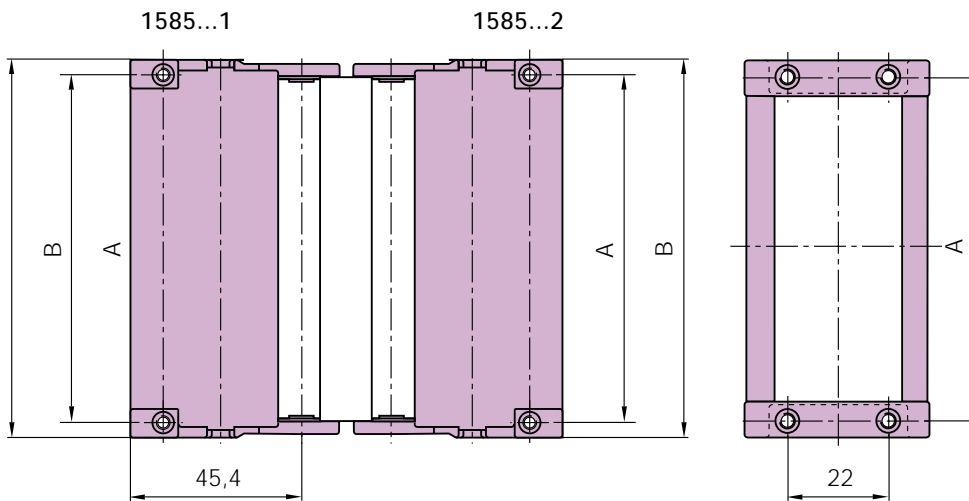

Tube Type	Part No. Full Set	Dimension A in mm	Dimension B in mm
157/158.040	1585.040.12	50	61
157/158.050	1585.050.12	60	71
157/158.075	1585.075.12	85	96
157/158.088	1585.090.12	98	109
157/158.090	1585.090.12	98	109
157/158.100	1585.100.12	110	121
157/158.125	1585.125.12	135	146
157/158.135	1585.135.12	145	156
157/158.150	1585.150.12	160	171
157/158.175	1585.175.12	185	196
157/158.200	1585.200.12	210	221

1585...12 = Full set, each part with pin/bore

1585...1 = Mounting bracket with bore

1585...2 = Mounting bracket with pin

The following parts are required for attachment of the mounting brackets:

- Socket head cap bolt M5\* DIN 912-8.8      4/8 pieces/set
- Washer 5,3 DIN 125-ST      8/16 pieces/set
- Hexagon nut M5 DIN 934-8      4/8 pieces/set

\* The length of the socket head cap bolt is dependent on the thickness of the attachment base.

Phone +49- (0) 22 03 96 49-0  
Fax +49- (0) 22 03 96 49-222

upon request



157.088...

Order Example

1. Tube selection:

157.088.100.0  
 Color black  
 Radius  
 Width  
 Tube Type

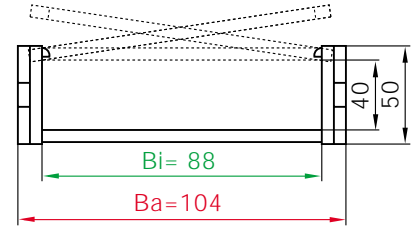

2. Mounting brackets:

15800.088.12  
 Full set, pivoting  
 Tube width

3. Interior separation:



2 vertical separators (Part No.1585.01) or  
 assembled every other tube link, (Part No. 1586.01)

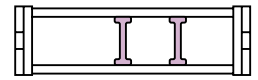

Alternatively Interior separation configuration according to design layout possible.

For 5 m tube, color black,  
 with pivoting mounting brackets:  
 5 m 157.088.100.0 and 15800.088.12  
 110 links (22 links/m)

4. Other technical data on guide troughs upon request

Technical Data

Tube Type	Weight Per Link (kg)	Weight Per Meter (kg)
157/158.040	≈ 0,055	≈ 1,21
157/158.050	≈ 0,059	≈ 1,30
157/158.075	≈ 0,068	≈ 1,50
157/158.088	≈ 0,071	≈ 1,57
157/158.090	≈ 0,074	≈ 1,63
157/158.100	≈ 0,078	≈ 1,71
157/158.125	≈ 0,087	≈ 1,92
157/158.135	≈ 0,095	≈ 2,10
157/158.150	≈ 0,097	≈ 2,13
157/158.175	≈ 0,106	≈ 2,34
157/158.200	≈ 0,120	≈ 2,55



The following applies to all series listed here:

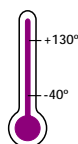

Material		igumid G
Permitted temperature	°C	-40/+130
Gliding speed (maximum)	m/s	1,5
Unsupported v (maximum)	m/s	10
Flammability class		VDE 0304 IIC UL94 1H

- Details of material properties,
- ▶ Design, Page 1.61