



PD70100/PD70200

IEEE® 802.3af/at PD Front End IC

Product Overview

The PD70100 and PD70200 devices are part of Microchip's series of Power over Ethernet (PoE) Powered Device (PD) chips. The PD70100 and PD70200 devices transmit integrated power and analog data in a single 12-pin package. They are used in Powered Devices (PDs), thus enabling next generation network devices to share power and data over the same cable.

Microchip's PD family offers a solution to any PD application compliant with IEEE® 802.3af and IEEE 802.3at standards and 4-pairs extra power applications. The IC family's components can be used in both indoor and outdoor applications.

The device family meets all PD-side-standards such as:

- Detection
- Classification
- Integrated isolation switch with inrush current limiter, and over-current protection
- Two-events classification recognition and AT flag generation (PD70200 only)

In addition, the devices have a discharge mechanism for a DC/DC input capacitor, ensuring quick redetection capability in case the RJ-45 plug is disconnected and reconnected within a short time span.

PD70200 IC design specifically supports IEEE 802.3at standard, including two events classification detection that enables the PD to distinguish whether the connected power source equipment (PSE) is IEEE 802.3at or IEEE 802.3af based.

The PD70200 IC is designed to support 4-pair applications for PDs that require higher power.

Features

- Designed to support IEEE 802.3af and IEEE 802.3at standards
- PD detection and programmable classification signature
- Two-events classification flag
- Signature resistor disconnection after detection
- Integrated 0.6 Ω isolating switch and inrush current limiter
- 4-pairs support with a single PD70200 IC for up to 48 W
- 4-pairs support with two PD70200 ICs for up to 96 W
- Less than 10 μ A offset current during detection
- Single DC voltage input (37 V – 57 V)
- Wide operating temperature range: -40 °C to 85 °C
- On-chip thermal protection
- 12-pin 3 mm × 4 mm package
- RoHS compliant
- MSL3

Table 1. Microchip Powered Device Products Offerings

Part	Type	Package	IEEE 802.3af	IEEE 802.3at	HDBaseT (PoH)	UPoE
PD70100	Front End	3 mm × 4 mm 12L DFN	x	—	—	—
PD70101	Front End + PWM	5 mm × 5 mm 32L QFN	x	—	—	—
PD70200	Front End	3 mm × 4 mm 12L DFN	x	x	—	—
PD70201	Front End + PWM	5 mm × 5 mm 32L QFN	x	x	—	—
PD70210	Front End	4 mm × 5 mm 16L DFN	x	x	x	x
PD70210A	Front End	4 mm × 5 mm 16L DFN	x	x	x	x
PD70210AL	Front End	5 mm × 7 mm 38L QFN	x	x	x	x
PD70211	Front End + PWM	6 mm × 6 mm 36L QFN	x	x	x	x
PD70224	Ideal Diode Bridge	6 mm × 8 mm 40L QFN	x	x	x	x

Applications

- Power over Ethernet Powered Devices
- IEEE 802.3af/at 10/100/1000 BASE-T
- 4-pair extra power applications
- Indoor and outdoor applications

The following illustration shows a basic block diagram using PD70100 or PD70200.

Figure 1. Basic PD Block Diagram

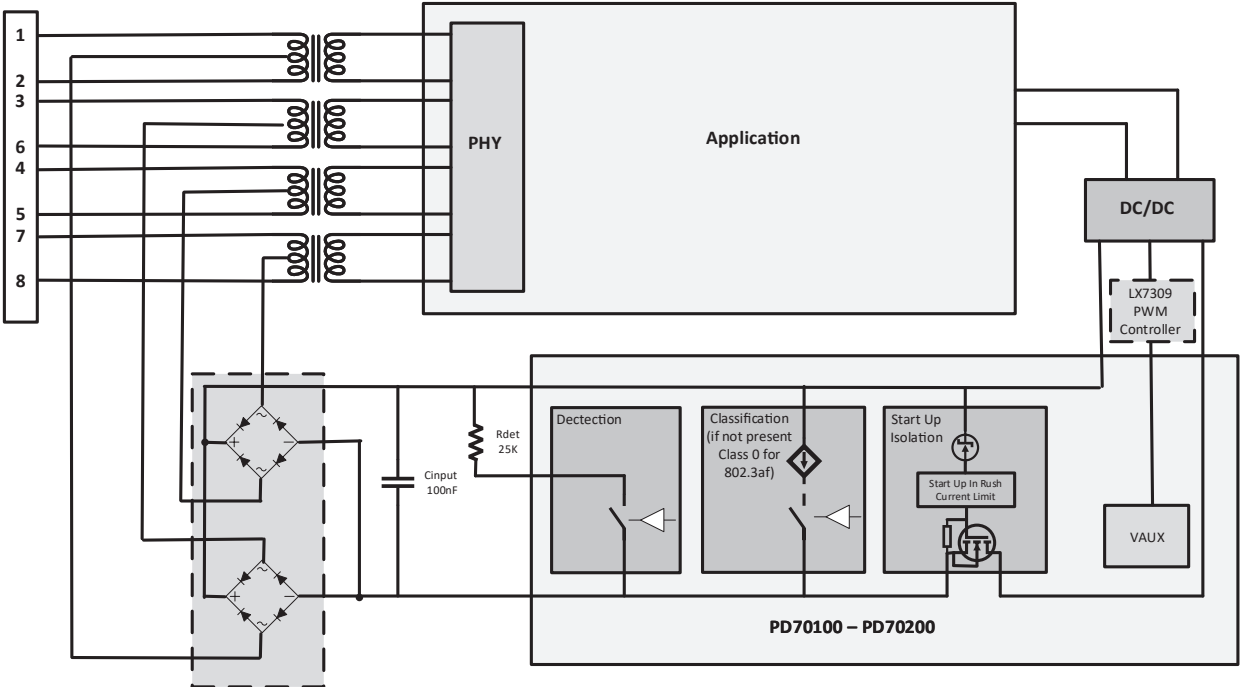

Microchip offers complete reference design packages and Evaluation Boards (EVBs). For access to these design packages, device datasheets, or application notes, consult your local Microchip Client Engagement Manager or visit our website at www.microchip.com/poe. For technical support, consult your local Embedded Solutions Engineers or go to www.microchip.com/support. For help in designing the DC/DC portion of your circuit, please try our MPLAB Analog Designer (MAD) tool at www.microchip.com/mad-poe.

Table of Contents

Product Overview.....	1
Features.....	1
Applications.....	2
1. Functional Descriptions.....	5
1.1. Detail Description.....	6
2. Electrical Specifications.....	9
2.1. Absolute Maximum Ratings.....	9
2.2. Typical Electrical Performance.....	9
2.3. Pin Description.....	13
3. Package Specifications.....	15
3.1. Package Outline Drawing.....	15
3.2. Thermal Specifications.....	16
3.3. Recommended PCB Layout.....	17
4. Ordering Information.....	21
5. References.....	22
6. Revision History.....	23
The Microchip Website.....	24
Product Change Notification Service.....	24
Customer Support.....	24
Microchip Devices Code Protection Feature.....	24
Legal Notice.....	25
Trademarks.....	25
Quality Management System.....	26
Worldwide Sales and Service.....	27

1. Functional Descriptions

The following illustration shows the functional blocks of the PD70100.

Figure 1-1. PD70100 Functional Block Diagram

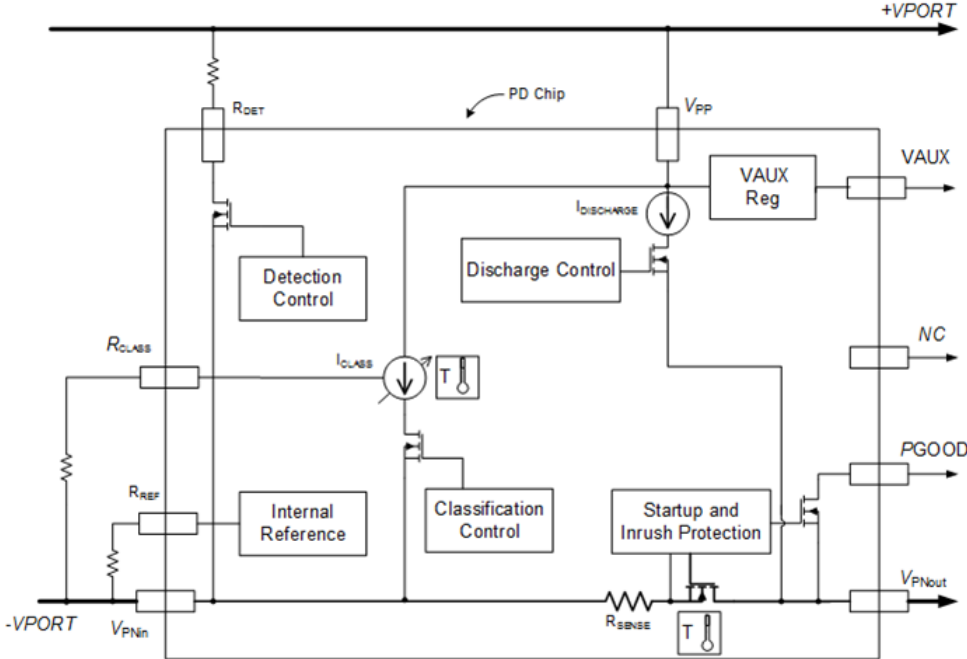

The following illustration shows the functional blocks of the PD70200.

Figure 1-2. PD70200 Functional Block Diagram

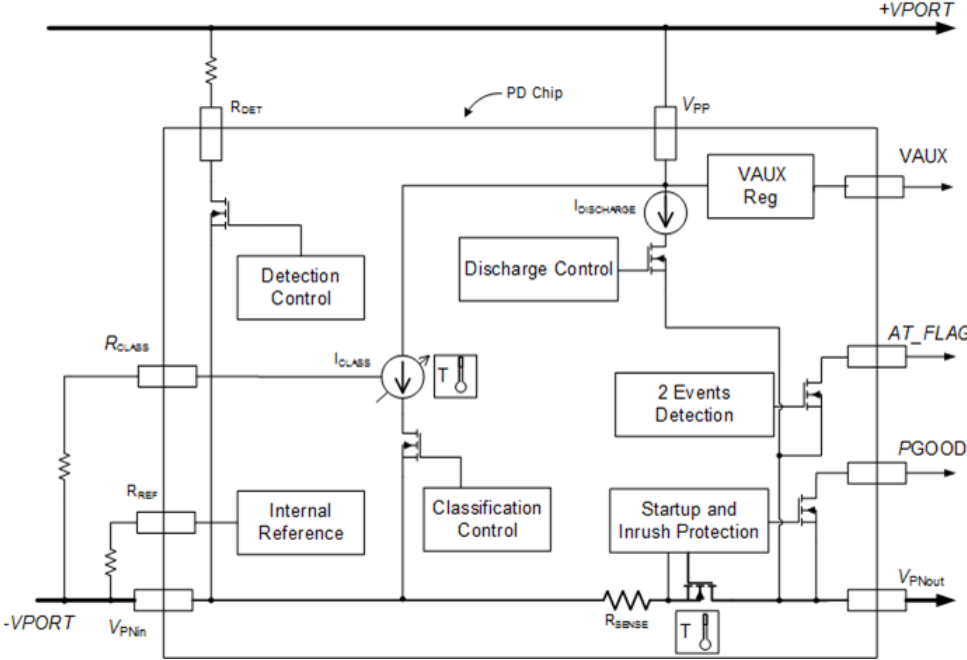

1.1 Detail Description

PD70100/PD70200 IC provides IEEE 802.3af/at compliant PD Front-End functions including Detection, Physical Layer Classification, Two-Events Classification (PD70200 only), Auxiliary Voltage Output, Power Good, Soft Start Current Limiting, Over-Current Protection, and Bulk Capacitor Discharge.

1.1.1 Detection

IEEE 802.3af/at compliant detection is provided by a 24.9 K Ω resistor connected between V_{PP} and R_{DET} pin. R_{DET} pin is connected to VPN_{IN} via an open drain MOSFET with a maximum specified $R_{DS_{ON}}$ of 50 Ω . Internal logic monitors V_{PP} to VPN_{IN} and connects the R_{DET} pin to VPN_{IN} when the rising V_{PP} to VPN_{IN} voltage is between 2.5 V and 10.1 V. When rising V_{PP} to VPN_{IN} voltage exceeds 10.1 V, the MOSFET is switched off. Once above 10.1 V, falling V_{PP} to VPN_{IN} voltage between 2.45 V and 4.85 V will reconnect R_{DET} pin to VPN_{IN} .

1.1.2 Physical Layer Classification

Physical Layer (hardware) Classification per IEEE 802.3af/at is generated via a regulated reference voltage of 1.2 V, switched onto the R_{CLASS} pin. Internal logic monitors the V_{PP} to VPN_{IN} voltage and connects the 1.2 V reference to R_{CLASS} pin at a rising V_{PP} to VPN_{IN} voltage threshold between 11.1 V and 13.5 V. Once V_{PP} to VPN_{IN} has exceeded the rising threshold, there is a 1 V minimum hysteresis between the V_{PP} rising (turn-on) threshold and the V_{PP} falling (turn-off) threshold.

The 1.2 V reference stays connected to the R_{CLASS} pin until the V_{PP} to VPN_{IN} rising voltage exceeds the upper turn-off threshold of 20.9 V to 23.9 V. The 1.2 V reference voltage is disconnected from the R_{CLASS} pin at V_{PP} to VPN_{IN} voltages above the upper threshold.

Classification current signature is provided via a resistor connected between R_{CLASS} pin and VPN_{IN} . The classification current is therefore the current drawn by the PD70100/PD70200 IC during the classification phase, and is simply the 1.2 V reference voltage divided by the R_{CLASS} resistor value. The maximum current available at the R_{CLASS} pin is current limited to 55 mA (typical).

1.1.3 Two-Events Detection and AT Flag

The PD70200 IC provides IEEE 802.3at Type 2 compliant detection of the “Two Events Classification Signature”, and generation of the AT flag. This feature is available on the PD70200 IC only.

Simply put, the “Two Events Classification Signature” is a means by which an IEEE 802.3at Type 2 Power Source can inform a compliant Power Device (PD) that it is AT Type 2 compliant, and as such is capable of providing AT Type 2 power levels.

The Power Source communicates with a Type 2 compliant signature by toggling the V_{PP} to VPN_{IN} voltage twice (2 “events”) during the Physical Layer Classification phase. The V_{PP} to VPN_{IN} voltage is toggled from the Physical Layer Classification’s voltage level (13.5 V to 20.9 V) down to a voltage “Mark” level. Voltage “Mark” level is specified as a V_{PP} to VPN_{IN} voltage of 4.9 V to 10.1 V.

PD70200 IC recognizes a V_{PP} to VPN_{IN} falling edge from Classification level to Mark level as being one event of the Two-Events Signature. If two such falling edges are detected, PD70200 will assert AT flag by means of an open drain MOSFET connected between AT_FLAG pin and VPN_{OUT} .

AT_FLAG pin is active low; a low impedance state between AT_FLAG and VPN_{OUT} indicates a valid Two-Events Classification Signature was received, and the Power Source is AT Type 2 compliant.

AT_FLAG MOSFET is capable of 5 mA of current and can be pulled up to V_{PP} .

1.1.4 Soft Start and Inrush Current Protection

PD70100/PD70200 IC contains an internal isolation switch, that provides ground isolation between Power Source and PD application during Detection and Classification phases. The isolation switch is a N-channel MOSFET, wired in a common source configuration where the MOSFET’s Source is connected to Power Source ground at VPN_{IN} , and the MOSFET’s Drain is connected to application’s primary ground at VPN_{OUT} .

Internal logic monitors V_{PP} to VPN_{IN} voltage and keeps the MOSFET in a high impedance state until V_{PP} to VPN_{IN} voltage reaches turn-on threshold of 36 V to 42 V. Once V_{PP} to VPN_{IN} voltage exceeds this threshold, the MOSFET is switched into one of two modes.

The mode into which the MOSFET is switched is determined by the voltage developed across the MOSFET, or put another way, the $V_{PN_{OUT}}$ to $V_{PN_{IN}}$ differential voltage. Two modes are defined below:

Table 1-1. Isolation Switch Modes

$V_{PN_{OUT}}$ to $V_{PN_{IN}}$	Mode	Description
>0.7 V	Soft Start Mode	Limits $V_{PN_{OUT}}$ current to 240 mA (typical)
≤ 0.7 V	Normal Operating Mode	Limits $V_{PN_{OUT}}$ current to 1.8 A (typical)

By controlling the MOSFET current based on $V_{PN_{OUT}}$ to $V_{PN_{IN}}$ voltage, inrush currents generated by fully discharged bulk capacitors can be limited. This method limits current to a maximum of 350 mA, compliant with IEEE 802.3af/at specification.

Soft Start current limiting is required to reduce occurrences of voltage sag at the PD input during device power-up. A comparison is shown in the following figure.

Figure 1-3. Startup Comparison

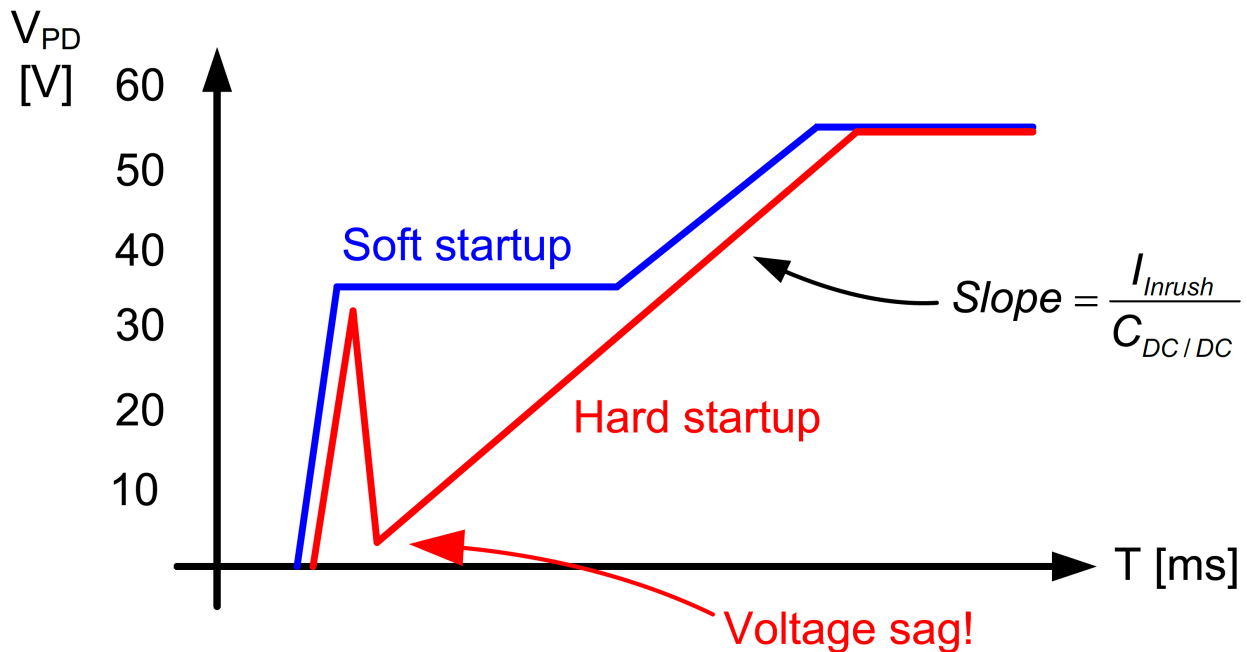

Once bulk capacitance has charged up to a point where $V_{PN_{OUT}}$ to $V_{PN_{IN}}$ differential voltage is less than 0.7 V, the isolation MOSFET is switched into normal operating mode with MOSFET current limit set at 1.8 A (typical), to provide over-current protection.

PD70100 and PD70200 ICs are different in their respective isolation MOSFET's continuous current handling capability:

- PD70100: 450 mA (max.)
- PD70200: 1123 mA (max.)

An adequate heat sink for the PD70100/PD70200 IC's exposed pad must be provided to achieve these current levels without damaging the IC. A large, heavy copper fill area and/or a heavy ground plane with Thermal Vias is recommended. Electrically the exposed pad ground plane should be connected to $V_{PN_{IN}}$.

Internal logic monitoring V_{PP} to $V_{PN_{IN}}$ will place the isolation switch MOSFET in a high impedance state if voltage between V_{PP} and $V_{PN_{IN}}$ drops below 31 V to 34 V.

1.1.5 Over-Current Protection

Over-current protection is provided on the PD70100/PD70200 IC using the Isolation MOSFET Switch, which limits the $V_{PN_{OUT}}$ current to 1.8 A during normal operation. See previous description of Soft Start.

1.1.6 Power Good

During Soft Start mode, the PD70100/PD70200 IC monitors $V_{PN_{OUT}}$ to $V_{PN_{IN}}$ differential voltage. When this voltage is less than 0.7 V (max.), the IC enters normal operation mode and the isolation switch current limit is increased to 1.8 A (typical). At this same 0.7 V (max.) threshold the Power Good signal is asserted by means of an open drain MOSFET between PGOOD and $V_{PN_{OUT}}$.

PGOOD pin is active low; a low impedance state between PGOOD and $V_{PN_{OUT}}$ indicates the Soft Start mode has finished and the isolation switch has transitioned into normal operating mode.

PGOOD MOSFET can handle current of 5 mA and can be pulled up to V_{PP} .

1.1.7 Auxiliary Voltage Output

PD70100/PD70200 IC provides a 10.5 V (typical) regulated output to be used as a start-up supply for DC/DC controllers whose V_{CC} is provided via a bootstrap winding. This regulated supply is available at V_{AUX} pin, and is referenced to $V_{PN_{OUT}}$ pin. V_{AUX} supply is designed for low-duty operation, and should not be designed as a primary housekeeping supply. The current capability is continuous 2 mA, with 10 mA peak (≤ 10 ms). V_{AUX} output is current-limited at 10 mA (min.).

For stability, the V_{AUX} regulator requires a minimum of 4.7 μ F ceramic capacitor connected directly between V_{AUX} and $V_{PN_{OUT}}$ pins.

1.1.8 Thermal Protection

Both PD70100 and PD70200 IC include temperature sensors which individually monitor both the isolation MOSFET and the Classification Current Source for over temperature conditions. In case of an over temperature condition, the sensor will activate protection circuitry which will disconnect its respective monitored function.

1.1.9 Bulk Capacitor Discharge

The bulk capacitor discharge circuitry eliminates the need to place a diode in series with the V_{PP} line to prevent an application's bulk capacitance from discharging through the detection resistor and the isolation switch MOSFET's body diode. Discharge current through the detection resistor can cause failure of the detection signature in cases where a PD is connected and the bulk capacitance is not fully discharged.

During normal operation, PD70100/PD70200 IC continuously monitors voltage at V_{PP} to $V_{PN_{IN}}$. Should V_{PP} to $V_{PN_{IN}}$ voltage fall below isolation switch turn-off threshold (31 V to 34 V), isolation switch MOSFET is immediately placed in a high-impedance state. At this point the internal logic monitors the voltage at V_{PP} to $V_{PN_{OUT}}$. If V_{PP} to $V_{PN_{OUT}}$ voltage is between 1.5 V to 32 V, a 23 mA (min.) constant current source is connected across the V_{PP} and $V_{PN_{OUT}}$ pins. This constant current source provides bulk capacitor discharge.

A 220 μ F bulk capacitance can be discharged from 32 V to 1.5 V in a maximal period of 292 ms.

2. Electrical Specifications

2.1 Absolute Maximum Ratings

Table 2-1. Absolute Maximum Ratings^{2, 3}

Parameter	Description
Supply Input Voltage (V_{PP}) Continuous	-0.3 V to 74 V_{DC}
Supply Input Voltage (V_{PP}) 1 ms pulse	-0.3 V to 88 V_{DC}
Port Negative Out Voltage (VP_{NOUT})	-0.3 V to 74 V_{DC}
R_{DET} Continuous	-0.3 V to 74 V_{DC}
R_{DET} 1 mS pulse	-0.3 V to 88 V_{DC}
R_{CLASS} , R_{REF}	-0.3 V to 5 V_{DC}
V_{AUX}	-0.3 V to 30 V_{DC}
PGOOD, AT_FLAG (with respect to VP_{NOUT}) Continuous	-0.3 V to 74 V_{DC}
PGOOD, AT_FLAG (with respect to VP_{NOUT}) 1 mS pulse	-0.3 V to 88 V_{DC}
ESD Protection ¹	±1.5 kV HBM
Maximum Operating Junction Temperature (T_A)	150 °C
Operating Ambient Temperature	-40 °C to 85 °C
Storage Temperature Range	-65 °C to 150 °C
Peak Package Solder Reflow Temp (40 seconds max exposure)	260 °C

1. All pins except pin 11 (V_{AUX}). Pin 11 ESD Protection ±150 V HBM.
2. No pin voltage can be higher than V_{PP} .
3. Exceeding these ratings could cause damage to the device. All voltages are with respect to VP_{NIN} except for V_{aux} , PGOOD and AT_FLAG with respect to VP_{NOUT} . Currents are positive into, negative out of specified terminal. These are stress ratings only and functional operation of the device at these or any other conditions beyond those indicated under “Recommended Operating Conditions” are not implied. Exposure to “Absolute Maximum Ratings” for extended periods may affect device reliability.

2.2 Typical Electrical Performance

Unless otherwise specified, the following specifications apply over the operating ambient temperature $-40\text{ °C} \leq T_{AMB} \leq 85\text{ °C}$. Production tests are done at 25 °C T_A .

2.2.1 Power Supply

Table 2-2. Power Supply

Parameter	Symbol	Min	Typ	Max	Units	Test Conditions/ Comment
Input Voltage	V_{PP}	0	55	57	V	Supports full IEEE 802.3af/at functionality
Power Supply Current at Operating Mode	—	—	1	3	mA	$V_{PP} = 55\text{ V}$

2.2.2 Detection Mode

Table 2-3. Detection Mode

Parameter	Symbol	Min	Typ	Max	Units	Test Conditions/Comment
Detection is connected. At this voltage range R_{DET} must be on.	DET_{RANGE}	1.3	—	10.1	V	Measured between V_{PP} and VP_{NIN}
Detection Switch ON Resistance PD-detection	R_{DET-on}	—	—	50	Ω	$2.5\text{ V} \leq (\Delta V_{PP} \text{ to } VP_{NIN}) \leq 10.1\text{ V}$ Measured between R_{DET} and VP_{NIN}
Detection is Disconnected	$R_{DET-off}$	10.1	—	12.8	V	Measured between V_{PP} and VP_{NIN}
Detection Switch OFF Resistance	$R_{DET-off}$	2.0	—	—	$M\Omega$	$12.8\text{ V} \leq (\Delta V_{PP} \text{ to } VP_{NIN}) \leq 57.0\text{ V}$ Measured between R_{DET} and VP_{NIN}
Input Offset Current	I_{OFFSET}	—	—	16	μA	1.1 V to 10.1 V $-40\text{ }^\circ\text{C} \leq T_J \leq 85\text{ }^\circ\text{C}$
	I_{OFFSET}	—	—	10	μA	1.1 V to 10.1 V $-40\text{ }^\circ\text{C} \leq T_J \leq 55\text{ }^\circ\text{C}$

2.2.3 Classification Mode

Table 2-4. Classification Mode

Parameter	Symbol	Min	Typ	Max	Units	Test Condition/Comment
Classification Current Source, Turn ON Threshold Range Measured at V_{PP}	$V_{THlow-on}$	11.4	—	13.7	V	Turn on for any I_{CLASS} while V_{PP} increases
Classification Current Source, Turn OFF ThresholdRangeMeasured at V_{PP}	$V_{THhigh-off}$	20.9	—	23.9	V	Turn off while V_{PP} increases
Current Limit Threshold	$I_{CLASSLIM}$	50.0	68	80.0	mA	—
Input Current I_{PP} When Classification Function is Disabled	$I_{CLASSDIS}$	—	—	4.0	mA	Class 0 $R_{CLASS} = \text{Disconnect}$

.....continued

Parameter	Symbol	Min	Typ	Max	Units	Test Condition/ Comment
Input Current I_{PP} When Classification Function is Enabled	$I_{CLASSEN}$	9.0	10.5	12.0	mA	Class 1 $R_{CLASS} = 133 \Omega \pm 1\%$
		17.0	18.5	20.0	mA	Class 2 $R_{CLASS} = 69.8 \Omega \pm 1\%$
		26.0	28.0	30.0	mA	Class 3 $R_{CLASS} = 45.3 \Omega \pm 1\%$
		36.0	40.0	44.0	mA	Class 4 $R_{CLASS} = 30.9 \Omega \pm 1\%$

2.2.4 Mark

Table 2-5. Mark

Parameter	Symbol	Min	Typ	Max	Units	Test Conditions/ Comment
Mark, Working Voltage Range	V_{MARK}	4.9	—	10.1	V	When voltage decreases Measured between V_{PP} to VPN_{IN}
Mark Current	I_{MARK}	0.25	—	4	mA	Chip current

2.2.5 Isolation Switch

Table 2-6. Isolation Switch

Parameter	Symbol	Min	Typ	Max	Units	Test Conditions/ Comment
Isolation Switch MOSFET Switches from Off to $I_{LIM-LOW}$	$V_{SW-START}$	36	—	42	V	—
Isolation Switch MOSFET Switched Off	V_{SW-OFF}	30.5	—	34.5	V	—
Startup Current Limit, I_{LIM}	$I_{LIM-LOW}$	105	240	325	mA	—
VPN_{IN} to VPN_{OUT} Threshold Voltage for $I_{LIM-LOW}$ to $I_{LIM-HIGH}$ Switchover	V_{DIFF}	—	—	0.7	V	When VPN_{IN} to $VPN_{OUT} \leq V_{DIFF}$, Isolating switch switches over from $I_{LIM-LOW}$ to $I_{LIM-HIGH}$
Over Current Protection Current Limit	OCP	1500	1800	2000	mA	—

.....continued

Parameter	Symbol	Min	Typ	Max	Units	Test Conditions/ Comment
Continuous Operation Load Current (PD70100)	I _{LOAD}	—	350	450	mA	Isolating switch at I _{LIM-HIGH}
Continuous Operation Load Current (PD70200)		—	600	1123		
Continuous Operation Total RDS _{ON}	SW-RDS _{ON}	—	—	0.6	Ω	Total resistance between VP _{NIN} and VP _{NOUT} Isolating switch at I _{LIM-HIGH}

2.2.6 DC/DC Capacitor Discharger

Table 2-7. DC/DC Capacitor Discharger

Parameter	Symbol	Min	Typ	Max	Units	Test Conditions/ Comment
DC/DC Input Capacitance	—	—	220	—	μF	For reference only Guaranteed by design (not tested in production)
Discharge Current	—	22.8	32	50	mA	7.0 V ≤ V _{PP} to VP _{NOUT} ≤ 30 V
Full Discharge Time for Full Discharge of Input Capacitance	T _{DSC}	—	—	500	ms	V _{PP} < UVLO threshold Guaranteed by design (not tested in production)

2.2.7 AT_FLAG

Table 2-8. AT_FLAG

Parameter	Symbol	Min	Typ	Max	Units	Test Conditions/ Comment
Output Low Voltage	—	—	—	0.4	V	I _{OL} = 0.75 mA
				2.5	V	I _{OL} MAX = 5 mA
Leakage Current	—	—	—	1.7	μA	V _{ATFLAG} = 57 V

2.2.8 PGOOD

Table 2-9. PGOOD

Parameter	Symbol	Min	Typ	Max	Units	Test Conditions/Comment
Output Low Voltage	—	—	—	0.4	μF	I _{OL} = 0.75 mA
				2.5	mA	I _{OL} MAX = 5 mA
Leakage Current	—	—	—	1.7	μA	V _{PGOOD} = 57 V

2.2.9 Thermal Shutdown

Table 2-10. Thermal Shutdown

Parameter	Symbol	Min	Typ	Max	Units	Test Conditions/ Comment
Thermal Shutdown Temperature	—	180	200	220	°C	—

2.2.10 VAUX

Reference to VP_{NOUT}.

Table 2-11. VAUX

Parameter	Symbol	Min	Typ	Max	Units	Test Conditions/Comment
V _{AUX} Output Voltage On	V _{AUX-on}	9.5	10.5	11.8	V	Isolating switch at I _{LIM-HIGH} and PGOOD = Low
Output Current Peak	I _{VAUXP}	0	—	10	mA	Capacitor = 30 μF When T _{LOAD} ≤ 5 mS Isolating switch at I _{LIM-HIGH} and PGOOD = Low
Output Continuous Current	I _{VAUXC}	0	—	2	mA	When T _{LOAD} ≤ 10 mS Isolating switch at I _{LIM-HIGH} and PGOOD = Low
V _{AUX} Output Current Limit	I _{VAUX}	10	—	32	mA	Isolating switch at I _{LIM-HIGH} and PGOOD = Low

2.3 Pin Description

The following illustration shows the device pinout, from the top view and bottom view.

Figure 2-1. Pinout Top View and Bottom View

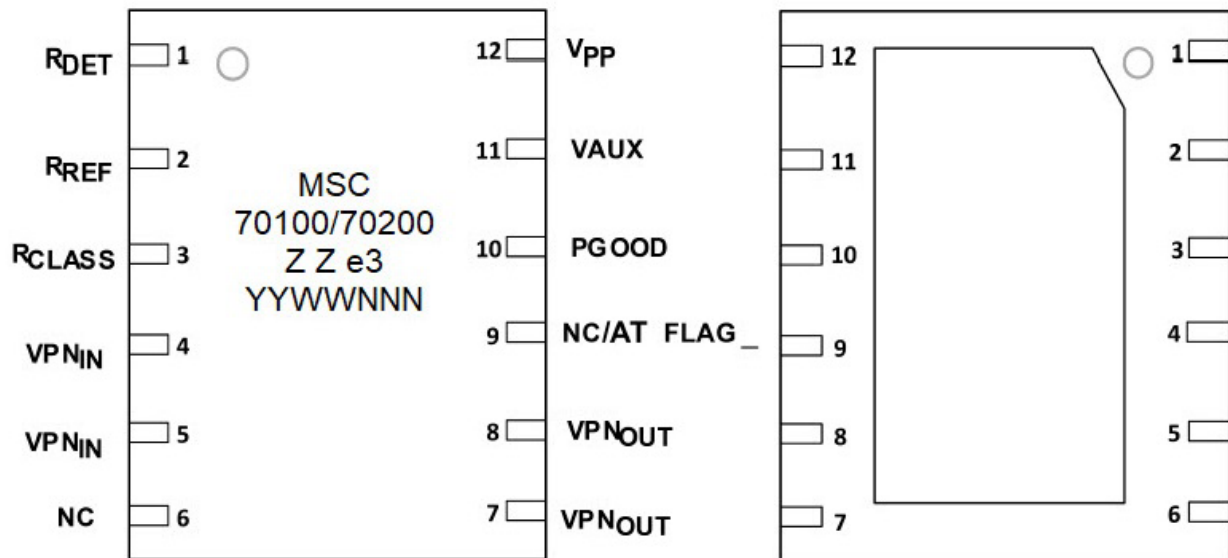

The following table lists the pin descriptions for the PD70100/PD70200 devices.

PD70100/PD70200

Electrical Specifications

Table 2-12. Pin Descriptions

Pin	Pin Name (PD70100)	Pin Name (PD70200)	Type	Description
1	R _{DET}	R _{DET}	—	Valid Detection resistor. Connect external 24.9 KΩ detection resistor between R _{DET} and V _{PP} .
2	R _{REF}	R _{REF}	—	Bias current resistor. Connect a 243 k 1% resistor between this pin and VP _{NIN} .
3	R _{CLASS}	R _{CLASS}	—	Power classification setting. Connect external class resistor between R _{CLASS} and VP _{NIN} .
4	VP _{NIN}	VP _{NIN}	Power	V _{Port} Negative input. Connected to the isolating SW input. N-channel MOSFET source. The exposed thermal pad should be connected to these pins.
5				
6	N.C.	N.C.	—	—
7	VP _{NOUT}	VP _{NOUT}	Power/Gnd	V _{port} Negative output. Connected to the isolating SW output. N-channel MOSFET Drain. Primary side Ground. A decent ground plane should be deployed around this pin whenever is possible.
8				
9	N.C.	AT_FLAG	Open drain	The two-event detector should discern between AF and AT classification waveforms and outputs the AT_FLAG (PD70200 only).
10	PGOOD	PGOOD	Open drain	After startup, a PGOOD flag is generated in order to optionally inform the application DC/DC converter that the power rails are ready.
11	V _{AUX}	V _{AUX}	Power	Auxiliary output voltage to VP _{NOUT} . Can be used for DC-DC startup for bootstrap initiation.
12	V _{PP}	V _{PP}	Power	High voltage positive input, reference to VP _{NIN} and high voltage positive input, reference to VP _{NOUT} during capacitor discharge.
EP	EPAD	EPAD	—	Connect to VP _{NIN} . EPAD should be connected to a large copper area for improved thermal management.

3. Package Specifications

This section provides information about the available package.

3.1 Package Outline Drawing

Figure 3-1. Package Drawing Dimensions and Measurements

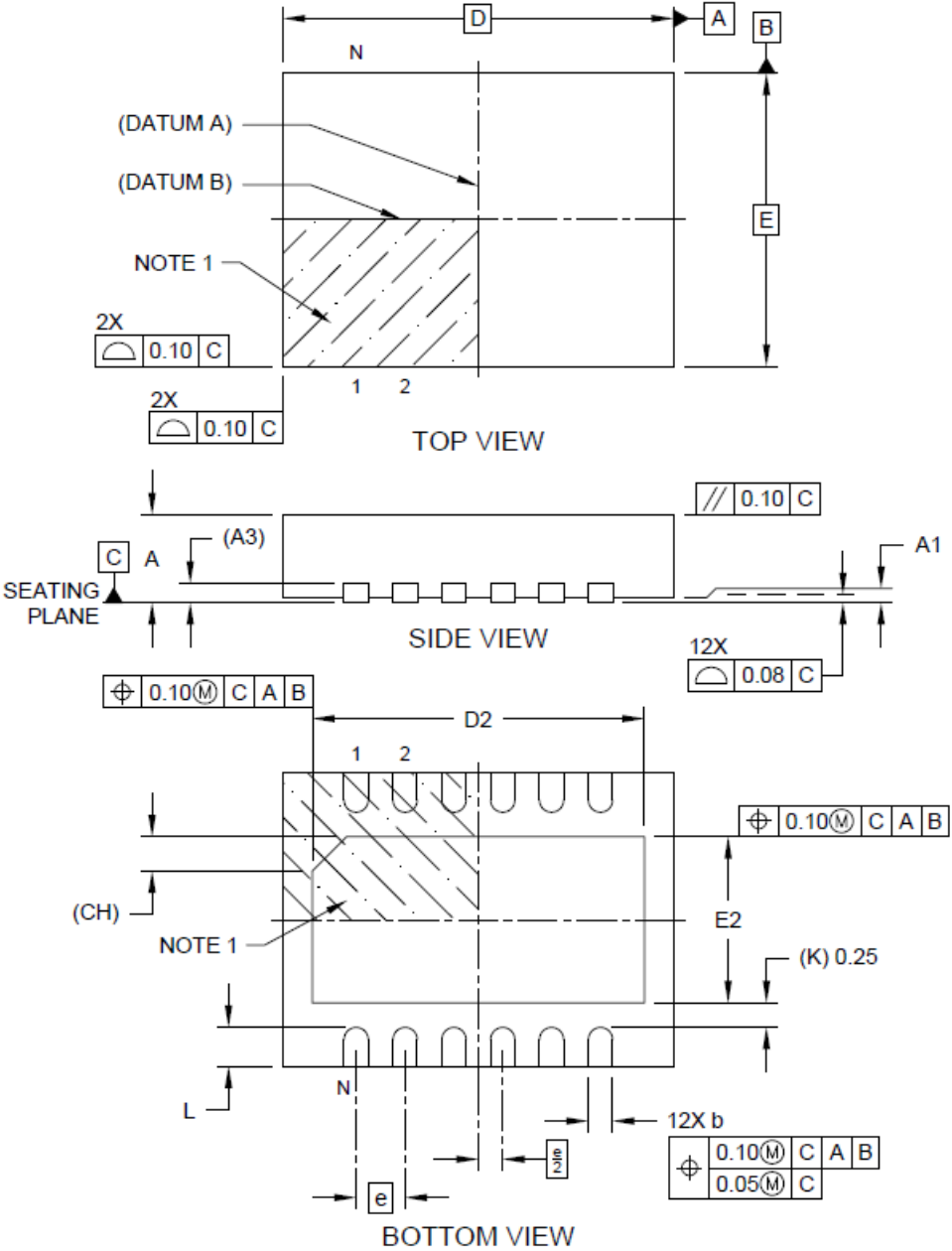

Table 3-1. Package Dimensions: DFN^{1, 2, 3, 4}

Units		Millimeters		
Dimension Limits		Min.	Nom.	Max.
Number of Terminals	N	12		
Pitch	e	0.05 BSC		
Overall Height	A	0.80	0.90	1.0
Standoff	A1	0.00	0.02	0.05
Terminal Thickness	A3	0.20 REF		
Overall Length	D	4.00 BSC		
Exposed Pad Length	D2	3.30	3.40	3.50
Overall Width	E	3.00 BSC		
Exposed Pad Width	E2	1.60	1.70	1.80
Terminal Width	b	0.20	0.25	0.30
Terminal Length	L	0.30	0.40	0.50
Terminal-to-Exposed-Pad	K	0.25 REF		
Index Chamfer	CH	0.35 REF		

1. Pin 1 visual index feature may vary, but must be located within the hatched area.
2. Package is saw singulated.
3. Dimensioning and tolerancing per ASME Y14.5M.
 - a. BSC: Basic Dimension. Theoretically exact value shown without tolerances.
 - b. REF: Reference Dimension, usually without tolerance, for information purposes only.
4. For the most current package drawings, please see the Microchip Packaging Specification located at www.microchip.com/packaging.

3.2 Thermal Specifications

The following table lists the thermal specifications for the PD70100 and PD70200 devices.

Table 3-2. Thermal Specifications

Parameter	Value
Typical thermal resistance: junction to ambient	40 °C/W
Typical thermal resistance: junction to case	4 °C/W

The θ_{JA} numbers are guidelines for the thermal performance of the device/pc-board system. All specifications assume no ambient airflow.

3.3 Recommended PCB Layout

The following figures show the PD70100/PD70200 PCB layout based on the IPC7093A October 2020 standard. All previously published footprints are still supported.

Figure 3-2. Solder Mask (Top View)

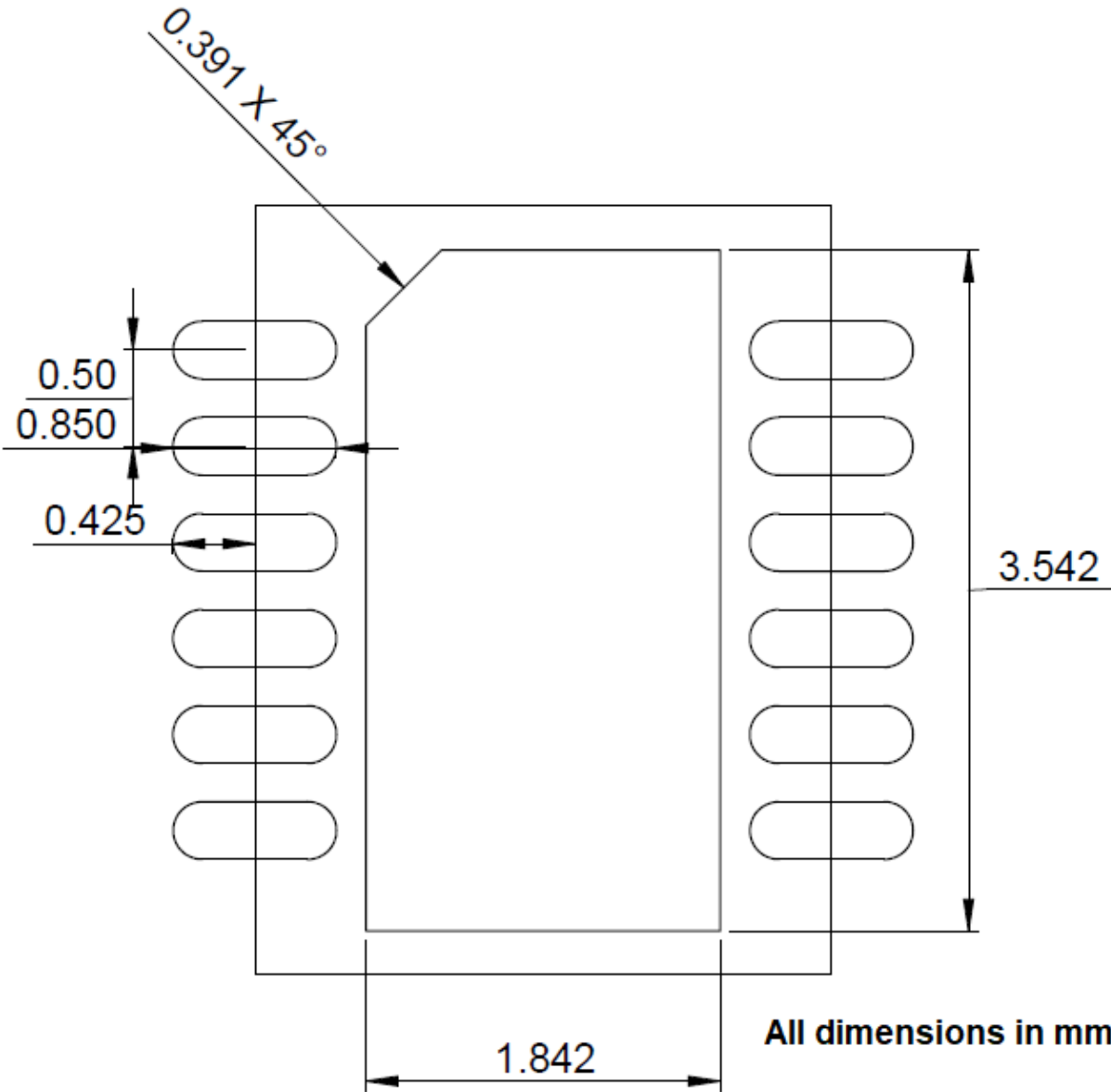

Figure 3-3. Copper Layer (Top View)

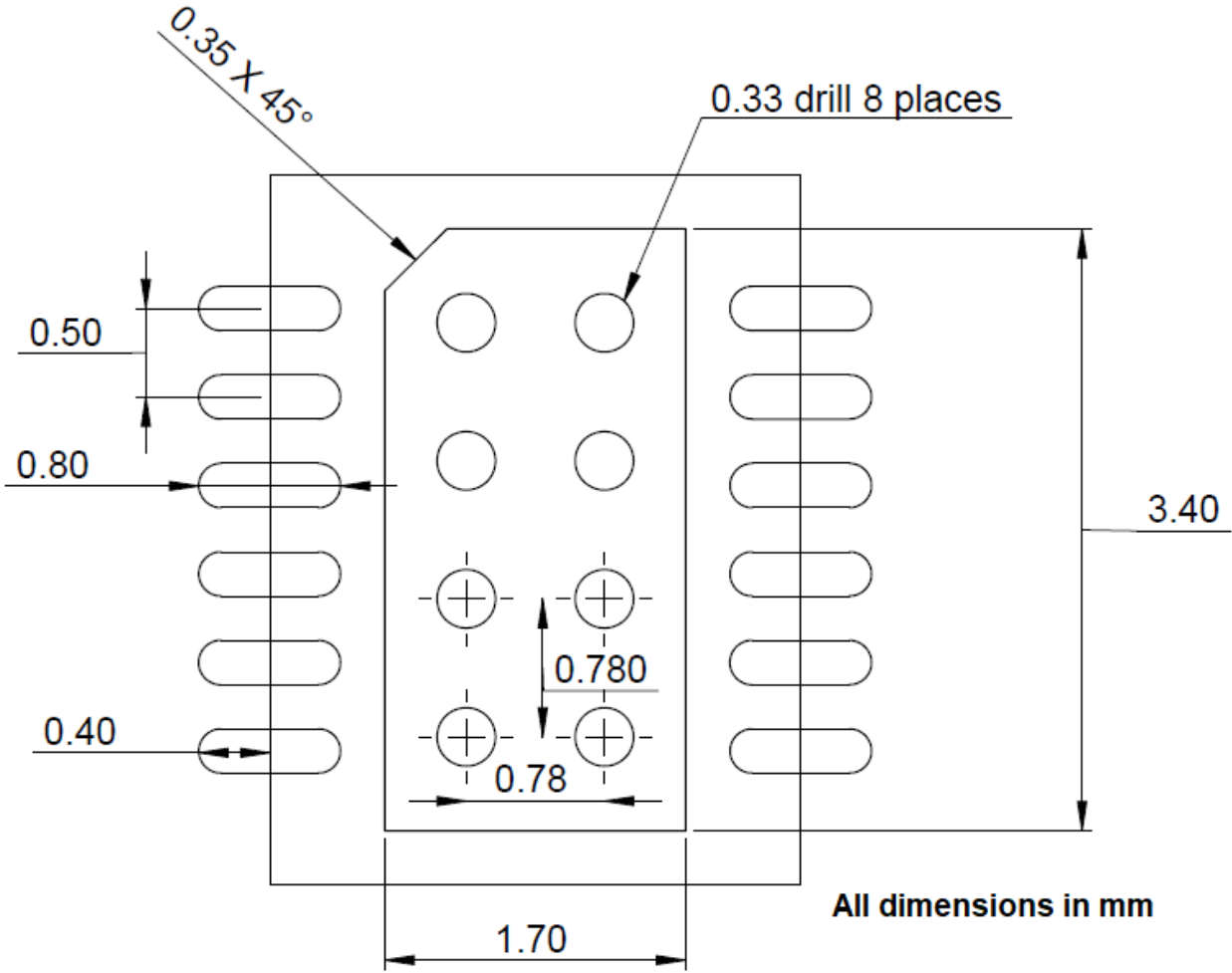
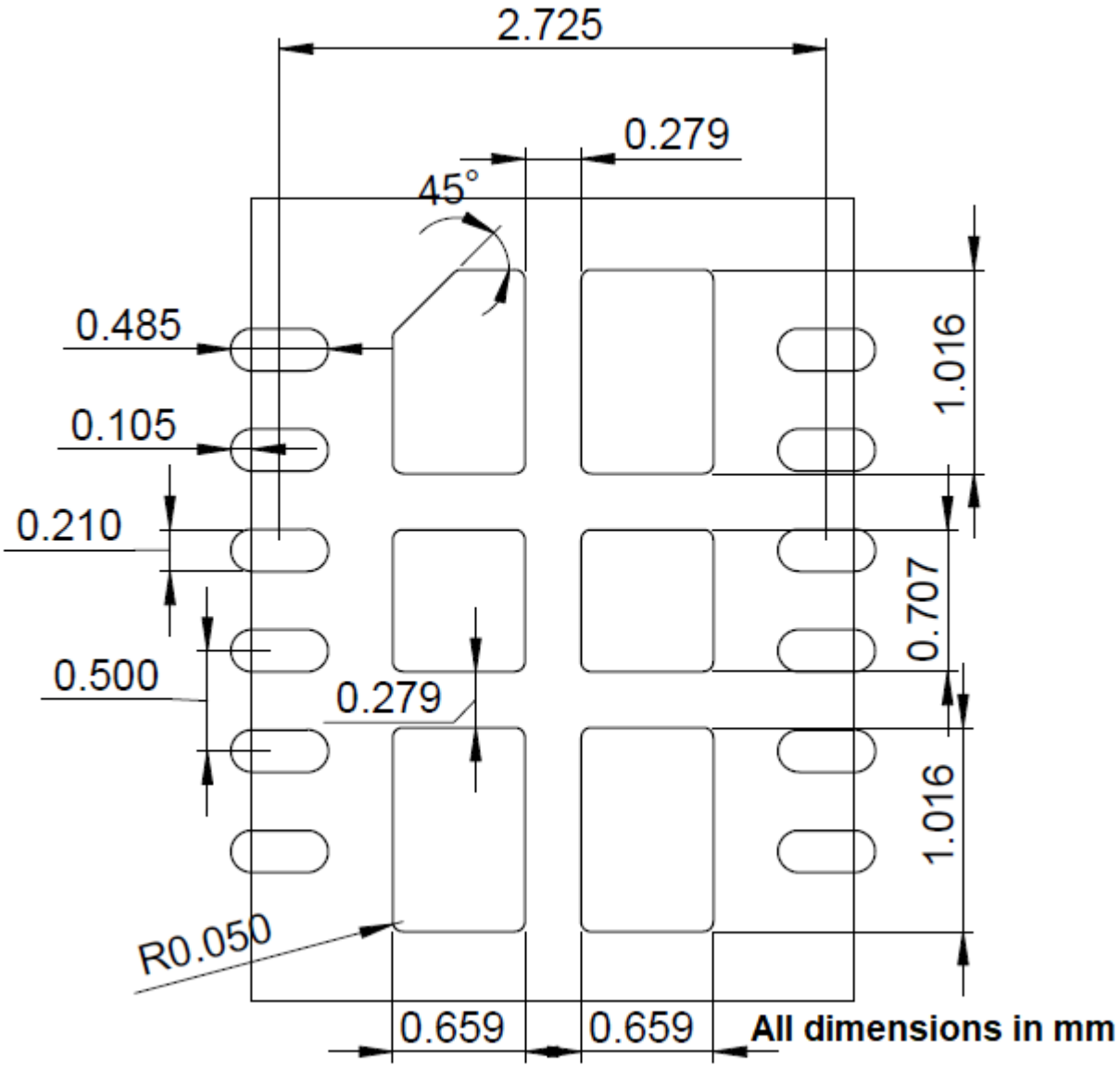
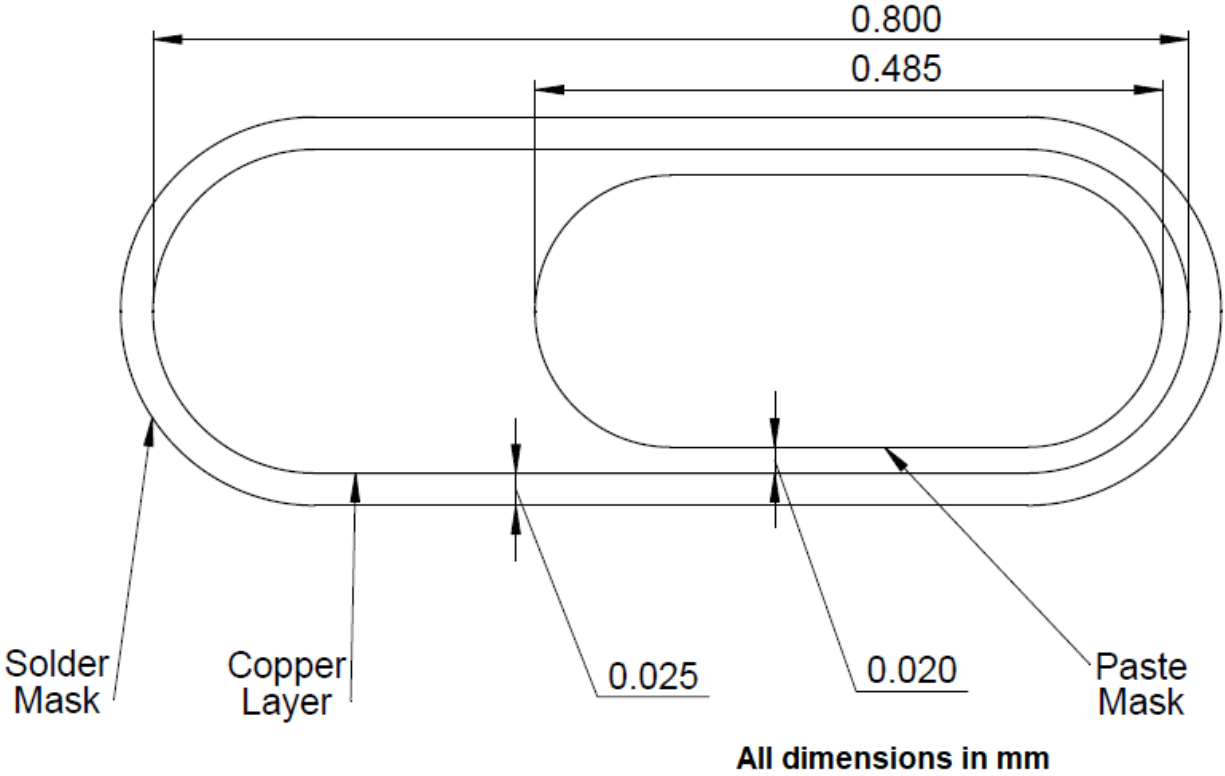

Figure 3-4. Paste Mask (Top View)



Note: Paste mask stencil is 5mil thick. All paste mask openings have a radius of 0.05 mm.

Figure 3-5. Pin Geometry



4. Ordering Information

Table 4-1. Ordering Information

Part Number	Packaging Type	Package	Part Marking
PD70100ILD-TR	Tape and Reel	DFN 4 mm × 3 mm 12 pins RoHS Compliant/Pb-free	MSC 70100 Z Z e3 ¹ YYWWNNN ²
PD70200ILD-TR	Tape and Reel	DFN 4 mm × 3 mm 12 pins RoHS Compliant/Pb-free	MSC 70200 Z Z e3 ¹ YYWWNNN ²

1. ZZ e3: ZZ = Random Character with no meaning, and e3 = 2nd level interconnect.
2. YY = Year, WW = Week, NNN = Trace Code.

5. References

- *AN3551 PD70101 and PD70201 PD Device Layout Guidelines*
- *AN3471 Designing a Type 1/2 802.3 or HDBaseT Type 3 Powered Device Using PD702x1 and PD701x1 ICs*
- *AN3472 Implementing Auxiliary Power in PoE*

6. Revision History

Revision	Date	Description
B	07/2021	<ul style="list-style-type: none"> Updated section Package Outline Drawing. Added section Recommended PCB Layout.
A	11/2020	<ul style="list-style-type: none"> Updated to Microchip template. Updated document number from PD-000303241 to DS00003639. Added Microchip Powered Device Products Offerings table. Updated Figure 1. Added References section.
4.0	08/2019	<ul style="list-style-type: none"> The package marking details were updated in the ordering information table. Figure 1 and Figure 4 were updated.
3.0	01/2018	<ul style="list-style-type: none"> The formatting of this document was updated to the latest template. MSL level was updated. Part marking was updated. Absolute Maximum Ratings were updated.
2.0	10/2015	<ul style="list-style-type: none"> The IC part number was updated from PD70100A to PD70100 (PDN 152044).
1.1	10/2014	<ul style="list-style-type: none"> The description of Pin 2 was updated.
1.0	03/2012	<ul style="list-style-type: none"> The document address footer was updated. Characteristics were updated.
0.6	07/2011	<ul style="list-style-type: none"> The specification was updated.
0.5	01/2011	<ul style="list-style-type: none"> Package was updated.
0.4	12/2010	<ul style="list-style-type: none"> Package was updated.
0.3	11/2010	<ul style="list-style-type: none"> Classification Pulse diagrams were added. Catalog numbers metrology was changed. Extensive changes were made to document format and Theory of Operation section. Package drawing was corrected. Product Highlight and Typical Characteristics were added.
0.1	04/2010	Initial Revision

The Microchip Website

Microchip provides online support via our website at www.microchip.com/. This website is used to make files and information easily available to customers. Some of the content available includes:

- **Product Support** – Data sheets and errata, application notes and sample programs, design resources, user's guides and hardware support documents, latest software releases and archived software
- **General Technical Support** – Frequently Asked Questions (FAQs), technical support requests, online discussion groups, Microchip design partner program member listing
- **Business of Microchip** – Product selector and ordering guides, latest Microchip press releases, listing of seminars and events, listings of Microchip sales offices, distributors and factory representatives

Product Change Notification Service

Microchip's product change notification service helps keep customers current on Microchip products. Subscribers will receive email notification whenever there are changes, updates, revisions or errata related to a specified product family or development tool of interest.

To register, go to www.microchip.com/pcn and follow the registration instructions.

Customer Support

Users of Microchip products can receive assistance through several channels:

- Distributor or Representative
- Local Sales Office
- Embedded Solutions Engineer (ESE)
- Technical Support

Customers should contact their distributor, representative or ESE for support. Local sales offices are also available to help customers. A listing of sales offices and locations is included in this document.

Technical support is available through the website at: www.microchip.com/support

Microchip Devices Code Protection Feature

Note the following details of the code protection feature on Microchip devices:

- Microchip products meet the specifications contained in their particular Microchip Data Sheet.
- Microchip believes that its family of products is secure when used in the intended manner and under normal conditions.
- There are dishonest and possibly illegal methods being used in attempts to breach the code protection features of the Microchip devices. We believe that these methods require using the Microchip products in a manner outside the operating specifications contained in Microchip's Data Sheets. Attempts to breach these code protection features, most likely, cannot be accomplished without violating Microchip's intellectual property rights.
- Microchip is willing to work with any customer who is concerned about the integrity of its code.
- Neither Microchip nor any other semiconductor manufacturer can guarantee the security of its code. Code protection does not mean that we are guaranteeing the product is "unbreakable." Code protection is constantly evolving. We at Microchip are committed to continuously improving the code protection features of our products. Attempts to break Microchip's code protection feature may be a violation of the Digital Millennium Copyright Act. If such acts allow unauthorized access to your software or other copyrighted work, you may have a right to sue for relief under that Act.

Legal Notice

Information contained in this publication is provided for the sole purpose of designing with and using Microchip products. Information regarding device applications and the like is provided only for your convenience and may be superseded by updates. It is your responsibility to ensure that your application meets with your specifications.

THIS INFORMATION IS PROVIDED BY MICROCHIP "AS IS". MICROCHIP MAKES NO REPRESENTATIONS OR WARRANTIES OF ANY KIND WHETHER EXPRESS OR IMPLIED, WRITTEN OR ORAL, STATUTORY OR OTHERWISE, RELATED TO THE INFORMATION INCLUDING BUT NOT LIMITED TO ANY IMPLIED WARRANTIES OF NON-INFRINGEMENT, MERCHANTABILITY, AND FITNESS FOR A PARTICULAR PURPOSE OR WARRANTIES RELATED TO ITS CONDITION, QUALITY, OR PERFORMANCE.

IN NO EVENT WILL MICROCHIP BE LIABLE FOR ANY INDIRECT, SPECIAL, PUNITIVE, INCIDENTAL OR CONSEQUENTIAL LOSS, DAMAGE, COST OR EXPENSE OF ANY KIND WHATSOEVER RELATED TO THE INFORMATION OR ITS USE, HOWEVER CAUSED, EVEN IF MICROCHIP HAS BEEN ADVISED OF THE POSSIBILITY OR THE DAMAGES ARE FORESEEABLE. TO THE FULLEST EXTENT ALLOWED BY LAW, MICROCHIP'S TOTAL LIABILITY ON ALL CLAIMS IN ANY WAY RELATED TO THE INFORMATION OR ITS USE WILL NOT EXCEED THE AMOUNT OF FEES, IF ANY, THAT YOU HAVE PAID DIRECTLY TO MICROCHIP FOR THE INFORMATION. Use of Microchip devices in life support and/or safety applications is entirely at the buyer's risk, and the buyer agrees to defend, indemnify and hold harmless Microchip from any and all damages, claims, suits, or expenses resulting from such use. No licenses are conveyed, implicitly or otherwise, under any Microchip intellectual property rights unless otherwise stated.

Trademarks

The Microchip name and logo, the Microchip logo, Adaptec, AnyRate, AVR, AVR logo, AVR Freaks, BesTime, BitCloud, chipKIT, chipKIT logo, CryptoMemory, CryptoRF, dsPIC, FlashFlex, flexPWR, HELDO, IGLOO, JukeBlox, KeeLoq, Klear, LANCheck, LinkMD, maXStylus, maXTouch, MediaLB, megaAVR, Microsemi, Microsemi logo, MOST, MOST logo, MPLAB, OptoLyzer, PackeTime, PIC, picoPower, PICSTART, PIC32 logo, PolarFire, Prochip Designer, QTouch, SAM-BA, SenGenuity, SpyNIC, SST, SST Logo, SuperFlash, Symmetricom, SyncServer, Tachyon, TimeSource, tinyAVR, UNI/O, Vectron, and XMEGA are registered trademarks of Microchip Technology Incorporated in the U.S.A. and other countries.

AgileSwitch, APT, ClockWorks, The Embedded Control Solutions Company, EtherSynch, FlashTec, Hyper Speed Control, HyperLight Load, IntelliMOS, Libero, motorBench, mTouch, Powermite 3, Precision Edge, ProASIC, ProASIC Plus, ProASIC Plus logo, Quiet-Wire, SmartFusion, SyncWorld, Temux, TimeCesium, TimeHub, TimePictra, TimeProvider, WinPath, and ZL are registered trademarks of Microchip Technology Incorporated in the U.S.A.

Adjacent Key Suppression, AKS, Analog-for-the-Digital Age, Any Capacitor, AnyIn, AnyOut, Augmented Switching, BlueSky, BodyCom, CodeGuard, CryptoAuthentication, CryptoAutomotive, CryptoCompanion, CryptoController, dsPICDEM, dsPICDEM.net, Dynamic Average Matching, DAM, ECAN, Espresso T1S, EtherGREEN, IdealBridge, In-Circuit Serial Programming, ICSP, INICnet, Intelligent Paralleling, Inter-Chip Connectivity, JitterBlocker, maxCrypto, maxView, memBrain, Mindi, MiWi, MPASM, MPF, MPLAB Certified logo, MPLIB, MPLINK, MultiTRAK, NetDetach, Omniscient Code Generation, PICDEM, PICDEM.net, PICKit, PICtail, PowerSmart, PureSilicon, QMatrix, REAL ICE, Ripple Blocker, RTAX, RTG4, SAM-ICE, Serial Quad I/O, simpleMAP, SimpliPHY, SmartBuffer, SMART-I.S., storClad, SQL, SuperSwitcher, SuperSwitcher II, Switchtec, SynchroPHY, Total Endurance, TSHARC, USBCheck, VariSense, VectorBlox, VeriPHY, ViewSpan, WiperLock, XpressConnect, and ZENA are trademarks of Microchip Technology Incorporated in the U.S.A. and other countries.

SQTP is a service mark of Microchip Technology Incorporated in the U.S.A.

The Adaptec logo, Frequency on Demand, Silicon Storage Technology, and Symmcom are registered trademarks of Microchip Technology Inc. in other countries.

GestIC is a registered trademark of Microchip Technology Germany II GmbH & Co. KG, a subsidiary of Microchip Technology Inc., in other countries.

All other trademarks mentioned herein are property of their respective companies.

© 2021, Microchip Technology Incorporated, Printed in the U.S.A., All Rights Reserved.

ISBN: 978-1-5224-8651-0

Quality Management System

For information regarding Microchip's Quality Management Systems, please visit www.microchip.com/quality.

Worldwide Sales and Service

AMERICAS	ASIA/PACIFIC	ASIA/PACIFIC	EUROPE
<p>Corporate Office 2355 West Chandler Blvd. Chandler, AZ 85224-6199 Tel: 480-792-7200 Tel: 480-792-7277 Technical Support: www.microchip.com/support Web Address: www.microchip.com</p> <p>Atlanta Duluth, GA Tel: 678-957-9614 Fax: 678-957-1455</p> <p>Austin, TX Tel: 512-257-3370</p> <p>Boston Westborough, MA Tel: 774-760-0087 Fax: 774-760-0088</p> <p>Chicago Itasca, IL Tel: 630-285-0071 Fax: 630-285-0075</p> <p>Dallas Addison, TX Tel: 972-818-7423 Fax: 972-818-2924</p> <p>Detroit Novi, MI Tel: 248-848-4000</p> <p>Houston, TX Tel: 281-894-5983</p> <p>Indianapolis Noblesville, IN Tel: 317-773-8323 Fax: 317-773-5453 Tel: 317-536-2380</p> <p>Los Angeles Mission Viejo, CA Tel: 949-462-9523 Fax: 949-462-9608 Tel: 951-273-7800</p> <p>Raleigh, NC Tel: 919-844-7510</p> <p>New York, NY Tel: 631-435-6000</p> <p>San Jose, CA Tel: 408-735-9110 Tel: 408-436-4270</p> <p>Canada - Toronto Tel: 905-695-1980 Fax: 905-695-2078</p>	<p>Australia - Sydney Tel: 61-2-9868-6733</p> <p>China - Beijing Tel: 86-10-8569-7000</p> <p>China - Chengdu Tel: 86-28-8665-5511</p> <p>China - Chongqing Tel: 86-23-8980-9588</p> <p>China - Dongguan Tel: 86-769-8702-9880</p> <p>China - Guangzhou Tel: 86-20-8755-8029</p> <p>China - Hangzhou Tel: 86-571-8792-8115</p> <p>China - Hong Kong SAR Tel: 852-2943-5100</p> <p>China - Nanjing Tel: 86-25-8473-2460</p> <p>China - Qingdao Tel: 86-532-8502-7355</p> <p>China - Shanghai Tel: 86-21-3326-8000</p> <p>China - Shenyang Tel: 86-24-2334-2829</p> <p>China - Shenzhen Tel: 86-755-8864-2200</p> <p>China - Suzhou Tel: 86-186-6233-1526</p> <p>China - Wuhan Tel: 86-27-5980-5300</p> <p>China - Xian Tel: 86-29-8833-7252</p> <p>China - Xiamen Tel: 86-592-2388138</p> <p>China - Zhuhai Tel: 86-756-3210040</p>	<p>India - Bangalore Tel: 91-80-3090-4444</p> <p>India - New Delhi Tel: 91-11-4160-8631</p> <p>India - Pune Tel: 91-20-4121-0141</p> <p>Japan - Osaka Tel: 81-6-6152-7160</p> <p>Japan - Tokyo Tel: 81-3-6880-3770</p> <p>Korea - Daegu Tel: 82-53-744-4301</p> <p>Korea - Seoul Tel: 82-2-554-7200</p> <p>Malaysia - Kuala Lumpur Tel: 60-3-7651-7906</p> <p>Malaysia - Penang Tel: 60-4-227-8870</p> <p>Philippines - Manila Tel: 63-2-634-9065</p> <p>Singapore Tel: 65-6334-8870</p> <p>Taiwan - Hsin Chu Tel: 886-3-577-8366</p> <p>Taiwan - Kaohsiung Tel: 886-7-213-7830</p> <p>Taiwan - Taipei Tel: 886-2-2508-8600</p> <p>Thailand - Bangkok Tel: 66-2-694-1351</p> <p>Vietnam - Ho Chi Minh Tel: 84-28-5448-2100</p>	<p>Austria - Wels Tel: 43-7242-2244-39 Fax: 43-7242-2244-393</p> <p>Denmark - Copenhagen Tel: 45-4485-5910 Fax: 45-4485-2829</p> <p>Finland - Espoo Tel: 358-9-4520-820</p> <p>France - Paris Tel: 33-1-69-53-63-20 Fax: 33-1-69-30-90-79</p> <p>Germany - Garching Tel: 49-8931-9700</p> <p>Germany - Haan Tel: 49-2129-3766400</p> <p>Germany - Heilbronn Tel: 49-7131-72400</p> <p>Germany - Karlsruhe Tel: 49-721-625370</p> <p>Germany - Munich Tel: 49-89-627-144-0 Fax: 49-89-627-144-44</p> <p>Germany - Rosenheim Tel: 49-8031-354-560</p> <p>Israel - Ra'anana Tel: 972-9-744-7705</p> <p>Italy - Milan Tel: 39-0331-742611 Fax: 39-0331-466781</p> <p>Italy - Padova Tel: 39-049-7625286</p> <p>Netherlands - Drunen Tel: 31-416-690399 Fax: 31-416-690340</p> <p>Norway - Trondheim Tel: 47-72884388</p> <p>Poland - Warsaw Tel: 48-22-3325737</p> <p>Romania - Bucharest Tel: 40-21-407-87-50</p> <p>Spain - Madrid Tel: 34-91-708-08-90 Fax: 34-91-708-08-91</p> <p>Sweden - Gothenberg Tel: 46-31-704-60-40</p> <p>Sweden - Stockholm Tel: 46-8-5090-4654</p> <p>UK - Wokingham Tel: 44-118-921-5800 Fax: 44-118-921-5820</p>

Mouser Electronics

Authorized Distributor

Click to View Pricing, Inventory, Delivery & Lifecycle Information:

[Microchip:](#)

[PD70100ILD-TR](#) [PD70200ILD-TR](#)