

Three-Phase Sensorless Fan Driver IC

FEATURES AND BENEFITS

- AEC-Q100 qualified
- Speed curve configuration via EEPROM
- I²C serial port
- Sinusoidal modulation for reduced audible noise and low vibration
- Sensorless (no Hall sensors required)
- Low R_{DS(ON)} power MOSFETs
- 3.3 V / 20 mA linear regulator
- PWM or analog speed input
- FG speed output
- Slew rate control
- Lock detection
- Soft start
- Low power standby mode
- Overcurrent protection
- Overvoltage protection

DESCRIPTION

The A5947-B three phase motor driver IC incorporates sensorless sinusoidal drive to minimize vibration for a wide variety of fan applications. Sensorless control eliminates the requirement for Hall sensors.

A flexible closed-loop speed control system is integrated into the IC. EEPROM is used to tailor the common functions of the fan speed curve to a specific application. This eliminates the requirement for a microprocessor-based system and minimizes programming requirements.

The A5947-B is available in a 20-lead TSSOP with exposed thermal pad (suffix LP).

PACKAGE:

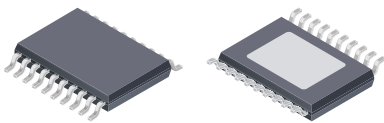

Not to scale

20-lead TSSOP
with exposed thermal pad
(LP package)

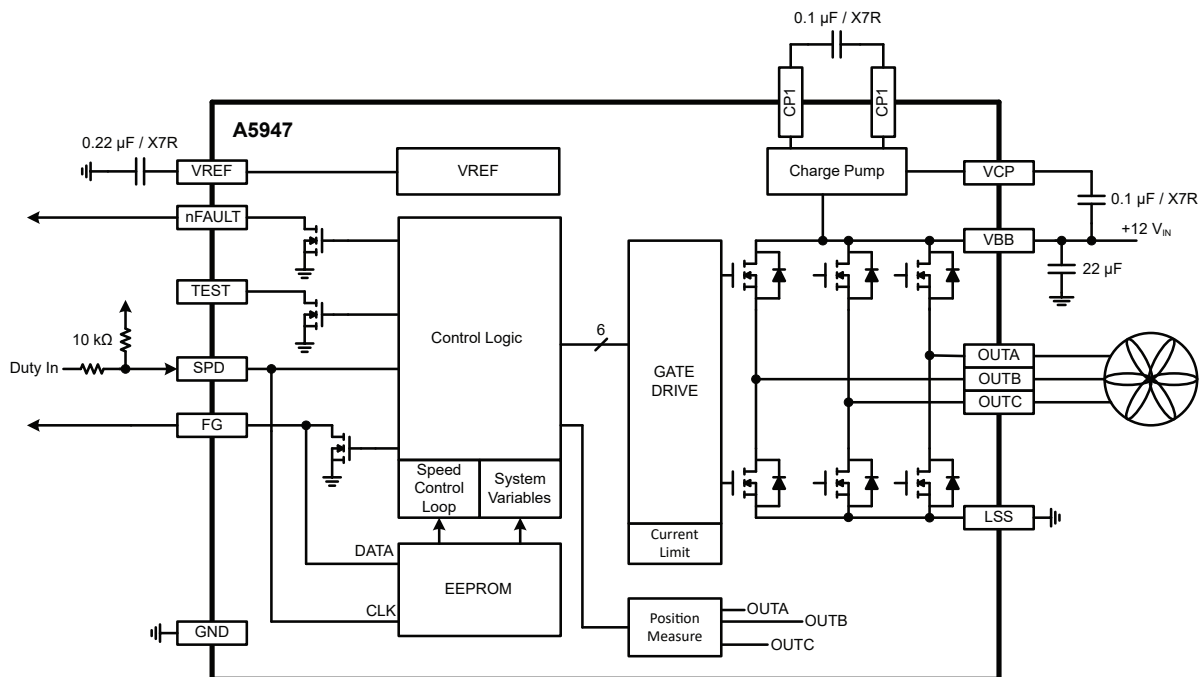

Figure 1: Typical Application

SELECTION GUIDE

Part Number	Operating Temperature Range (T _A) (°C)	Packaging	Packing
A5947KLPTR-B-T	-40 to 125	20-lead TSSOP with exposed power pad	4000 pieces per 13-inch reel



ABSOLUTE MAXIMUM RATINGS

Characteristic	Symbol	Notes	Rating	Unit
Supply Voltage	V _{BB}		-0.7 to 40	V
Logic Input Voltage Range	V _{IN}	SPD	-0.3 to 6	V
Logic Output	V _O	FG, nFAULT, TEST	-0.3 to 6	V
Output Current	I _{OUT}		3.6	A
Output Voltage	V _{OUT}	OUTA, OUTB, OUTC	V _{BB} + 1	V
VCP	V _{CP}		V _{BB} - 0.3 to V _{BB} + 8	V
CP1	V _{CP1}		-0.3 to V _{BB} + 0.3	V
CP2	V _{CP2}		V _{BB} - 0.3 to V _{CP} + 0.3	V
Maximum EEPROM write cycles	EEPROM _{W(MAX)}		1000	cycles
Junction Temperature	T _J		150	°C
Storage Temperature Range	T _{stg}		-55 to 150	°C
Operating Temperature Range	T _A	Range K	-40 to 125	°C

THERMAL CHARACTERISTICS

Characteristic	Symbol	Test Conditions*	Value	Unit
Package Thermal Resistance	R _{θJA}	20-lead TSSOP (package LP), on 2-sided PCB 1-in. ² copper	34	°C/W

*Additional thermal information available on the Allegro website.

Table of Contents

Features and Benefits.....	1	Basic Operation.....	6
Description.....	1	Flexible Speed Curve Options.....	8
Package.....	1	EEPROM Map.....	11
Typical Application.....	1	Serial Port Control Option.....	13
Specifications.....	2	Serial Port.....	15
Selection Guide.....	2	I ² C Timing Diagrams.....	15
Absolute Maximum Ratings.....	2	Write Command.....	16
Thermal Characteristics.....	2	Read Command.....	16
Pinout Diagram and Terminal List Table.....	3	Programming EEPROM.....	17
Electrical Characteristics.....	4	Pin Diagrams.....	19
Functional Description.....	6	Package Outline Drawing.....	20

PINOUT DIAGRAM AND TERMINAL LIST TABLE

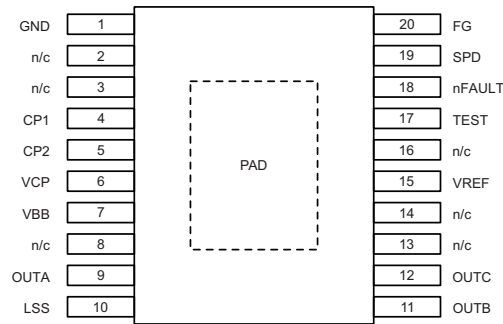

LP Package Pinouts

Terminal List Table

Terminal Number	Name	Function
1	GND	Ground
2,3	n/c	No connect
4	CP1	Charge pump capacitor
5	CP2	Charge pump capacitor
6	VCP	Charge pump capacitor
7	VBB	Input supply
8	n/c	No connect
9	OUTA	Motor terminal
10	LSS	Low side source connection
11	OUTB	Motor terminal
12	OUTC	Motor terminal
13,14	n/c	No connect
15	VREF	Reference voltage output
16	n/c	No connect
17	TEST	Logic output signal
18	nFAULT	Logic output signal
19	SPD	Logic input – speed demand
20	FG	Logic output signal
–	PAD	Exposed pad for enhanced thermal dissipation

ELECTRICAL CHARACTERISTICS [1]: Valid for $T_A = -40^{\circ}\text{C}$ to 125°C ; $V_{BB} = 4$ to 40 V, unless noted otherwise

Characteristics	Symbol	Test Conditions	Min.	Typ.	Max.	Unit
GENERAL						
VBB Supply Current	I_{BB}	Active mode (PWM duty < DC_ON)	–	13.5	15	mA
	I_{BBS}	$V_{BB} = 34$ V, standby mode	–	10	40	μA
Reference Voltage	V_{REF}	$I = 0$ to 20 mA, $V_{BB} = 6$ to 40 V	3.15	3.3	3.45	V
Charge Pump	V_{CP}	Relative to V_{BB} , $V_{BB} = 8$ V	6.5	7.2	7.7	V
		Relative to V_{BB} , $V_{BB} = 4$ V	3.5	3.7	–	V
POWER DRIVER						
Total Driver On-Resistance (Sink + Source)	$R_{DS(ON)}$	$I = 1.5$ A, $T_J = 25^{\circ}\text{C}$, $V_{BB} = 12$ V	–	510	–	$\text{m}\Omega$
		$I = 1.5$ A, $T_J = 125^{\circ}\text{C}$, $V_{BB} = 12$ V	–	760	860	$\text{m}\Omega$
		$I = 1.5$ A, $T_J = 25^{\circ}\text{C}$, $V_{BB} = 4$ V	–	680	–	$\text{m}\Omega$
		$I = 1.5$ A, $T_J = 125^{\circ}\text{C}$, $V_{BB} = 4$ V	–	950	1200	$\text{m}\Omega$
Source Driver On-Resistance	$R_{DS(ON)SRC}$	$T_J = 125^{\circ}\text{C}$, $V_{BB} = 12$ V	–	380	–	$\text{m}\Omega$
Sink Driver On-Resistance	$R_{DS(ON)SNK}$	$T_J = 125^{\circ}\text{C}$, $V_{BB} = 12$ V	–	380	–	$\text{m}\Omega$
Motor PWM Frequency	f_{PWM}	$T_A = 25^{\circ}\text{C}$ to 125°C	23.52	24.5	25.48	kHz
		$T_A = -40^{\circ}\text{C}$ to 125°C	23.03	–	25.97	kHz
SPEED CONTROL						
PWM Input Frequency Range	f_{PWMIN}		34	–	65000	Hz
Duty Cycle On Threshold	DC_{ON}	Relative to target	–0.5	–	0.5	%
Duty Cycle Off Threshold	DC_{OFF}	Relative to target	–0.5	–	0.5	%
SPD Standby Threshold (Analog)	V_{SPDTH}		0.43	0.7	1	V
SPD On Threshold	V_{SPDON}	$DC_{ON} = 10\%$	210	240	270	mV
SPD Off Threshold	V_{SPDOFF}	$DC_{OFF} = 8\%$	160	190	220	mV
SPD Max	V_{SPDMAX}		–	2.49	–	V
SPD ADC Resolution	V_{SPDLSB}		–	4.892	–	mV
SPD ADC Accuracy	SPD_{ACC}	$V_{BB} = 12$ V, $V_{SPD} = 0.2$ V to V_{SPDMAX}	–10	–	10	LSB
Speed Setpoint	f_{SPD}	Duty cycle input; $T_A = 25^{\circ}\text{C}$ to 125°C	–5	–	5	%
		Duty cycle input; $T_A = -40^{\circ}\text{C}$ to 125°C	–7	–	7	%

[1] Specified limits are tested at a single temperature and assured over temperature range by design and characterization.

Continued on next page...

ELECTRICAL CHARACTERISTICS [1] (continued): Valid for $T_A = -40^{\circ}\text{C}$ to 125°C ; $V_{BB} = 4$ to 40 V , unless noted otherwise

Characteristics	Symbol	Test Conditions	Min.	Typ.	Max.	Unit
PROTECTION CIRCUITS						
Lock Timing	t_{LOCK}	Relative to target	-5	-	5	%
VBB Undervoltage Threshold	V_{BBUVLO}	UVLO = 0, V_{BB} rising	3.7	3.85	4	V
		UVLO = 1, V_{BB} rising	8.4	8.65	9.02	V
VBB Undervoltage Hysteresis	V_{BBHYS}	UVLO = 0	160	300	480	mV
		UVLO = 1	1.8	2	2.2	V
Overcurrent Limit	I_{OCL}	$V_{\text{BB}} = 8\text{ V}$	2.5	3	3.5	A
Overcurrent Protection	I_{OCP}		3.94	7	-	A
VBB Overvoltage	V_{BBOV}	VBBOV = 0, V_{BB} rising	18.2	19	19.8	V
		VBBOV = 1, V_{BB} rising	36.8	37.5	39.3	V
VBB Overvoltage Hysteresis	V_{BBOVHYS}		1.5	2	2.5	V
VREF UVLO	V_{REFUVLO}	V_{REF} rising	2.9	3	3.15	V
VREF UVLO Hysteresis	V_{REFHYS}		150	250	350	mV
VREF Overcurrent Limit	V_{REFOCL}	$V_{\text{BB}} = 12\text{ V}$	30	65	120	mA
VCP UVLO	V_{CPUVLO}	V_{CP} rising	2.5	2.75	3.0	V
VCP UVLO HYS	$V_{\text{CPUVLOHYS}}$		-	110	-	mV
Thermal Shutdown Temperature	T_{JTSD}	Temperature increasing	150	165	180	$^{\circ}\text{C}$
Thermal Shutdown Hysteresis	ΔT_{J}	Recovery = $T_{\text{JTSD}} - \Delta T_{\text{J}}$	-	20	-	$^{\circ}\text{C}$
LOGIC/INPUT OUTPUT/I²C						
Logic Input Current (SPD, FG)	I_{IN}	$V_{\text{IN}} = 0$ to 5.5 V	-5	<1	5	μA
Logic Input Low Level	V_{IL}		0	-	0.8	V
Logic Input High Level	V_{IH}		2	-	5.5	V
Logic Input Hysteresis	V_{HYS}		200	300	600	mV
Output Saturation Voltage (FG, RD)	V_{SAT}	$I = 5\text{ mA}$	-	-	0.3	V
Output Leakage	I_{OUT}	$V = 5.5\text{ V}$, switch OFF	-	-	5	μA
I²C TIMING						
SCL Clock Frequency	f_{CLK}		3	-	400	kHz
Bus Free-Time Between Stop/Start	t_{BUF}		1.3	-	-	μs
Hold Time Start Condition	$t_{\text{HD:STA}}$		0.6	-	-	μs
Setup Time for Start Condition	$t_{\text{SU:STA}}$		0.6	-	-	μs
SCL Low Time	t_{LOW}		1.3	-	-	μs
SCL High Time	t_{HIGH}		0.6	-	-	μs
Data Setup Time	$t_{\text{SU:DAT}}$		100	-	-	ns
Data Hold Time	$t_{\text{HD:DAT}}$		0	-	900	ns
Setup Time for Stop Condition	$t_{\text{SU:STO}}$		0.6	-	-	μs

[1] Specified limits are tested at a single temperature and assured over temperature range by design and characterization.

FUNCTIONAL DESCRIPTION

Basic Operation

The A5947 targets fan applications to meet the objectives of minimal vibration, high efficiency, and the ability to customize the IC to the speed control specification.

In typical systems, an MCU is required to meet each application specification. The A5947 integrates the basic closed-loop speed control function, thus allowing elimination of the cost, PCB space, and programming requirements of a custom MCU.

For each specific application, the EEPROM settings can be created with the Allegro EVB and software.

The speed of the fan is typically controlled by variable duty cycle PWM input. The duty cycle is measured and converted to a 9-bit number. This 9-bit “demand” is translated to a PWM duty cycle applied to the motor windings, effectively a percentage of the power supply voltage.

Protection features include lock detection with restart, overcurrent limit, overvoltage protection, motor output short circuit, supply undervoltage monitor, and thermal shutdown.

Standby mode can be achieved by holding SPD pin low for longer than the programmed lock off-time.

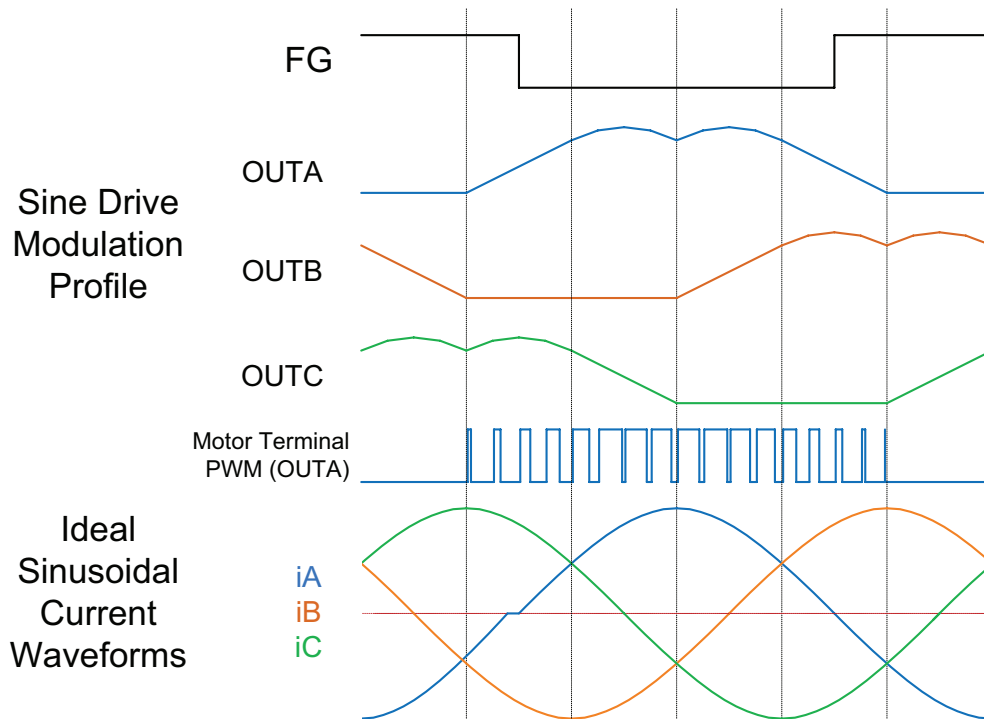

Figure 2: Sinusoidal Drive Sequence

FG. Open-drain output, represents the speed of the motor for normal operation. The electrical frequency of the motor may be different than FG output.

$$f_{ELEC} = f_{FGOUT} \times \text{NumberOfPolePairs} / 2$$

$$f_{FGOUT} = f_{ELEC} \times 2 / \text{NumberOfPolePairs}$$

$$RPM = f_{ELEC} \times 60 / \text{NumberOfPolePairs}$$

$$RPM = 30 \times f_{FGOUT}$$

Additionally, the FG pin serves as the data line, (SDA) for I²C communication.

SPD. Speed demand input. The demand can be in the form of duty cycle, analog voltage, or direct I²C command.

An EEPROM setting will determine choice of duty or analog input. Additionally, the SPD pin serves as the clock line (SCL) for I²C communication.

Analog control. Voltage applied to SPD pin will set speed demand. An internal 9-bit A/D converter will translate the input to a speed demand.

$$\text{Applied Duty (\%)} = \text{Code} / 511$$

$$\text{Code} = V_{IN(\text{SPD})} / 4.89 \text{ mV} + 2 \text{ where code} = [0 \dots 511]$$

TEST. Open drain output, low when motor off, high at end of open loop startup.

nFAULT. An active low output to represent the following fault conditions: VBB undervoltage, VBB overvoltage, thermal shutdown, VCP undervoltage, rotor lock, and output VDS fault (OCP).

OCL. Overcurrent limit. When the OCL level is reached, the PWM on pulses will be terminated early to prevent further increase of current.

SLEW. The motor output slew rate (dv/dt) can be reduced by adjustment of EEPROM variable SLEW.

SLEW		Nominal (ns)
MSB	LSB	
0	0	100
0	1	150

OCP. Overcurrent protection, VDS monitor. To protect from short-to-ground, shorted load, or short-to-battery conditions for the motor lines, the voltage across the power outputs is monitored at all times when the MOSFET is turned on. There will be a short blank time before the motor outputs are disabled if the overcurrent protection limit I_{OCP} is exceeded. The fault is latched off. EEPROM bit OCPOPT will select option to reset latch with choice of lock timeout or PWM on/off command.

Note: During the shorted event, the absolute maximum ratings may be exceeded for the blank time.

OVP. The A5947 outputs can be disabled if power supply voltage exceeds programmed threshold. With OVPOPT = 1, the outputs will remain disabled for t_{LOCK} to allow motor to coast down to slower speed. After t_{LOCK}, a normal startup will resume operation assuming V_{BB} has fallen below the hysteresis level.

VBBOV	VBBODIS	OVPOPT	OVPTH	OVP Function
X	1	1	Outputs continue to run with V _{BB} > V _{BBOV}	Disabled
0	X	0	19 V	Disable outputs when V _{BB} > V _{BBOV}
0	0	1	19 V	Latch off for t _{LOCK}
1	X	0	38 V	Disable outputs when V _{BB} > V _{BBOV}
1	0	1	38 V	Latch off for t _{LOCK}

Standby Mode. A low power mode is activated if SPD pin is held low. Standby Mode will turn off all circuitry including charge pump and VREF. Upon power up, the A5947 will immediately wake up. If SPD remains low for the programmed lock time, standby mode will be activated. Standby mode can be disabled via EEPROM bit.

Lock Detect. The A5947 will turn off for the programmed time (t_{LOCK}) when the rotor is in a locked condition. A normal startup occurs after the lock timeout. EEPROM variable RETRY provides an option to count the number of lock events and prevent restart attempts after the count is exceeded. To resume operation after retry count is exceeded, PWM must be cycled OFF→ON. Lock event count can also be triggered by thermal shutdown events, OVP, or OCP events.

Thermal Shutdown (TSD). The A5947 protects itself from overheating with an internal thermal monitoring circuit. If the junction temperature exceeds the upper threshold T_{JTSD}, the outputs will be disabled, and a lock timeout will be triggered. Device temperature must fall below the hysteresis level, ΔT_J, to allow a normal restart sequence.

EEPROM Security. EEPROM can be password protected to prevent readback of the stored configuration. The IC will be shipped without password protection. Sequence to protect IC:

1. Power up.
2. Write 16-bit number to EEPROM register 7 per normal I²C EEPROM sequence.
3. Remember this password.
4. Power down.

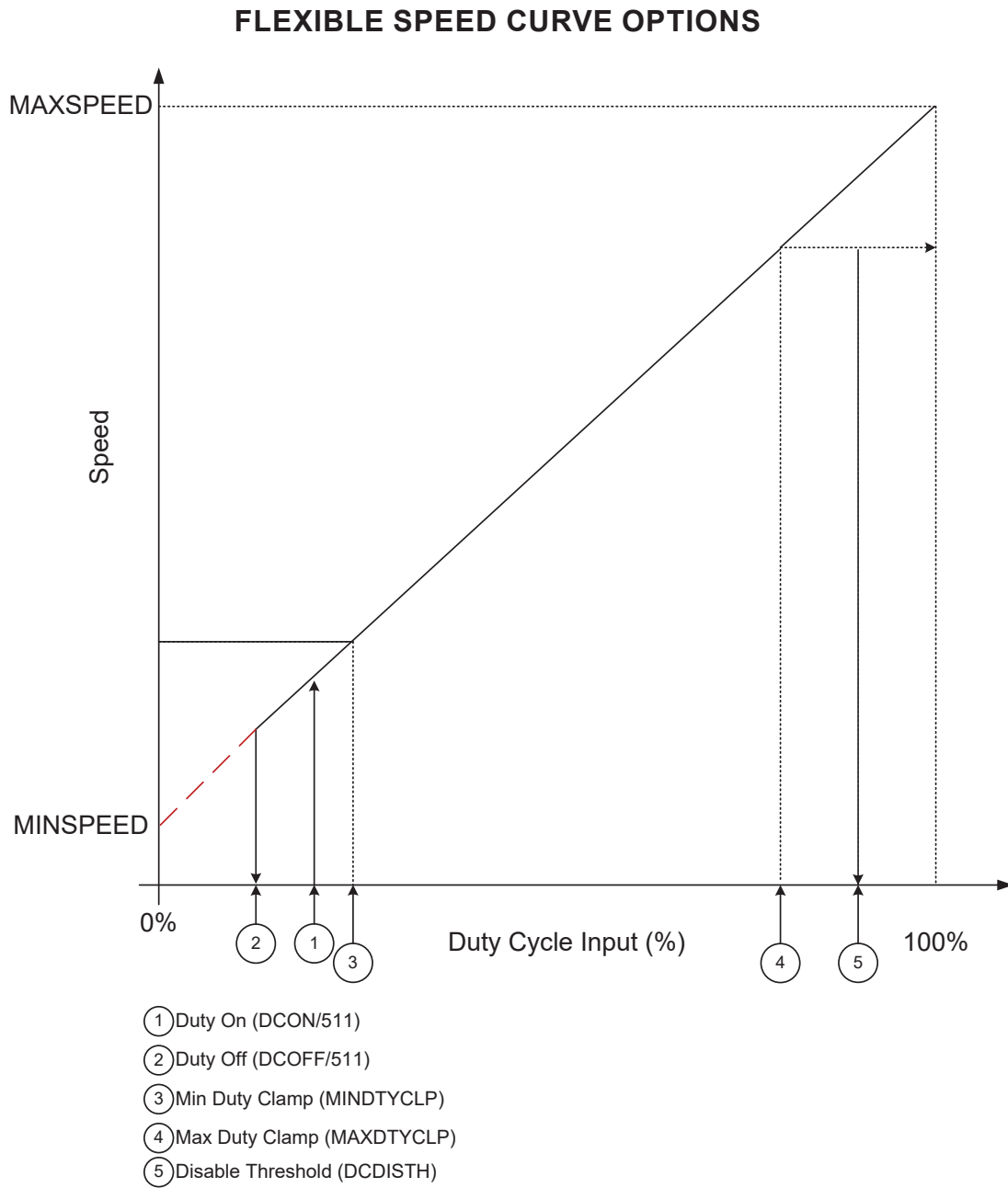

Figure 3: Slope is set by selection of 100% speed, (MAXSPEED), and y-intercept (MINSPEED).

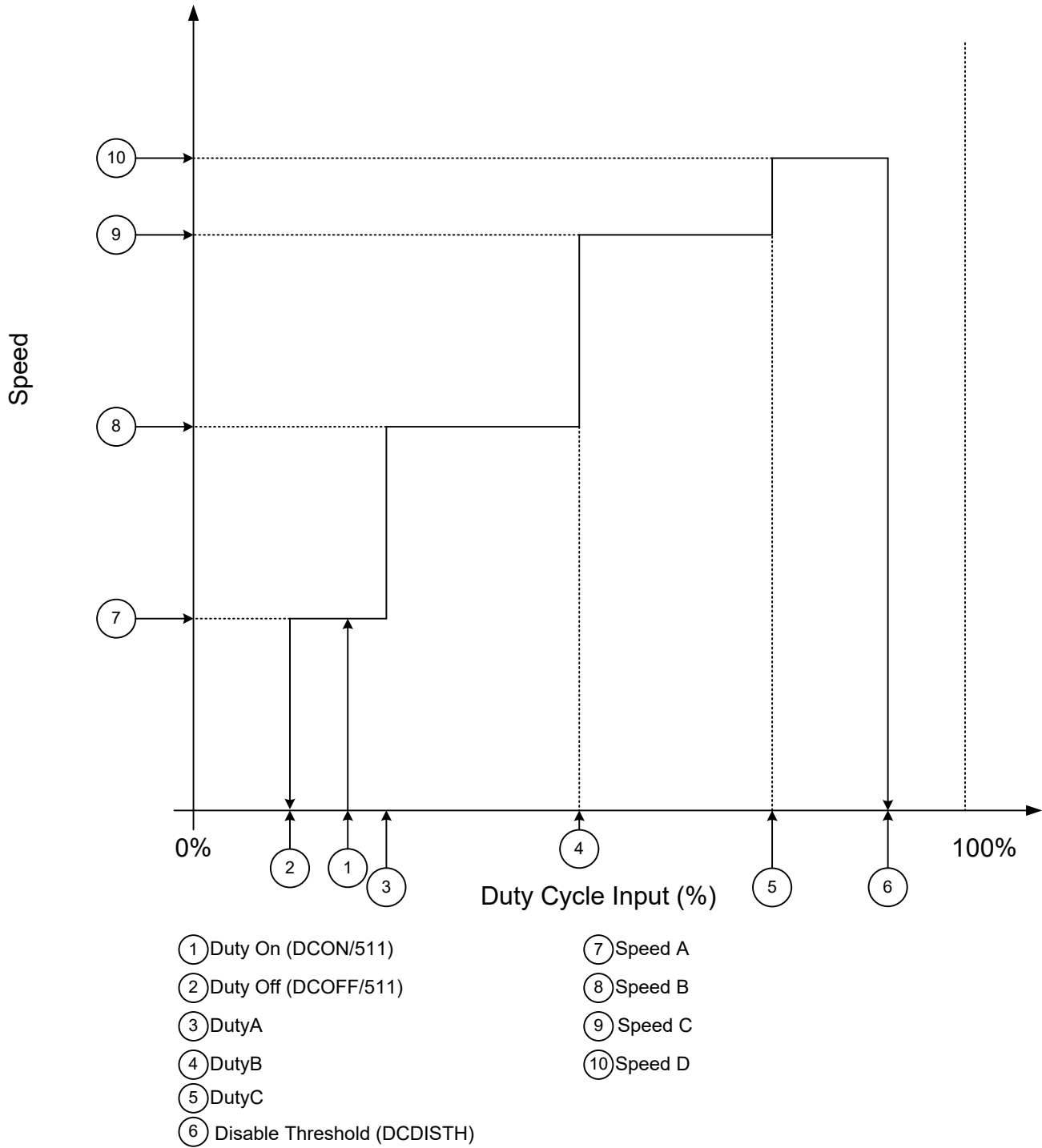

Figure 4: Staircase Curves

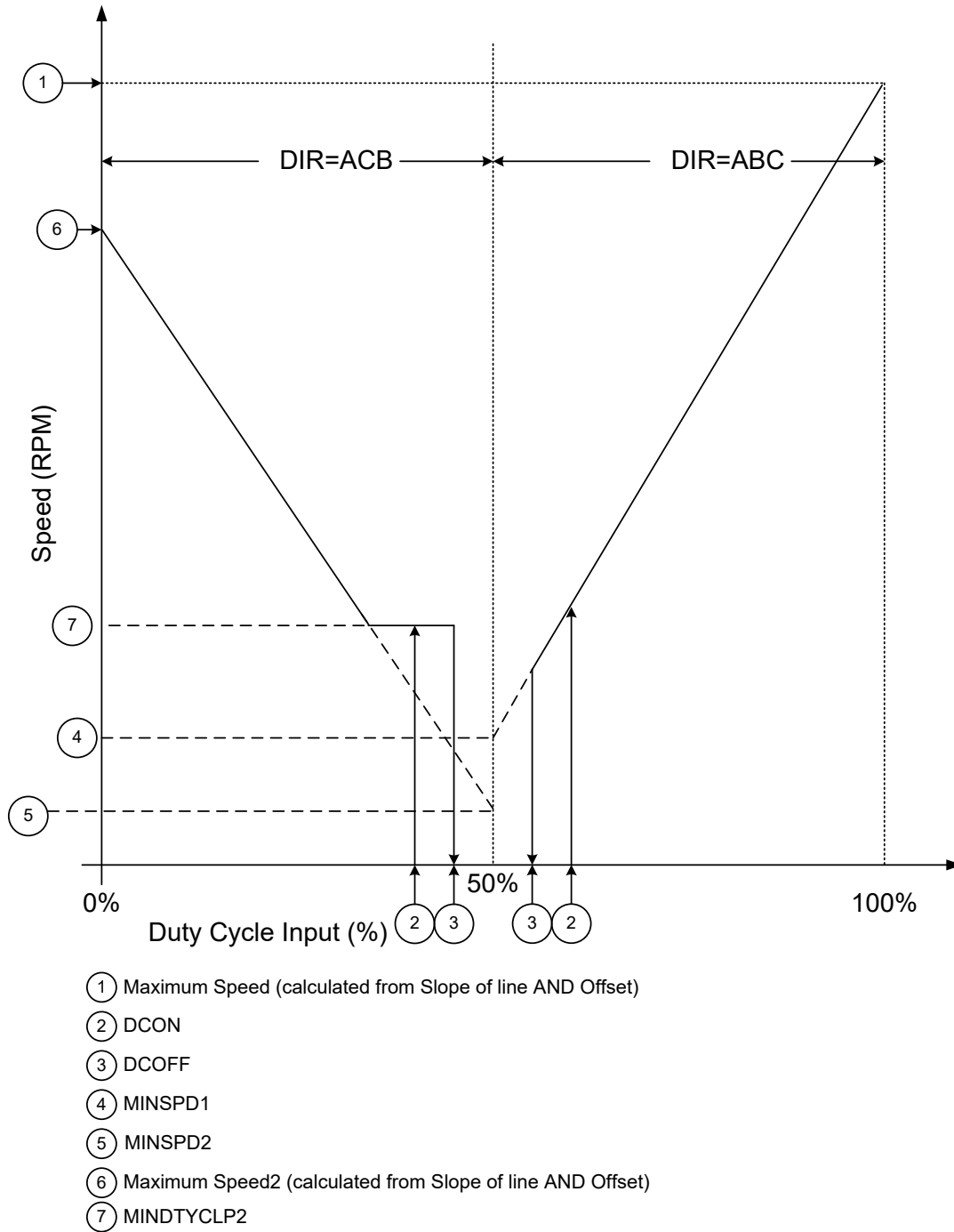

Figure 5: Direction Change Based on 50% Reference

EEPROM MAP

ADDR	REG	Bits	Name	Description	Default Setting	Default Value
0	64	15:0	Reserved	Allegro reserved	n/a	
1	65	15:0	Reserved	Allegro reserved	n/a	
2	66	15:0	Reserved	Allegro reserved	n/a	
3	67	15:0	Reserved	Allegro reserved	n/a	
4	68	15:0	CAS	Customer Code	n/a	
5	69	15:0	Reserved	Allegro reserved	n/a	
6	70	15:0	Extra	For customer use	n/a	
7	71	15:0	PASSWORD	Password	n/a	
8	72	3:0	MAXDTYCLP	Range = 100% to 76.5%, LSB = 1.56%	100%	0
		9:4	MINDTYCLP	Range = 0 to 50% LSB = 0.8%	0%	0
		13:10	DCDISTH	Range = 100% to 78.2%, LSB = 1.56% DCDISTH(%) = 100% - (code - 1) × 1.56%	Disabled	0
		15:14	DCDISHYS	0.8% / 1.6% / 2.4% / 3.2%	0.8%	0
9	73	8:0	STRTDMD	Range = 0 to VBBRNG, LSB = VBBRNG / 511	1.41 V	38
		15:9	DMDPOST	Range=0 to 100%, LSB = 0.8%	87.4%	111
10	74	7:0	TCOAST	Coast time for brake or dir change	3 seconds	30
		15:8	OPNLPMAX	Max speed limit for open loop mode	15104 rpm	59
11	75	7:0	ACCELT	Range = 0 to 10.2 seconds, LSB = 40 ms	760 ms	19
		15:8	ACCEL	Range = 0 to 99.6 Hz/s LSB = 0.41	37.5 Hz/s	96
12	76	7:0	DCON	Range = 0 to 100% LSB = 0.4%	9.8%	25
		10:8	DCHYS	Range = 0.6 to 6.1% LSB = 0.8%	2.9%	3
13	77	3:0	DMDRMPAL	Range = 3.8 to 63.8 ms/count, LSB = 4.0	23.8 ms/count	5
		7:4	DMDRMPAH	Range = 2.0 to 32/count, LSB = 2.0	5.8 ms/count	2
		11:8	DMDRMPDL	Range = 3.8 to 63.8 ms/count, LSB = 4.0	27.8 ms/count	6
		15:12	DMDRMPDH	Range = 3.8 to 63.8 ms/count, LSB = 4.0	27.8 ms/count	6
14	78	6:0	KP	Closed Loop Kp	16	16
		7	PIGAIN	0:low Speed, 1:high Speed	0	0
		15:8	KI	Closed Loop	12	12
15	79	7:0	MAXSPD	Maximum Electrical Frequency	509 Hz	24
		15:8	TLOCK	0 to 25.4 seconds, 255 = latching	5 seconds	50
16	80	13:0	SPDSLPI	Calculated Slope of Speed Curve	10000 rpm Maxspeed	1252
17	81	11:0	MINSPEED	Range = 0 to 4095, res = 1 rpm	0 rpm	0
		15:12	TRAPDITY	Duty to switch to trap drive LSB = 6.25%	Sine Only	0
18	82	0	CL	Speed Control Mode 0 = OpenLoop, 1 = Closed	Open	0
		1	DIR	0 = A→C→B, 1 = A→B→C	A→C→B	0
		2	UVLO	0 = Low (3.85 V), 1 = High (8.65 V)	High	1
		3	SPDSEL	Speed Control Select 0 = PWM Duty, 1 = Analog	PWM	0
		6:4	PP	Pole Pair = PP+1	2 Pole-Pair	1
		8:7	ALIGN	0:3 → 500 ms / 1 second / 1.5 seconds / 2 seconds	1 second	1
		9	OVPOPT	0: disable, 1: lock detect	Lock Detect	1
		10	SLEW	Output dv/dt select	100 ns	0
		11	Unused	Must Set to 0	n/a	0
		13:12	BEMFHYS	Bemf Hys Level for Startup	40 mV	1
		14	SOWAUTO	Initial Value of Window	21 degrees	1
		15	OCPOPT	0 = Reset after Tlock, 1= After PWM on/off	Tlock	0

Continued on next page...

EEPROM MAP (continued)

ADDR	REG	Bits	Name	Description	Default Setting	Default Value
19	83	0	STBYDIS	Standby Mode 0 = Enable, 1 = Disable	Disabled	1
		1	PWMF	Motor PWM Selection	24 kHz	0
		2	DTYIN	0: Low F (34hz), 1: High F	Low	0
		4:3	BEMFILT	Time Filter	4 μ s	0
		5	TCENB	Temperature Compensation 0: Off, 1: On	Disabled	0
		6	WINDMILL	0: Resynchronize, 1: brake until stop	Resynchronize	0
		7	POSTCOAST	0 = 500 ms, 1 = 100 ms	500 ms	0
		9:8	DITHDT	Dither time (ms per step)	1.3	0
		11:10	DITHSTP	Dither number of steps	8	0
		12	DITHENB	0 = Disabled, 1 = Enable dither function	Disabled	0
		13	VBBOVDIS	0 = Enable, 1 = Disable	Enabled	0
		14	VBBOV	0 = 19 V, 1 = 38 V	19 V	0
		15	VBBRNG	0 = 19 V, 1 = 38 V	19 V	0
		20	84	0	DTYINV	0 = Normal, 1 = Invert
1	Reserved			Allegro Reserved – Set to One	1	1
2	STAIR			1 = Enable Staircase	Disabled	0
3	DIR50			1: Enable Direction change based on 50% duty	Disabled	0
4	BRKOFF			0 = coast, 1 = Brake	Disabled	0
6:5	STRT			0 = Align, 1 = One cycle, 2 = IPD-ZT, 3 = IPD-T	One Cycle	1
7	IPDTP			0 = Slow Decay, 1 = Fast Decay	Slow	0
8	Reserved				Set to 1	1
14:9	DUTYC			Range = 1.37 to 100%, LSB = 1.56%	60.86%	38
21	85			7:0	SPEEDA	Range = 0 to 8160, RES 32 rpm
		15:8	SPEEDB	Range = 0 to 8160, RES 32 rpm	3008 rpm	94
22	86	7:0	SPEEDC	Range = 0 to 8160, RES 32 rpm	4000 rpm	125
		15:8	SPEEDD	Range = 0 to 8160, RES 32 rpm	4992 rpm	156
23	87	5:0	DUTYA	Range = 1.37 to 100%, LSB = 1.56%	20.16%	12
		13:8	DUTYB	Range = 1.37 to 100%, LSB = 1.56%	40.51%	25
24	88	11:0	MINSPD2	Range=0 to 4095, res = 1 rpm (DIR50 mode)	0	0
		15:12	RETRY	Number of retry attempts when rotor locked (0 = function disabled)	Disabled	0
25	89	13:0	SPDSL2	Calculated Slope of Speed Curve (DIR50 and dual slope mode)	10000 rpm Maxspeed	1252
26	90	5:0	MINDTYCLP2	Range = 0 to 50%, LSB = 0.8% (DIR50)	0	0
		13:6	SLPSWDTY	Slope Switch Duty for dual slope mode	Disabled	0
		15:14	Unused		n/a	
27	91	15:0	SLPSWRPM	Slope Switch rpm for dual slope mode	0	0
28	92	15:0	Reserved	Allegro Reserved - Locked	n/a	n/a
29	93	7:0	IPDRMP	Duty Ramp for IPD-T	10 ms	9
		15:8	STRTF	Frequency for 1-cycle startup Mode	1 Hz	16
30	94	15:0	Reserved	Allegro Reserved – Must be Set to Zero	0	0
31	95	15:0	Reserved	Allegro Reserved - Locked	n/a	n/a

SERIAL PORT CONTROL OPTION

Normally the IC is controlled by duty cycle input and uses the EEPROM data that is stored to create the speed curve profile. However, it is possible to use direct serial port control to avoid programming EEPROM.

When using direct control, the input duty cycle command is replaced by writing a 9-bit number to register 165.

Example:

REGADDR[data]: (in decimal)

165[511] → Duty = 100%

165[102] → Duty = $102 / 511 = 20\%$

Upon power up, the IC defaults to duty cycle input mode. To use serial port mode, the internal registers should be programmed before turning the part on. The sequence to use serial port mode is:

1. Drive FG and SPD pins low *
2. Power-up IC
3. Program registers for parameter setting that correspond to each of the EEPROM memory locations.
 - A. REGADDR = 64 + EEPROM ADDR.
 - B. Program register addresses 72 to 94 corresponding to EEPROM addresses 8 to 30.
 - C. It may be helpful to use the GUI text file to help define the hex data for each of the EEPROM addresses.
4. Write to register 165 to start motor

* Note: If SPD is not driven low before power up, motor will try to start immediately as the default high value will demand 100% on signal.

I²C Control Registers

REG	Bits		Function	Description
165	[8:0]	r/w	Speed Demand Input	Duty (%) = code / 511
128	[8:0]	r	Duty applied	Actual demand to the motor windings
138	[7:0]	r	Die temp	Temp °C = 3 + (CODE – 133) / 2
144	[15:0]	r/w	Number of startup failures	Cleared by writing zero or powerup
145	[15:0]	r/w	Number of startup attempts	Cleared by writing zero or powerup
147	[9:0]		Fault Status	
	0	r	Low-side VDS A	
	1	r	Low-side VDS B	
	2	r	Low-side VDS C	
	3	r	High-side VDS A	
	4	r	High-side VDS B	
	5	r	High-side VDS C	
	6	r	TSD	
	7	r	Charge Pump UVLO	
	8	r	VBB UVLO	
	9	r	VBB Overvoltage	
148	[15:0]		Lock detect criteria	
	0	r	Switch Over Error	
	1	r	Too Slow	
	2	r	Too Fast	
	3	r	Out of Sync	
	4	r	Bad Acceleration	
	5	r	Windmill Error	
	6	r	Max Phase Advance	
	14:7		Unused	
	15	w	Clear	Write 1 to clear the latched faults

Serial Port

The A5947 uses standard fast mode I²C serial port format to program the EEPROM or to control the IC speed serially. The serial port can be used for startup configuration, fault readback, direction control, or input duty request. The SPD pin functions as the clock (SCL) input, and the FG pin is the data line (SDA). No special sequence is needed to begin transferring data. If the motor is running, the FG may pull then data line low while trying to initialize into serial port mode. Once an I²C command is received, the SPD input is ignored, and the motor will turn off as if a PWM duty command of 0% was sent.

The A5947 7-bit slave address is 0x55.

I²C Timing Diagrams

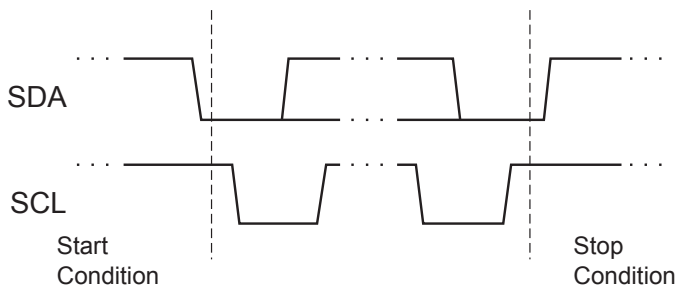

Figure 6: Start and Stop Conditions

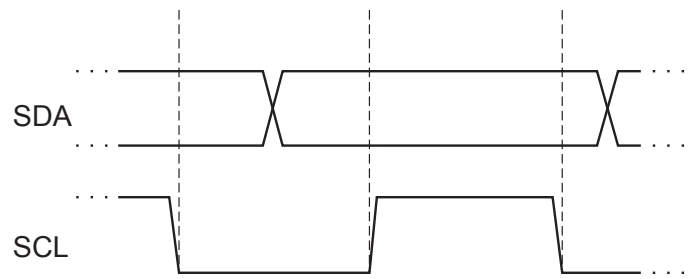

Figure 7: Clock and Data Bit Synchronization

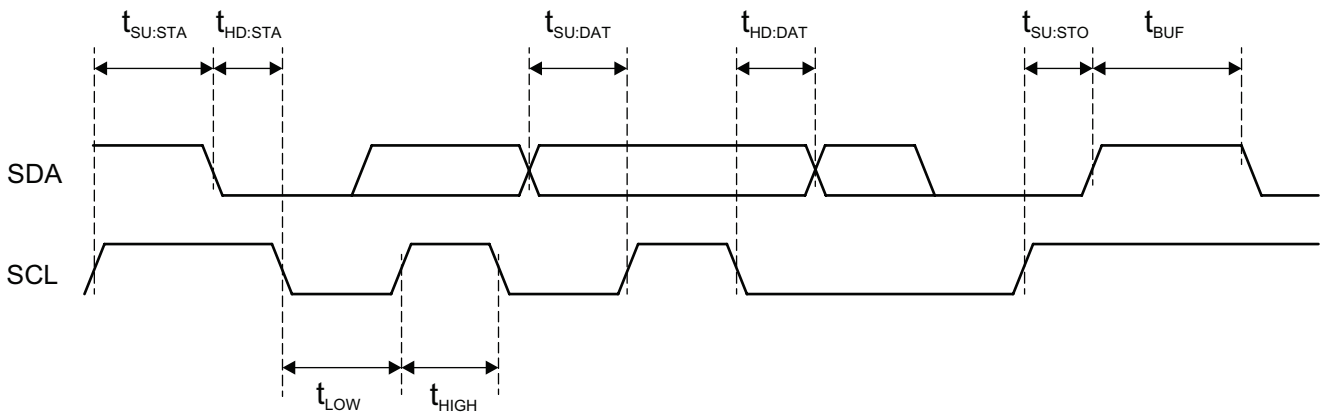

Figure 8: I²C-Compatible Timing Requirements

Write Command

1. Start Condition
2. 7-bit I²C Slave Address (Device ID) 1010101, R/W Bit = 0
3. Internal Register Address
4. 2 data bytes, MSB first
5. Stop Condition

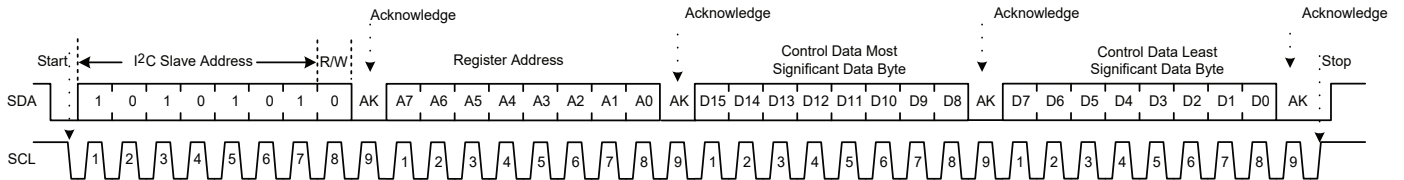

Figure 9: Write Command

Read Command

1. Start Condition
2. 7-bit I²C Slave Address (Device ID) 1010101, R/W Bit = 0
3. Internal Register Address to be read
4. Stop Condition
5. Start Condition
6. 7-bit I²C Slave Address (Device ID) 1010101, R/W Bit = 1
7. Read 2 data bytes
8. Stop Condition

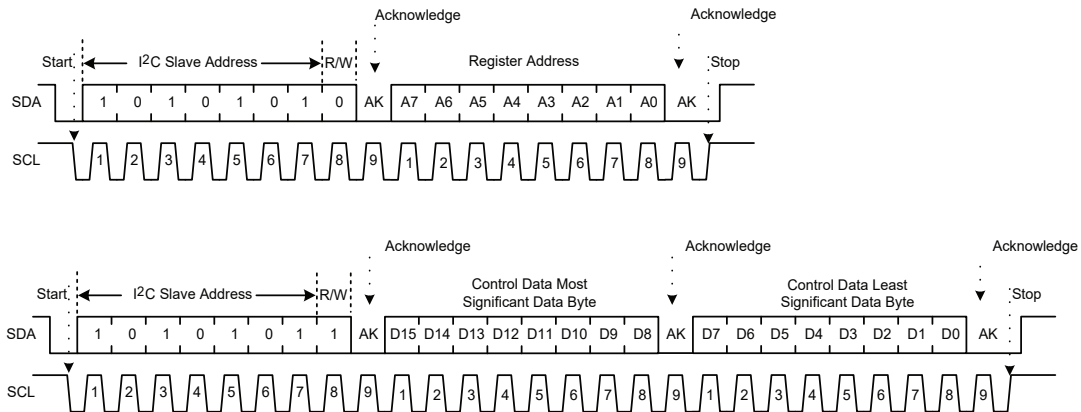

Figure 10: Read Command

Programming EEPROM

The A5947 contains 32 words of 16-bit length. The EEPROM is controlled with the following I²C registers. Refer to application note for EEPROM definition.

Table 1: EEPROM Control – Register 161 (Used to control programming of EEPROM)

15	14	13	12	11	10	9	8	7	6	5	4	3	2	1	0
0	0	0	0	0	0	0	0	0	0	0	0	RD	WR	ER	EN
Bit	Name	Description													
0	EN	Set EEPROM voltage required for writing or erasing													
1	ER	Sets mode to erase													
2	WR	Sets mode to write													
3	RD	Sets mode to read													
15:4	n/a	Do not use; always set to zero during programming process													

Table 2: EEPROM Address – Register 162 (Used to set the EEPROM address to be altered)

15	14	13	12	11	10	9	8	7	6	5	4	3	2	1	0
0	0	0	0	0	0	0	0	0	0	0	eeADDRESS				
Bit	Name	Description													
4:0	eeADDRESS	Used to specify EEPROM address to be changed.													
15:5	n/a	Do not use; always set to zero during programming process													

Table 3: EEPROM DataIn – Register 163 (Used to set the EEPROM new data to be programmed)

15	14	13	12	11	10	9	8	7	6	5	4	3	2	1	0
eeDATAIn															
Bit	Name	Description													
15:0	eeDATAIn	Used to specify the new EEPROM data to be changed													

Table 4: DataOUT – Register 164 (Used for read operations)

15	14	13	12	11	10	9	8	7	6	5	4	3	2	1	0
eeDATAout															
Bit	Name	Description													
15:0	eeDATAout	Used to readback EEPROM data from address defined in register 162													

There are 3 basic commands: Read, Erase, and Write. To change the contents of a memory location, the word must be first erased. The EEPROM programming process (writing or erasing) takes 12 ms per word.

Each word must be written individually.

Example #1: Write EEPROM address 5 to 261 (0x0105)

- 1) Erase the word
 - I²C Write REGADDR[Data] ; comment
 - a. 162[5] ; set EEPROM address to erase
 - b. 163[0] ; set 0000 as Data In
 - c. 161[3] ; set control to Erase and Voltage High
 - d. Wait 12 ms ; requires 12 ms High Voltage Pulse to Write
- 2) Write the new data
 - a. 162[5] ; set EEPROM address to write
 - b. 163[261] ; set Data In = 261
 - c. 161[5] ; set control to Write and Set Voltage High
 - d. Wait 12 ms ; requires 12 ms High Voltage Pulse to Write

Example #2: Read EEPROM address 5 to confirm correct data properly programmed

- 1) Read the word
 - a. 5[I²C Read] ; set EEPROM address to read

PIN DIAGRAMS

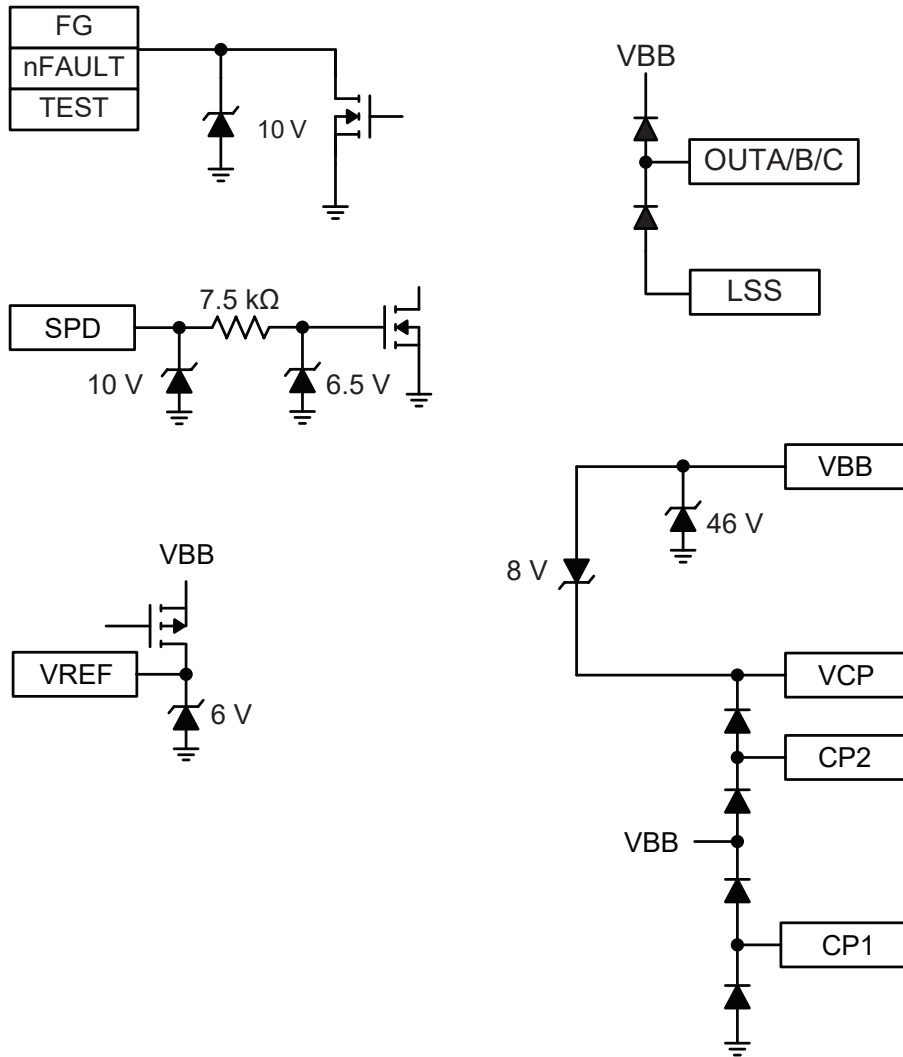

Figure 11: Pin Diagrams

PACKAGE OUTLINE DRAWING

For Reference Only – Not for Tooling Use

(Reference JEDEC MO-153ACT; Allegro DWG-0000379, Rev. 3)
 NOT TO SCALE
 Dimensions in millimeters
 Dimensions exclusive of mold flash, gate burrs, and dambar protrusions
 Exact case and lead configuration at supplier discretion within limits shown

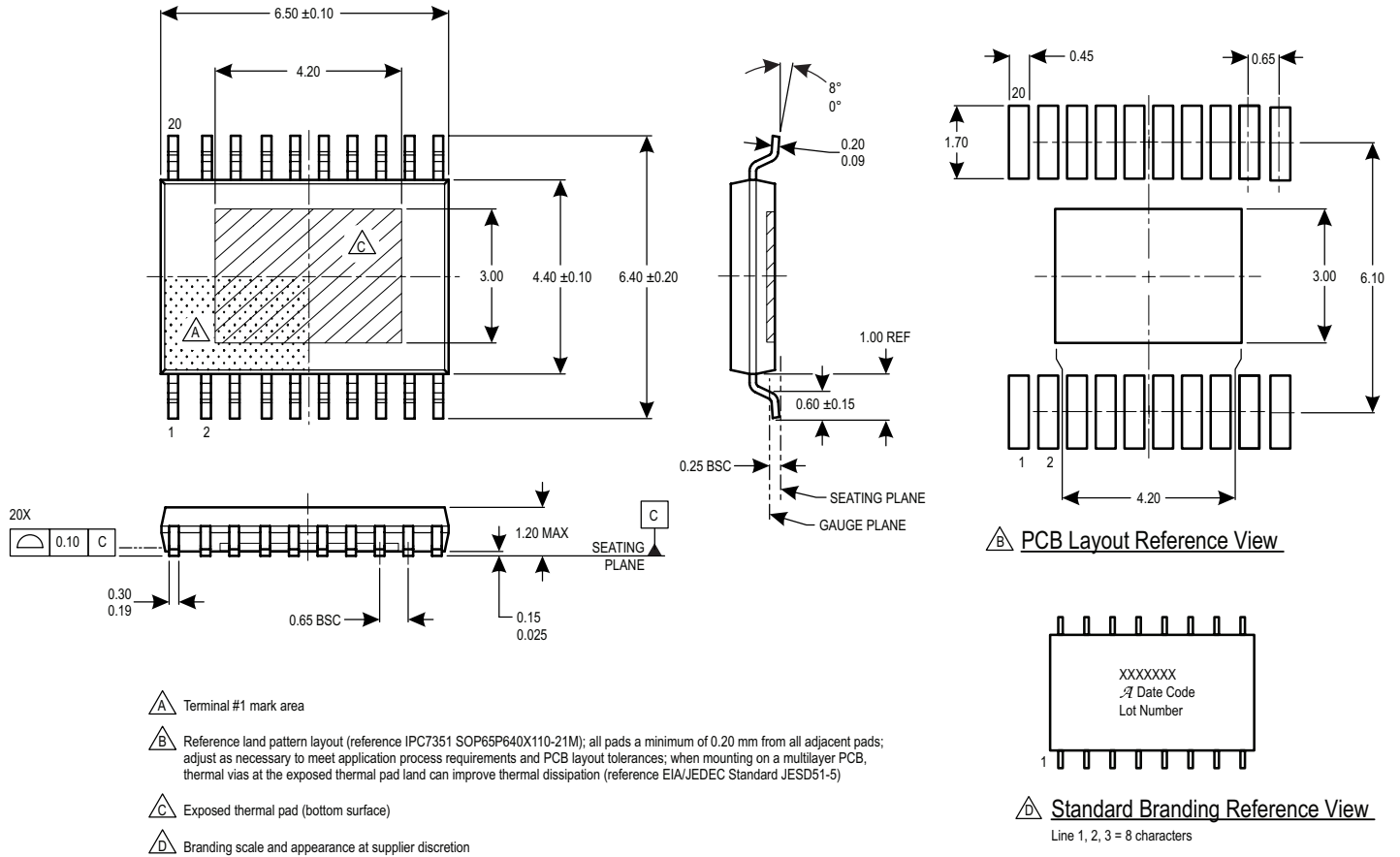

Figure 12: Package LP, 20-Lead TSSOP with Exposed Pad

Revision History

Number	Date	Description
–	May 13, 2021	Initial release
1	July 23, 2021	Removed ET package
2	April 7, 2022	Updated Motor PWM Frequency and Speed Setpoint (page 4); updated package drawing (page 20)

Copyright 2022, Allegro MicroSystems.

Allegro MicroSystems reserves the right to make, from time to time, such departures from the detail specifications as may be required to permit improvements in the performance, reliability, or manufacturability of its products. Before placing an order, the user is cautioned to verify that the information being relied upon is current.

Allegro's products are not to be used in any devices or systems, including but not limited to life support devices or systems, in which a failure of Allegro's product can reasonably be expected to cause bodily harm.

The information included herein is believed to be accurate and reliable. However, Allegro MicroSystems assumes no responsibility for its use; nor for any infringement of patents or other rights of third parties which may result from its use.

Copies of this document are considered uncontrolled documents.

For the latest version of this document, visit our website:

www.allegromicro.com

Mouser Electronics

Authorized Distributor

Click to View Pricing, Inventory, Delivery & Lifecycle Information:

[Allegro MicroSystems:](#)

[A5947KLPTR-B-T](#)