

Part List

6V DC motor(13000 rpm $\pm 14\%$) x2

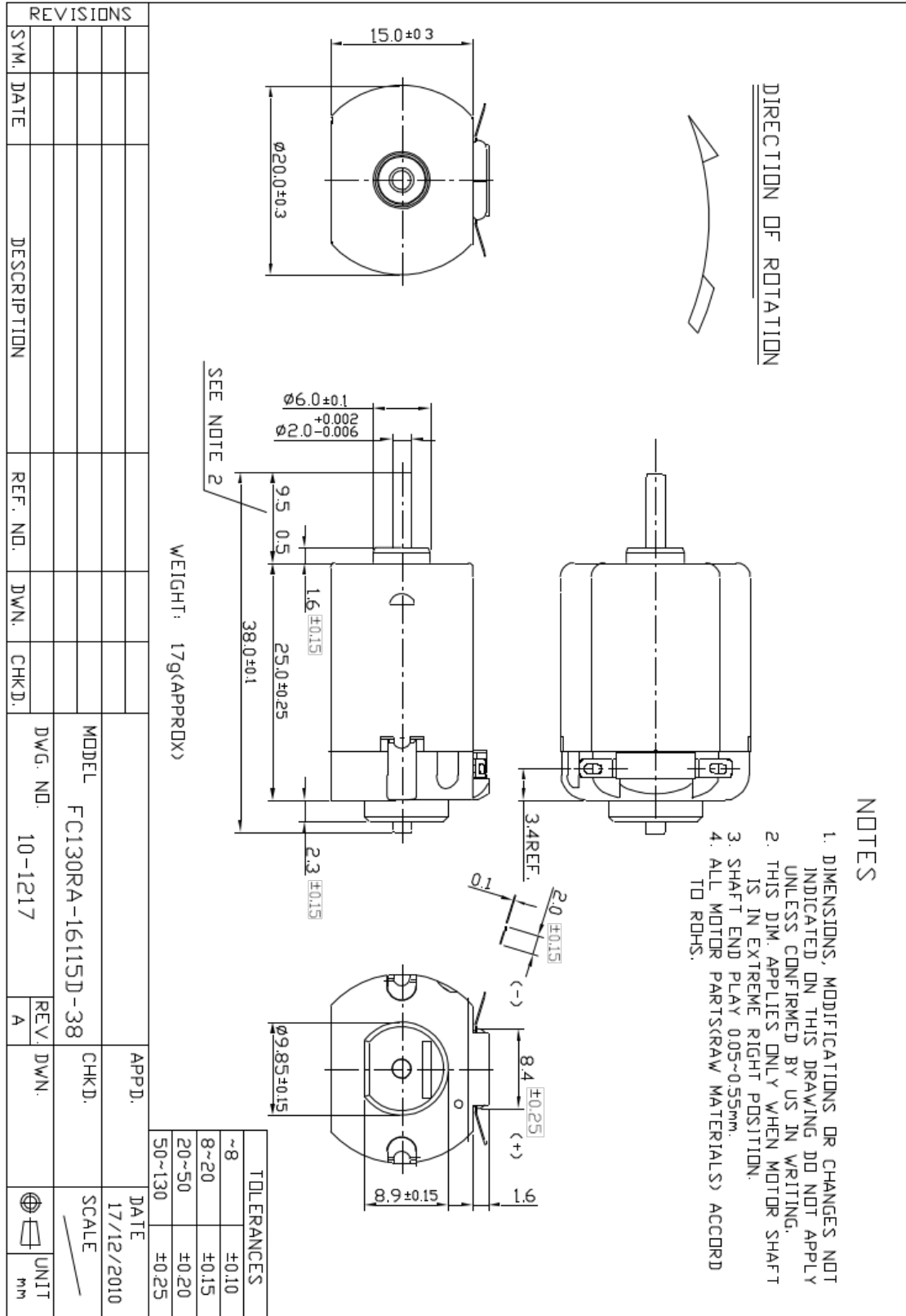

- *Small stepper motor x1*

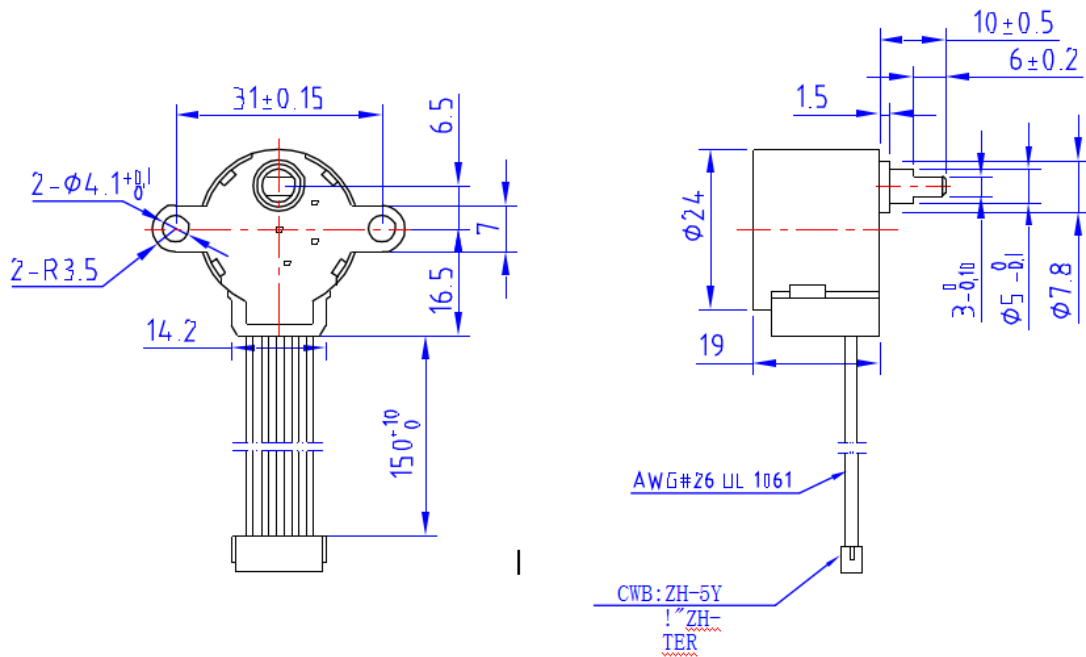

- *Standard servo x1 (Speed: 0.17/60°@4.8V; 0.14/60°@6.0V)
(Torque: 3.5kg.cm@4.8V; 4.8kg.cm@6.0V)*
- *Micro servo x1 (Speed: 0.12/60°@4.8V; 0.10/60°@6.0V)
(Torque: 1.5kg.cm@4.8V; 1.8kg.cm@6.0V)*