

Actual size:  
2.28 x 2.4 x 0.5in  
57,9 x 61,0 x 12,7mm



## Ripple Attenuator Module

### Features & Benefits

- Reduces output PARD to  $\leq 10\text{mVp-p}$
- Full attenuation up to 20A load
- No adjustments required
- Compatible with all MI-Family converters from 5 to  $50\text{V}_{\text{DC}}$  output
- Efficiency: 93% – 99%
- Converter sense, trim, OVP & OCP retained
- MIL-STD-810 environments
- Size: 2.28" x 2.4" x 0.5"  
(57,9 x 61,0 x 12,7mm)

### Product Highlights

The MI-RAM is designed for applications where extremely low noise outputs are required. When used with any Vicor MI-Family DC-DC converter, the MI-RAM reduces both line frequency related ripple and switching noise to less than or equal to  $10\text{mVp-p}$ , DC to 20MHz.

The combination of the MI-RAM with an MI-Family converter provides the output noise performance of a linear supply at a power density in excess of  $15\text{W/in}^3$ .

All of the features of the MI-Family converter remain available while using the MI-RAM, including output voltage trimming, OVP and OTP (MI-200 only), current limiting, remote sense, and output inhibit.

Full encapsulation in a low profile package enables the MI-RAM to meet MIL-STD-810 environmental testing requirements.

### Packaging Options

- Standard:** Slotted baseplate
- SlimMod:** Flangeless baseplate, option suffix: - S  
*Example:* MI - RAM - M1 - S
- FinMod:** Finned heat sink, option suffix:  
- F1, - F2, -F3 or -F4  
*Examples:*  
MI - RAM - M1 -F1, 0.25" fins, longitudinal  
MI - RAM - M1 -F2, 0.50" fins, longitudinal  
MI - RAM - M1 -F3, 0.25" fins, transverse  
MI - RAM - M1 -F4, 0.50" fins, transverse

### Electrical Considerations

**Transient Response and Dynamic Range:** Full rated noise attenuation will be maintained at the MI-RAM output for step load changes up to 10% of the rated output current of the source converter, with the MI-RAM exhibiting an underdamped output excursion of less than  $10\text{mVp-p}$ . Some degradation in noise attenuation during the transient response period following the step may be exhibited for larger load changes. Adding output capacitance to the MI-RAM will improve the rejection over a larger dynamic range.

**Sense Connection:** Sense-in and sense-out connections are provided on the MI-RAM. Sense-in connections must be connected to the corresponding sense connections on the Vicor converter. Sense-out pins on the MI-RAM must be connected between the MI-RAM power-output pins, and the point of load.

**Output Load Characteristics:** When used in combination with Vicor DC-DC converters, and with sense leads connected, the MI-RAM will be stable for any non-inductive load.

**DC Voltage Drop:** Below full load, the input to output DC Voltage Drop is controlled to be an essentially constant voltage which appears between the -IN and -OUT terminals. In overload the DC voltage drop will rise as current increases. A few tens of millivolts appears between the +IN and +OUT terminals. Care should be taken not to connect IN and OUT terminals (i.e. through scope probe returns, grounds, etc.), as attenuation will be adversely affected.

### Part Numbering

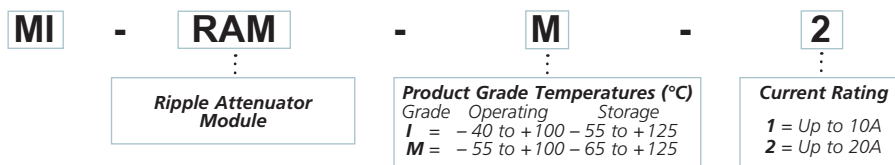

## Specifications

(typical at  $T_{BP} = 25^{\circ}\text{C}$ , nominal line and 75% load, unless otherwise specified)

Parameter	Min.	Typ.	Max.	Units	Notes
Output noise and ripple		2.0	3.0	mVp-p	MI-200; 10% to 100% load
		6.0	10.0	mVp-p	MI-J00; 10% to 100% load
Input voltage range	5.0		50	$V_{DC}$	
Output voltage accuracy	99.5		100.5	%	Of MI source converter
Full load current			10	A	MI-RAM-I1 and MI-RAM-M1
			20	A	MI-RAM-I2 and MI-RAM-M2
DC voltage drop	0.34		0.38		10% to full load
Dissipation = (DC voltage drop x load current) + ( $V_{IN}$ x 15mA)					
Isolation		250		$V_{RMS}$	Input / output to baseplate
Weight	3.6	3.7	3.8	ounces	
	102	105	107	grams	

## PRODUCT GRADE SPECIFICATIONS

Parameter	I-Grade	M-Grade
Storage temperature	-55°C to +125°C	-65°C to +125°C
Operating temperature (baseplate)	-40°C to +100°C	-55°C to +100°C
Power cycling burn-in	12 hours, 29 cycles	96 hours, 213 cycles
Temperature cycled with power off	12 cycles	12 cycles
17°C per minute rate of change	-65°C to +100°C	-65°C to +100°C
Test data supplied at these temperatures <sup>[a]</sup>	-40°C, +80°C	-55°C, +80°C
Warranty	2 years	2 years
Environmental compliance	MIL-STD-810	MIL-STD-810
Derating	NAVMAT P-4855-1A	NAVMAT P-4855-1A

<sup>[a]</sup> Test data available for review or download from vicorpower.com

## ENVIRONMENTAL QUALIFICATIONS

Parameter	Qualification
Altitude	MIL-STD-810D, Method 500.2, Procedure III, explosive decompression (40K ft.).
	MIL-STD-810D, Method 500.2, Procedure II, 40,000ft., 1000 – 1500ft./min. to 70,000ft., unit functioning
Explosive Atmosphere	MIL-STD-810C, Method 511.1, Procedure I
Vibration	MIL-STD-810D, Method 514.3, Procedure I, category 6, helicopter, 20g
	MIL-STD-810D, Method 514.3 random: 10 – 300Hz @ 0.02g <sup>2</sup> /Hz, 2000Hz @ 0.002g <sup>2</sup> /Hz, 3.9 total Grms 3hrs/axis. Sine: 30Hz @ 20g, 60Hz @ 10g, 90Hz @ 6.6g, 120Hz @ 5.0g, 16.0 total Grms, 3 axes
	MIL-STD-810E, Method 514.4, Table 514.4-VII, ±6 db/octave, 7.7Grms, 1hr/axis
Shock	MIL-STD-810D, Method 516.3, Procedure I, functional shock, 40g
	MIL-STD-202F, Method 213B, 18 pulses, 60g, 9msec
	MIL-STD-202F, Method 213B, 75g, 11ms saw tooth shock
	MIL-STD-202F, Method 207A, 3 impacts / axis, 1, 3, 5 feet
Acceleration	MIL-STD-810D, Method 513.3, Procedure II Operational test, 9g for 1 minute along 3 mutually perpendicular axes
Humidity	MIL-STD-810D, Method 507.2, Procedure I, cycle I, 240 hrs, 88% relative humidity
Solder Test	MIL-STD-202, Method 208, 8hr. aging
Fungus	MIL-STD-810C, Method 508.1
Salt-Fog	MIL-STD-810C, Method 509.1

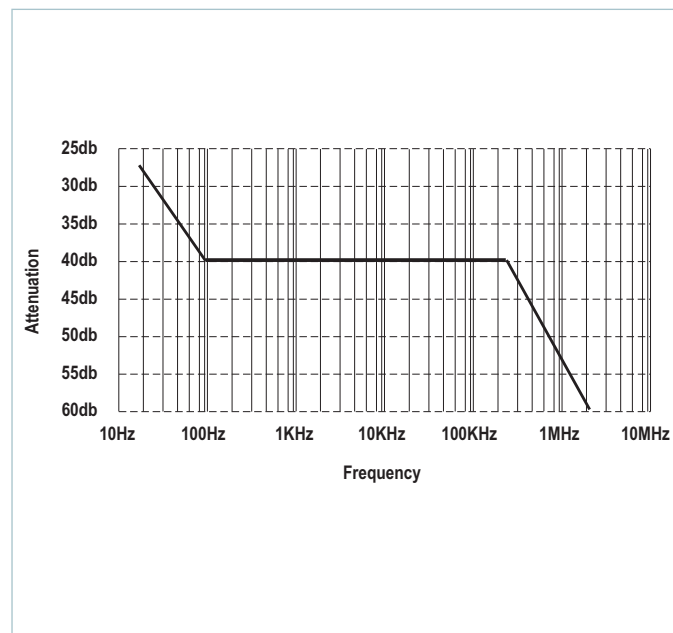
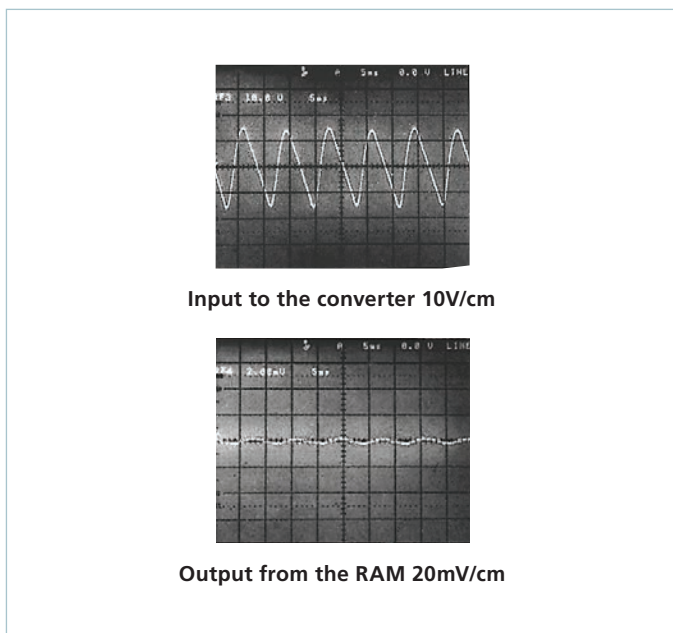

Figure 1 — Comparison of input to output ripple (typical)

Figure 2 — Attenuation vs. frequency (typical)

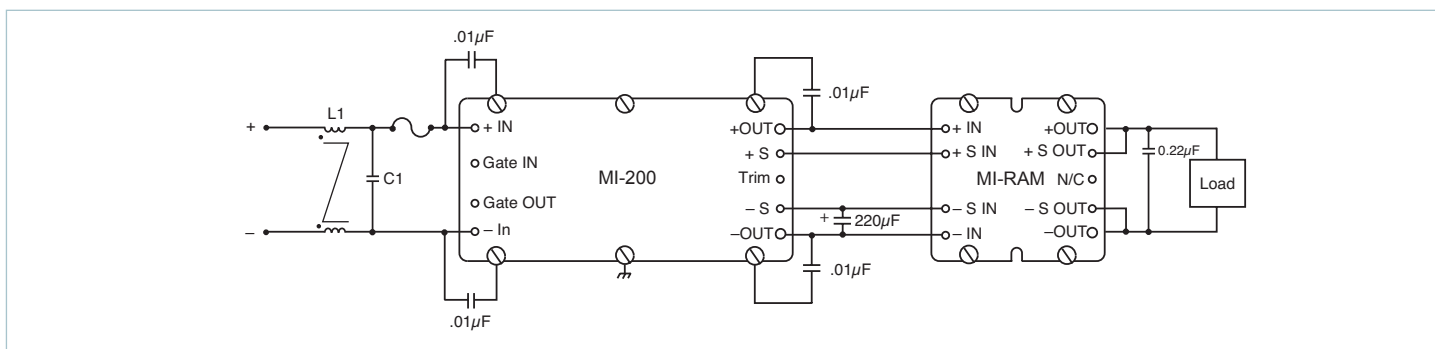
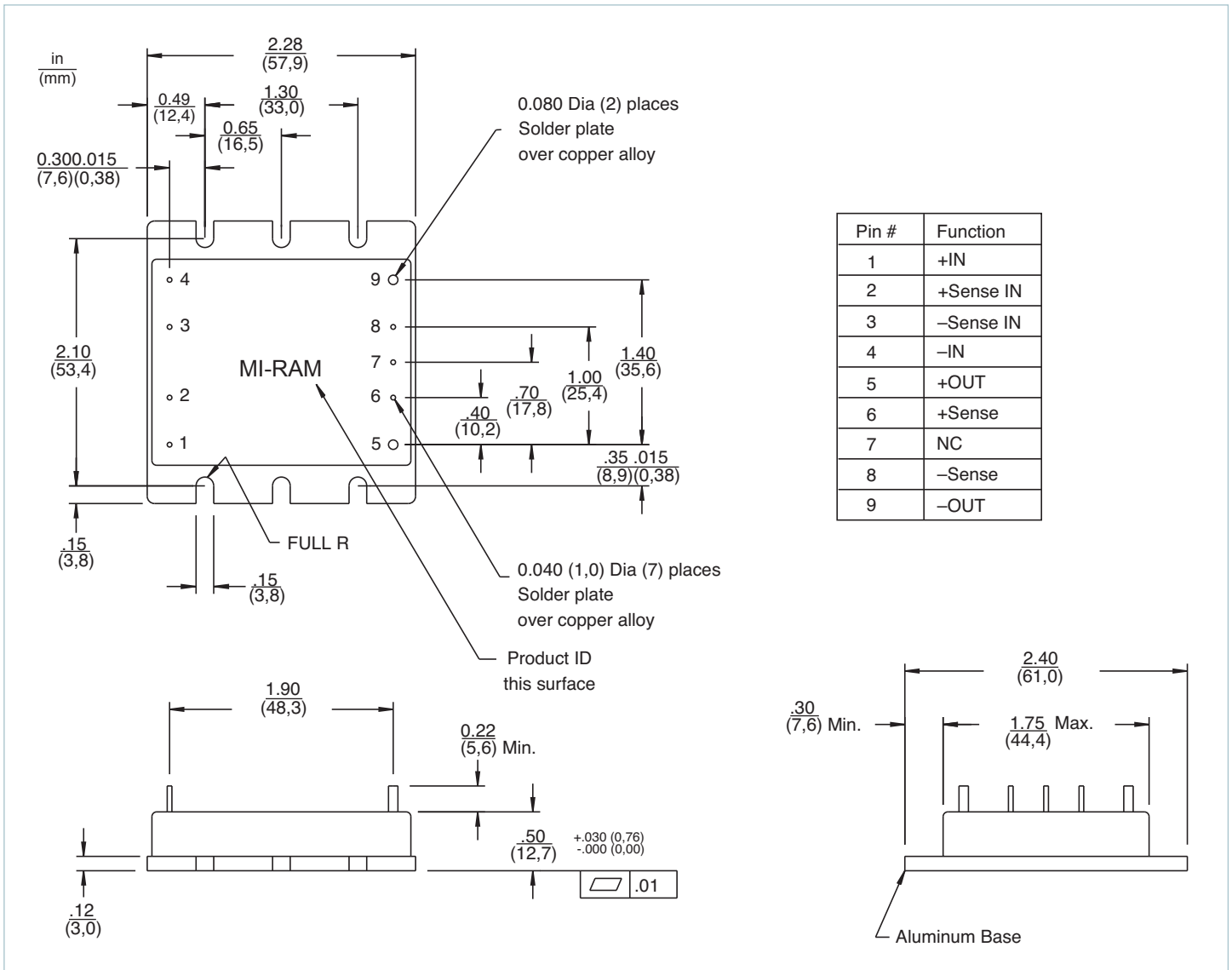

Figure 3 — Connection diagram

### Storage

Vicor products, when not installed in customer units, should be stored in ESD safe packaging in accordance with ANSI/ESD S20.20, "Protection of Electrical and Electronic Parts, Assemblies and Equipment" and should be maintained in a temperature controlled factory/warehouse environment not exposed to outside elements controlled between the temperature ranges of 15°C and 38°C. Humidity shall not be condensing, no minimum humidity when stored in an ESD compliant package.

Mechanical Drawing



---

**Vicor's comprehensive line of power solutions includes high density AC-DC and DC-DC modules and accessory components, fully configurable AC-DC and DC-DC power supplies, and complete custom power systems.**

Information furnished by Vicor is believed to be accurate and reliable. However, no responsibility is assumed by Vicor for its use. Vicor makes no representations or warranties with respect to the accuracy or completeness of the contents of this publication. Vicor reserves the right to make changes to any products, specifications, and product descriptions at any time without notice. Information published by Vicor has been checked and is believed to be accurate at the time it was printed; however, Vicor assumes no responsibility for inaccuracies. Testing and other quality controls are used to the extent Vicor deems necessary to support Vicor's product warranty. Except where mandated by government requirements, testing of all parameters of each product is not necessarily performed.

**Specifications are subject to change without notice.**

Visit [http://www.vicorpower.com/mil-cots\\_dc-dc/mil-cots\\_mi-ram\\_ripple\\_attenuator\\_module](http://www.vicorpower.com/mil-cots_dc-dc/mil-cots_mi-ram_ripple_attenuator_module) for the latest product information.

### **Vicor's Standard Terms and Conditions and Product Warranty**

All sales are subject to Vicor's Standard Terms and Conditions of Sale, and Product Warranty which are available on Vicor's webpage (<http://www.vicorpower.com/termsconditionswarranty>) or upon request.

### **Life Support Policy**

VICOR'S PRODUCTS ARE NOT AUTHORIZED FOR USE AS CRITICAL COMPONENTS IN LIFE SUPPORT DEVICES OR SYSTEMS WITHOUT THE EXPRESS PRIOR WRITTEN APPROVAL OF THE CHIEF EXECUTIVE OFFICER AND GENERAL COUNSEL OF VICOR CORPORATION. As used herein, life support devices or systems are devices which (a) are intended for surgical implant into the body, or (b) support or sustain life and whose failure to perform when properly used in accordance with instructions for use provided in the labeling can be reasonably expected to result in a significant injury to the user. A critical component is any component in a life support device or system whose failure to perform can be reasonably expected to cause the failure of the life support device or system or to affect its safety or effectiveness. Per Vicor Terms and Conditions of Sale, the user of Vicor products and components in life support applications assumes all risks of such use and indemnifies Vicor against all liability and damages.

### **Intellectual Property Notice**

Vicor and its subsidiaries own Intellectual Property (including issued U.S. and Foreign Patents and pending patent applications) relating to the products described in this data sheet. No license, whether express, implied, or arising by estoppel or otherwise, to any intellectual property rights is granted by this document. Interested parties should contact Vicor's Intellectual Property Department.

#### **Vicor Corporation**

25 Frontage Road  
Andover, MA, USA 01810  
Tel: 800-735-6200  
Fax: 978-475-6715

#### **email**

Customer Service: [custserv@vicorpower.com](mailto:custserv@vicorpower.com)  
Technical Support: [apps@vicorpower.com](mailto:apps@vicorpower.com)

# Mouser Electronics

Authorized Distributor

Click to View Pricing, Inventory, Delivery & Lifecycle Information:

[Vicor:](#)

[MI-RAM-M1](#) [MI-RAM-I1](#) [MI-RAM-I1-B1](#) [MI-RAM-I2](#) [MI-RAM-I2-B1](#) [MI-RAM-I2-F2](#) [MI-RAM-M1-B1](#) [MI-RAM-M1-S](#)  
[MI-RAM-M2](#)