

MS Series Remote Control Encoder and Decoder



The MS Series encoders and decoders are ideal for one-way remote control applications. They are used to transfer the status of up to eight buttons or contacts across a wireless or wired link. The large, twenty-four bit address size makes transmissions highly unique, minimizing the possibility of conflict between multiple devices. The encoders and decoders are configured through a simple hardware interface, so no programming or software is required.

Encoder/Decoder Configuration: The MS Series is configured by connecting pins to supply or ground. There is no software or programming required.

Unique Addressing: The MS Series offers a simple hardware addressing method without the need for software or programming. A 24-bit address is created in the encoder by pressing and holding a button. The address is learned by the decoder with another button press. The 24-bit address provides over 16.7 million addresses, so the chances of adjacent systems activating each other is very small.

More Buttons: The MS Series supports up to 8 data lines that can be connected to buttons, contacts or microcontroller lines. This offers more functionality than many similar parts. Additionally, the outputs can be set as latched or momentary by setting the logic state of a single pin.

Control Permissions: The MS Series can be configured so that certain encoders can only activate certain outputs on the decoder. This allows the creation of user groups and relationships rather than an all-or-nothing activation.

Receiver Power Control: The decoder can power the receiver on a 10% duty cycle. This allows the receiver to stay asleep 90% of the time, conserving power consumption in applications where power is critical. Likewise, the encoder can power on the transmitter only when it is sending data.

Transmitter Identification: The decoder outputs a binary number identifying the encoder that sent the transmission. This allows access attempts to be logged.

Low Power: The MS Series has extremely low power consumption, making it ideal for applications with a limited power supply, such as a coin cell battery.

Development System: The MS Series Master Development System allows customers to easily evaluate the performance and operation of the MS Series. The Development System features an encoder paired with a Linx LR Series Transmitter on the sending side and a decoder and paired with a Linx LR Series Receiver on the receive side. The boards are fully assembled and feature a prototyping area with full access to all of the lines for the encoder and decoder. This makes it very simple to interface the Development System to prototype circuits to test operation.

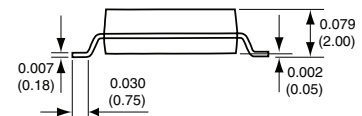
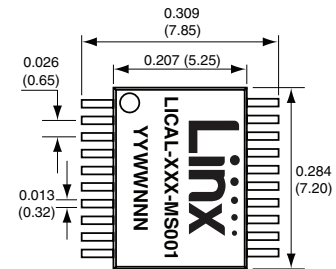

Specifications	
Operating Voltage	2.0 to 5.5VDC
Supply Current	370µA
Power Down Current	0.1µA
Response Time	22.5ms
Operating Temperature Range	-40 to +85°C

Applications

- Door and Gate Openers
- Remote Device Control
- Call Systems
- Home / Industrial Automation
- Remote Status Monitoring
- Lighting Control

Typical Application Circuits

When activated, the encoder encodes the current states of its inputs and its address into a packet and outputs a digital data stream. This data can be sent to a decoder by RF modules, infrared link or even a wire. The decoder checks the received packet to make sure there are no errors and that the received address has been learned. If everything is good, then the decoder replicates the encoder's input states on its outputs. These outputs are connected to whatever circuitry is required by the application.

The circuits below show typical applications of the MS Series encoder and decoder.

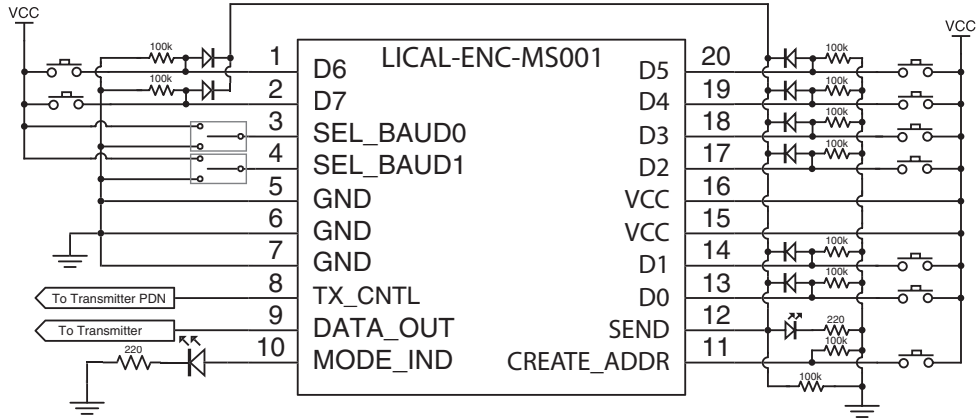

MS Series encoder

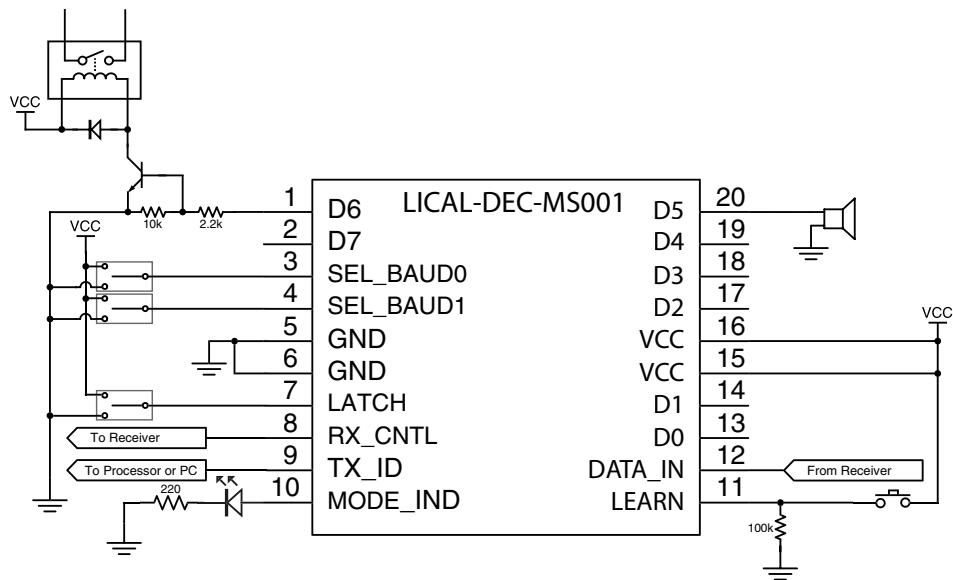

MS Series decoder

Ordering Information

Part Number	Description
LICAL-ENC-MS001	MS Series Encoder
LICAL-DEC-MS001	MS Series Decoder
MDEV-LICAL-MS	MS Series Master Development System with LR Series Modules
MDEV-LICAL-MS-ES	MS Series Master Development System With ES Series modules

Mouser Electronics

Authorized Distributor

Click to View Pricing, Inventory, Delivery & Lifecycle Information:

[TE Connectivity:](#)

[LICAL-ENC-MS001](#)