

REVISIONS			
REV	DESCRIPTION	DATE	APPROVED
A	ECO #4059	04/05/01	A.M.
B	ECO #6854	09/26/07	A.D.M.

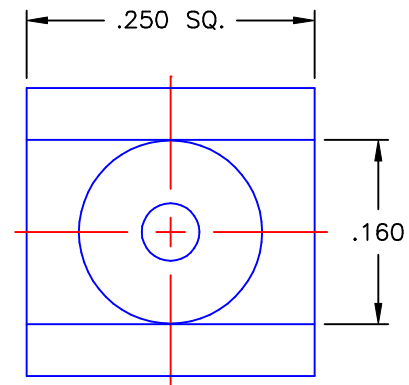

PROPRIETARY INFORMATION
NOT TO BE RELEASED
WITHOUT WRITTEN PERMISSION
FROM AN AUTHORIZED
REPRESENTATIVE OF
APPLIED ENGINEERING PRODUCTS

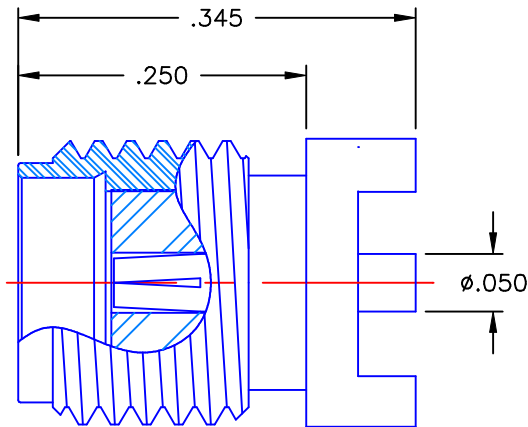
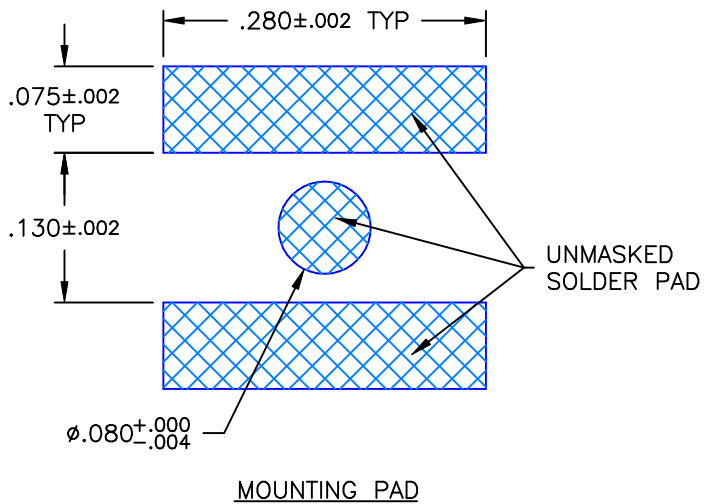

NOTES:

MATERIALS:

1. BODY = STAINLESS STEEL PER ASTM A582, ALLOY 303, CONDITION "A".
2. INSULATOR = VIRGIN WHITE TEFLON PER ASTM D1710, GRADE 1, TYPE I, CLASS "A".
3. CONTACT = BERYLLIUM COPPER PER ASTM B196, ALLOY C17300, TEMPER TD04.

FINISHES:

1. BODY = GOLD PLATE PER MIL-G-45204, TYPE II, CLASS 0, GRADE C, OVER .000050 TO .00010 STRESS FREE NICKEL PER QQ-N-290.
2. CONTACT = GOLD PLATE PER MIL-G-45204, TYPE II, CLASS 1, GRADE C, OVER .00010 TO .00020 STRESS FREE SULFAMATE NICKEL PER QQ-N-290.

UNLESS OTHERWISE SPECIFIED DIMENSIONS ARE IN INCHES TOLERANCES ON	DWN: DATE	 APPLIED ENGINEERING PRODUCTS 104 John W. Murphy Dr. New Haven, CT 06513	SMA STRAIGHT JACK SURFACE MOUNT RECEPTACLE			
	A.M. 04/05/01				a RADIAL company	
DECIMAL	ANGLE	CHKD: DATE	REFERENCE: MATERIALS & FINISHES: SEE NOTES			
		D.N. 04/05/01				
		APVD: DATE	SIZE	FSCM NO.	DWG. NO.	REV
		D.J.C. 04/05/01	A	19505	9650-1113-005	B
ORIGINATOR: A.M. DATE: 04/05/01			SCALE 6:1	THIRD ANGLE PROJECTION	SHEET 1 OF 1	

9650-1113-005

Mouser Electronics

Authorized Distributor

Click to View Pricing, Inventory, Delivery & Lifecycle Information:

Radial:

[9650-1113-005](#)