

NAC/NAM/NAH/NAP series(4-30A)

NAC -10 -472 -□

① ② ③ ④

- ① Series Name
- ② Rated Current
- ③ Line to ground capacitor code: Refer to table 1.1.

table 1.1 Line to ground capacitor code

Code	N A C	N A H	N A P	Leakage Current (Input 125/250V 60Hz)	Line to ground capacitor (nominal value)
000	●	●	●	5 μ A / 10 μ A max	Not Provided
101	●	●	●	12.5 μ A / 25 μ A max	100pF
221	●	●	●	25 μ A / 50 μ A max	220pF
331	●	●	●	37.5 μ A / 75 μ A max	330pF
471	●	●	●	50 μ A / 100 μ A max	470pF
681	●	●	●	75.5 μ A / 150 μ A max	680pF
102	●	●	●	0.13 mA / 0.25mA max	1,000pF
222	●	●	●	0.25 mA / 0.5 mA max	2,200pF
332	●	●	●	0.38 mA / 0.75mA max	3,300pF
472	●	●	●	0.5 mA / 1.0 mA max	4,700pF

* When the line to ground capacitor code is different, the attenuation characteristic is different.

- ④ Option
- D: DIN rail installation type

* The dimensions change when the option is set. Refer to External view.

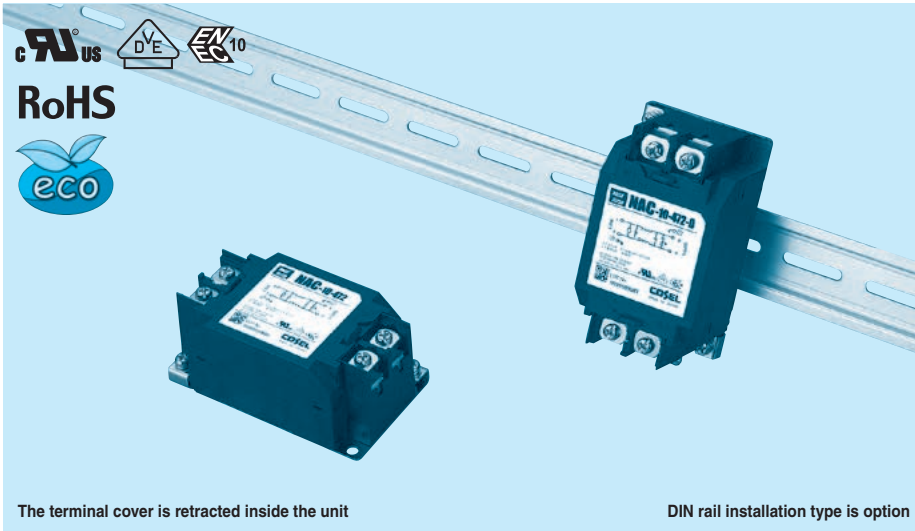

The terminal cover is retracted inside the unit

DIN rail installation type is option

Features of NAC/NAM/NAH/NAP series

- Single Phase 250VAC (1-Stage filter)
 - Quick and easy push-down terminal
- Just connect the wires, push-down and tighten the screws with a screwdriver

- NAC : High-attenuation type from 150kHz to 1MHz
- NAM: Low leakage current type
- NAH: Ultra high-attenuation type from 9kHz to 1MHz
- NAP : Outside impulse high-attenuation type

Specifications

No.	Items	NAC-04-472	NAC-06-472	NAC-10-472	NAC-16-472	NAC-20-472	NAC-30-472
		NAM-04-000	NAM-06-000	NAM-10-000	NAM-16-000	NAM-20-000	NAM-30-000
		-	NAH-06-472	NAH-10-472	NAH-16-472	NAH-20-472	NAH-30-472
		NAP-04-472	NAP-06-472	NAP-10-472	NAP-16-472	NAP-20-472	NAP-30-472
1	Rated Voltage[V]	AC 1 ϕ 250 / DC250					
2	Rated Current[A]	4	6	10	16	20	30
3	Test Voltage (Terminal-Mounting Plate)	2,500 VAC (Cutoff Current = 20mA), 1minute at room temperature and humidity					
4	Isolation Resistance (Terminal-Mounting Plate)	500 VDC 100M Ω min at room temperature and humidity					
5	Leakage current	Refer to table 1.1					
6	Voltage drop	1.0V max					
7	Safety agency approval temperatures	-25 to +85°C (Refer to Derating Curve)					
8	Operating temperature	-40 to +85°C (Refer to Derating Curve)					
9	Operating humidity	20 to 95%RH (Non condensing)					
10	Storage temperature/humidity	-40 to +85°C/20 to 95%RH (Non condensing)					
11	Vibration	10 to 55Hz, 19.6m/s ² (2G), 3min. Period, 1hour each X, Y and Z axis					
12	Impact	196.1m/s ² (20G), 11ms Once each X, Y and Z axis					
13	Safety agency approvals	UL1283, CSA C22.2 No.8 (C-UL), DIN EN60939 VDE0565 Teil3-1, ENEC (At only AC input)					
14	Case size (without projection) /Weight	53 X 41 X 92 mm [2.09 X 1.61 X 3.62 inches] (W X H X D) /300g max (Option : -D refer to external view)					

Circuit Diagram

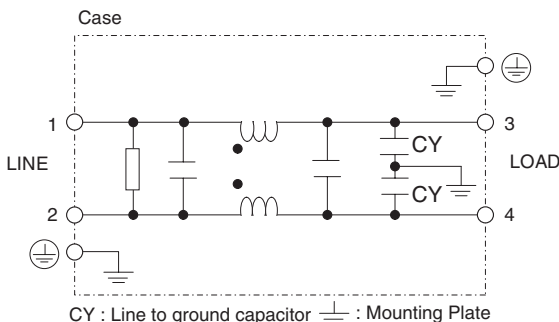

Derating Curve

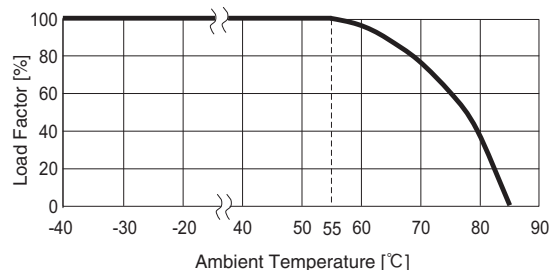

External view

As this product is adopted push-down type terminal block, this appearance is as follows.

- ① The terminal cover is retracted inside the unit.
- ② The screws for connecting the terminals are held in the up right position.

Standard Type

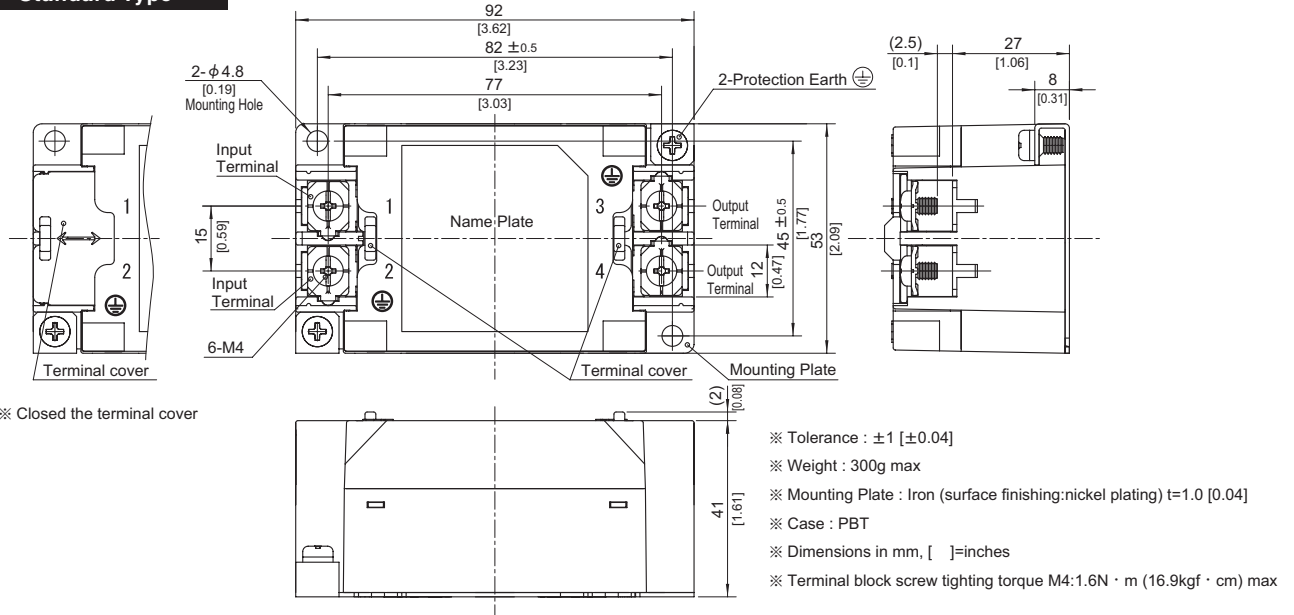

※ Closed the terminal cover

DIN rail installation Type

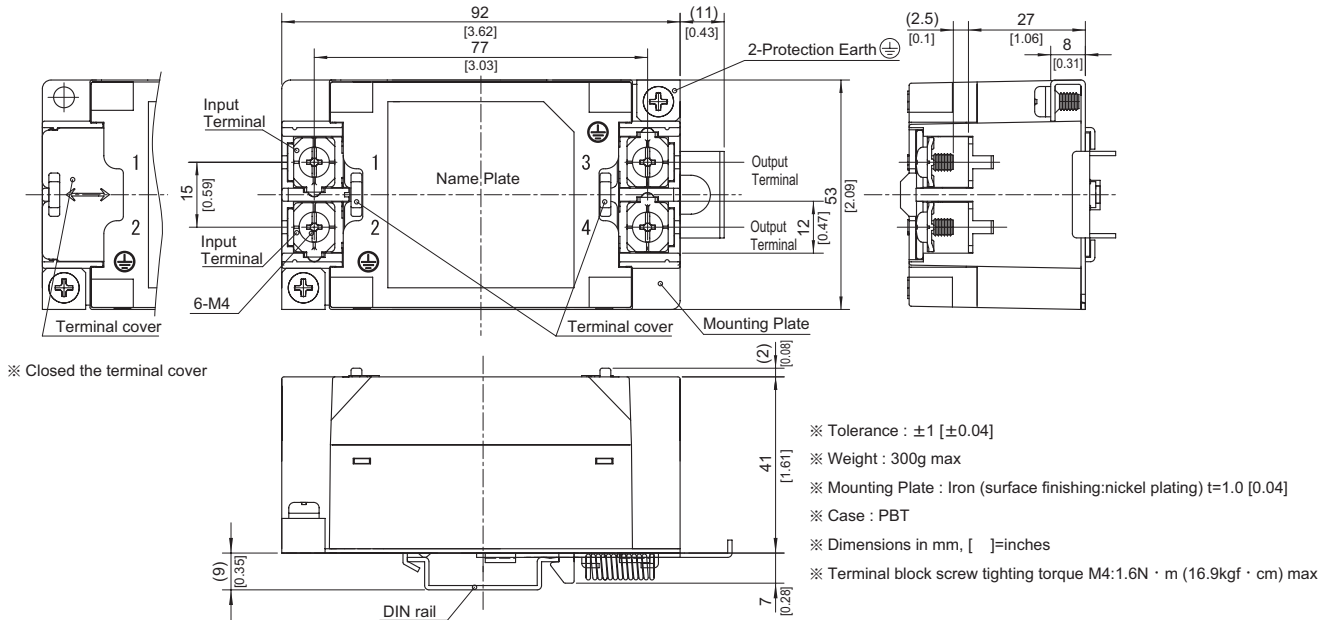

※ Closed the terminal cover

■Note when installing the EMI/EMC Filter on a DIN rail.

When the EMI/EMC Filter is grounded through the DIN rail, the proper noise attenuation may not be achieved.

Be sure to connect the protection earth (PE) of the EMI/EMC Filter body to the earth. It can connect the ground to either one only.

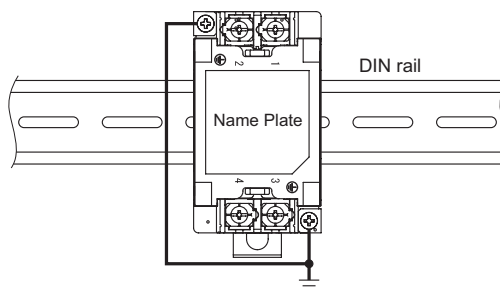

NAC/NAM/NAH/NAP series (40,50,60A)

NAC -50 -472



- ① Series Name
- ② Rated Current
- ③ Line to ground capacitor code: Refer to table 1.1.

table 1.1 Line to ground capacitor code

Code	N A C	N A M	N A H	N A P	Leakage Current (Input 125/250V 60Hz)	Line to ground capacitor (nominal value)
000	●	●	●	●	5 μ A/ 10 μ A max	Not Provided
471	●	●	●	●	50 μ A/100 μ A max	470pF
222	●	●	●	●	0.25 mA/ 0.5 mA max	2,200pF
472	●	●	●	●	0.5 mA/ 1.0 mA max	4,700pF

* When the line to ground capacitor code is different, the attenuation characteristic is different.

Features of NAC/NAM/NAH/NAP series

- Single Phase 277VAC/300VDC (1-stage filter)
This product is available 277VAC equipment in factory switchboards and building equipment
- Withstand voltage 4,000 VAC

- **NAC** : High-attenuation type from 150kHz to 1MHz
- **NAM** : Low leakage current type
- **NAH** : Ultra high-attenuation type from 9kHz to 1MHz
- **NAP** : Outside impulse high-attenuation type

Specifications

No.	Items	NAC-40-472		NAC-50-472		NAC-60-472		
		NAM-40-000		NAM-50-000		NAM-60-000		
		NAH-40-472		NAH-50-472		NAH-60-472		
		NAP-40-472		NAP-50-472		NAP-60-472		
1	Rated Voltage	[VAC]	277 (voltage range:305 max) 1 ϕ 50/60Hz					
		[VDC]	300 (voltage range:400 max)					
2	Rated Current[A]	40		50		60		
3	Test Voltage (Terminal-Mounting Plate)	4,000 VAC (Cutoff Current = 25mA), 1minute at room temperature and humidity						
4	Isolation Resistance (Terminal-Mounting Plate)	500 VDC 100M Ω min at room temperature and humidity						
5	Leakage current	Refer to table 1.1						
6	DC resistance	10m Ω max		6.0m Ω max		4.5m Ω max		
7	Safety agency approval temperatures	-25 to +85°C (Refer to Derating Curve)						
8	Operating temperature	-40 to +85°C (Refer to Derating Curve)						
9	Operating humidity	20 to 95%RH (Non condensing)						
10	Storage temperature/humidity	-40 to +85°C/20 to 95%RH (Non condensing)						
11	Vibration	10 to 55Hz, 19.6m/s ² (2G), 3min. Period, 1hour each X, Y and Z axis						
12	Impact	196.1m/s ² (20G), 11ms Once each X, Y and Z axis						
13	Safety agency approvals	UL60939[Overvoltage Category : III Altitude:3000m], CSA C22.2 No.8 (C-UL) EN60939(DEMKO)[Overvoltage Category: III Altitude:3000m] , ENEC						
14	Case size (without projection) /Weight	65x54x153mm[2.56x2.13x6.02 inches](WxHxD) / 750g max						

Circuit Diagram

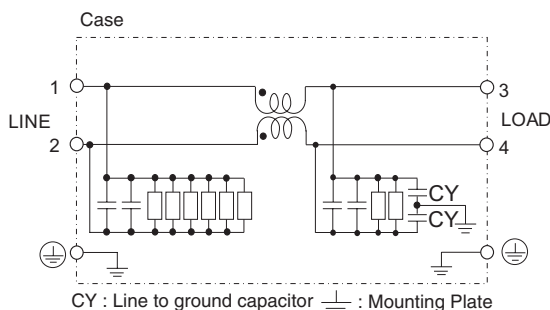

Derating Curve

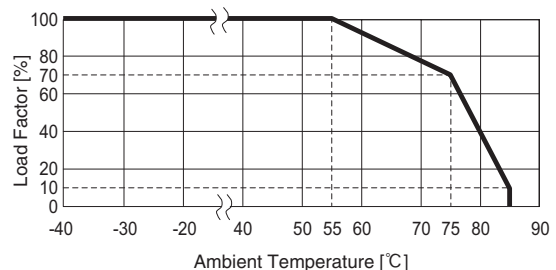

* Keep free ventilation holes for cooling.

External view

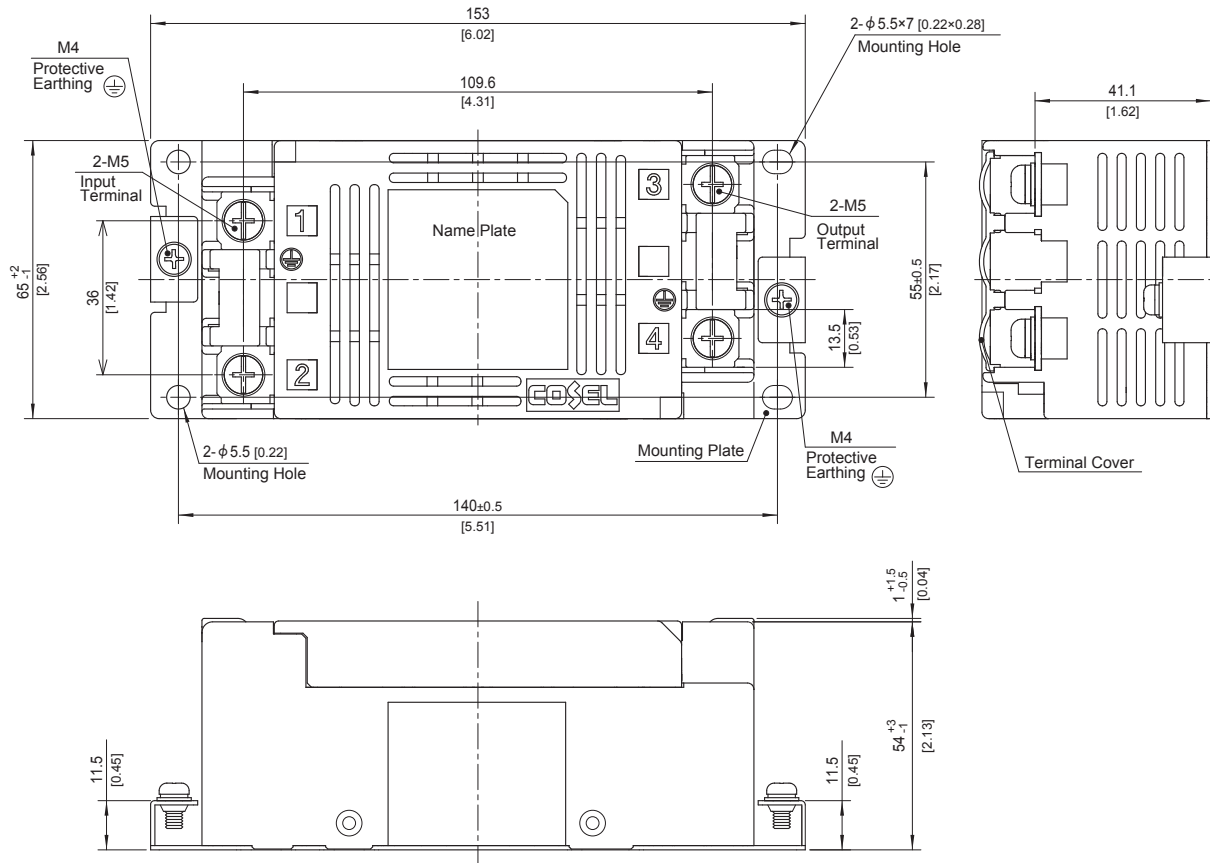

- ※ Dimensions in mm, []=inches
- ※ Tolerance: ±1 [±0.04]
- ※ Weight: 750g max
- ※ Mounting Plate: Hot-dip Galvanized Steel board t=1.0 [0.04]
- ※ Case Material: PBT
- ※ Terminal block screw tightening torque M5: 3.0N·m max
- ※ Protective Earthing (PE) screw tightening torque M4 : 1.6N·m max
- ※ Can not be mounted upside-down. (mounted the top surface)
- ※ Keep free ventilation holes for cooling.
- ※ Can be mounted using the 2 corner mounting holes.