

May.1.2017 Copyright 2017 HIROSE ELECTRIC CO., LTD. All Rights Reserved.

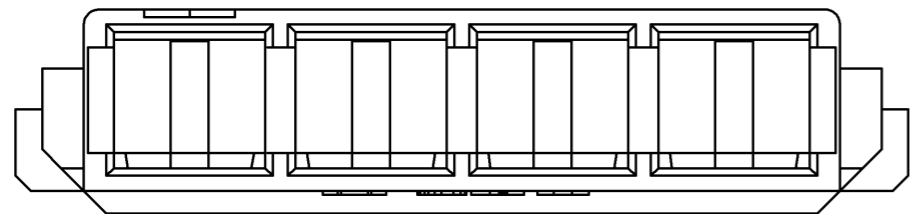
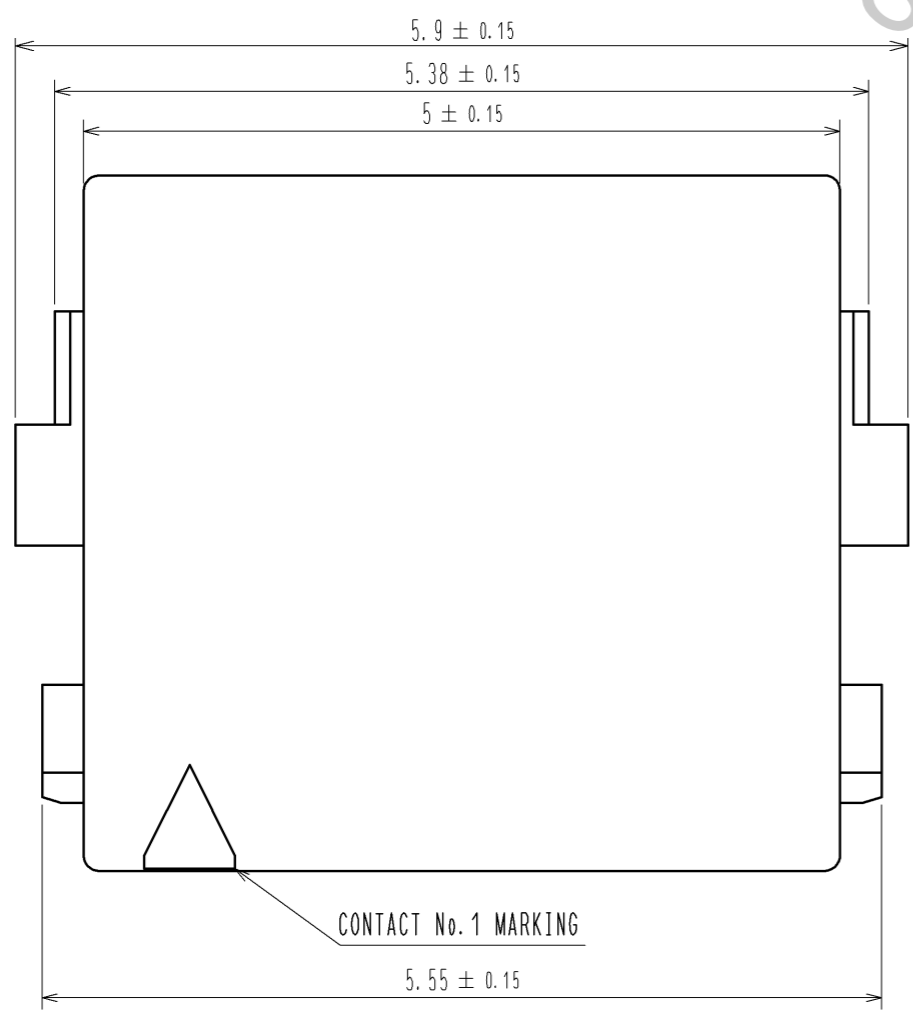
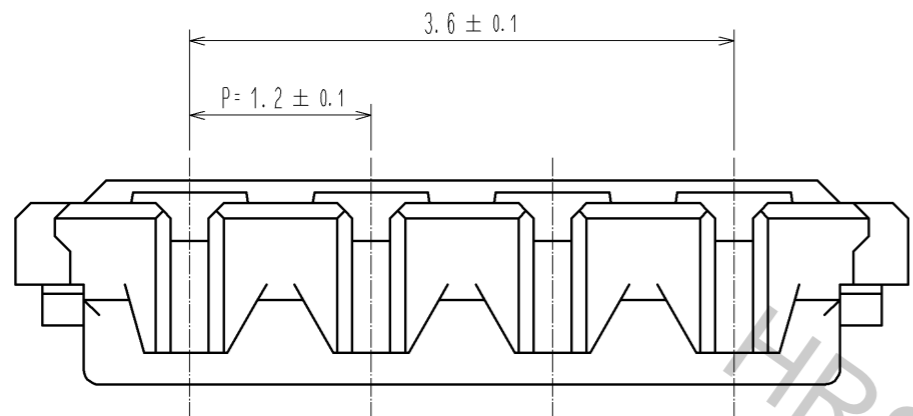

1) FIGURE OF INSERTION

HORIZONTALLY ○

DF57H-4S-1.2C

DIAGONAL ×

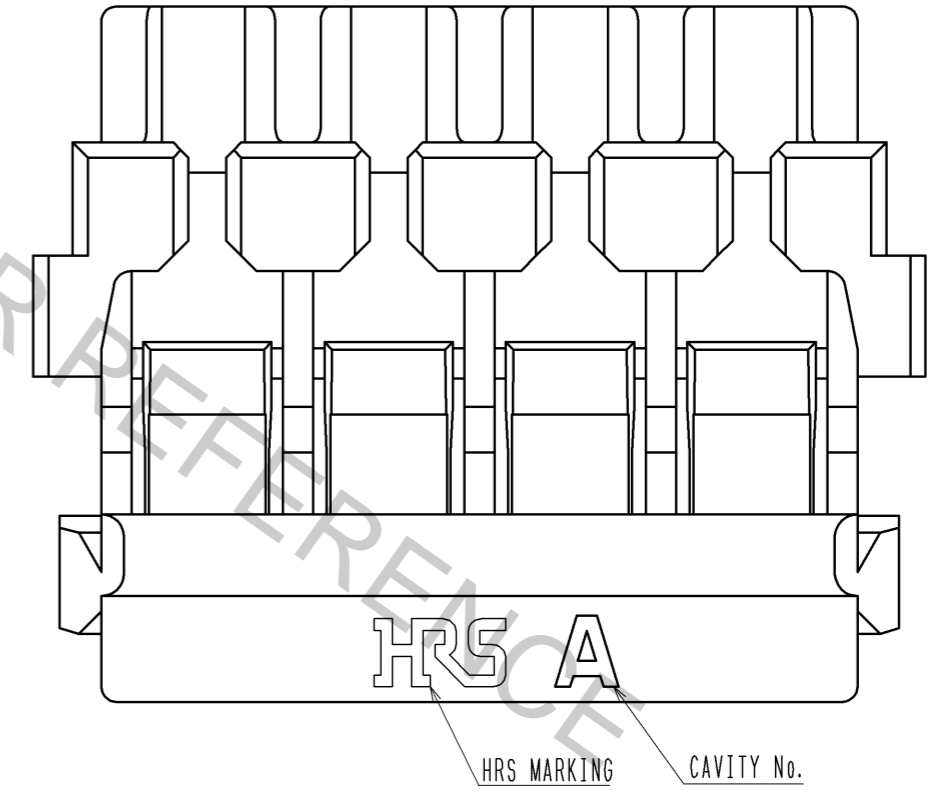
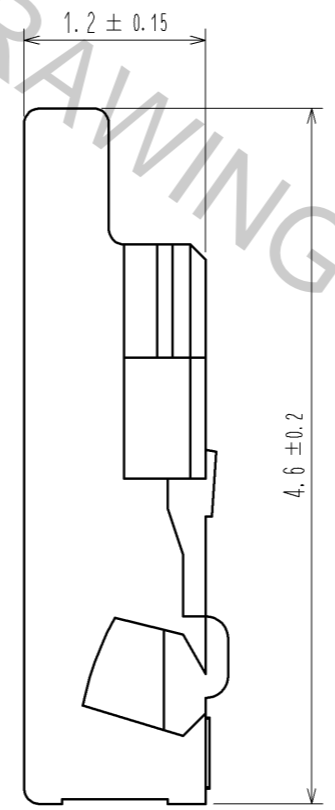
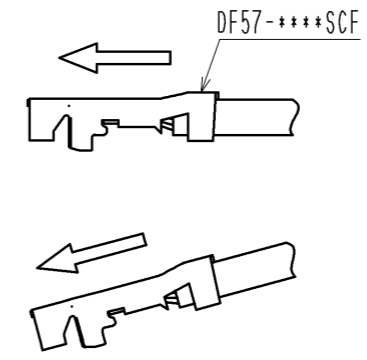
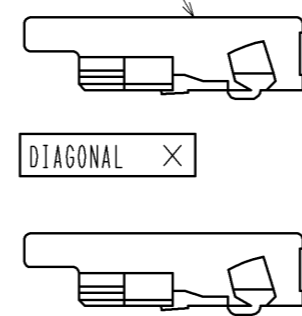

NOTE 1) AVOID ANGLED INSERTION OF CRIMP CONTACT(DF57-\*\*\*SCF) TO MAINTAIN PERFORMANCE RELIABILITY.

部番	材質	処 理 , 備 考	1	PBT	UL94V-0, NATURAL(WHITE)
UNITS mm		SCALE 20:1	△の数	訂 正 記 事	設 計
<b>HRS</b> HIROSE ELECTRIC CO., LTD.	承認 : KI. AKIYAMA 12.03.19	検 査 : HK. UMEHARA 12.03.19	設 計 : TS. KUMAZAWA 12.03.19	製 図 : TS. KUMAZAWA 12.03.19	図番 : EDC3-343901-00
					製品名 : DF57H-4S-1.2C
					製品コード : CL666-0101-9-00

# DF57 Series Mating / Unmating Operation Instruction

## Mating

① By positioning the convexity of the socket sides to the header concavity, align the centers of the socket and the header in pitch direction.

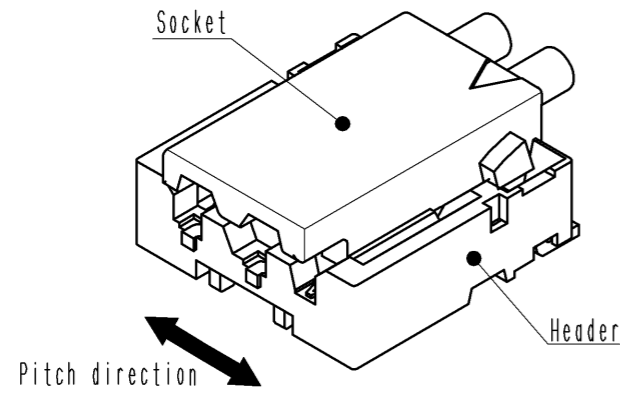

② Slightly press the socket down at cable side to tilted angle.

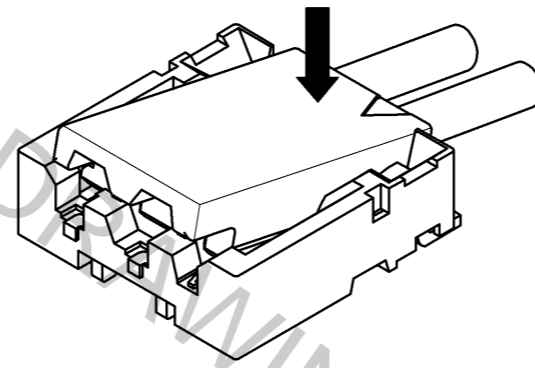

③ Press down at the lever side with stabilizing the cable side to insert. Mating completes.

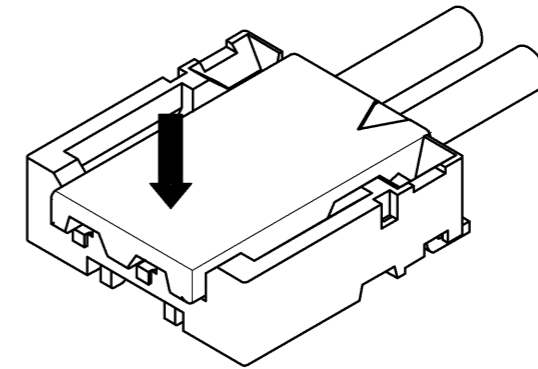

## Unmating

① Hook the lever with finger nail.

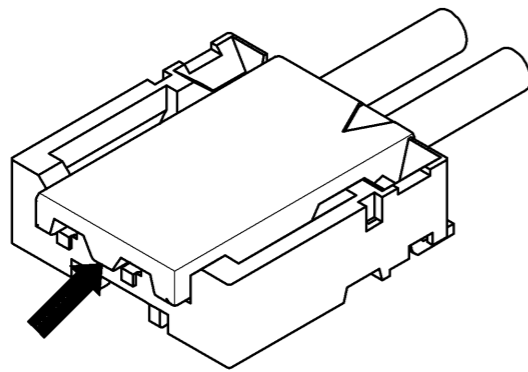

② Lift up to the upper direction and friction lock is released.

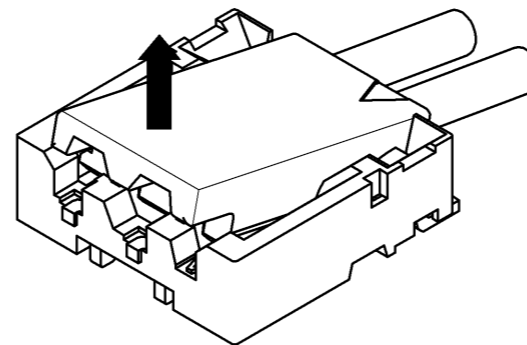

③ Lift up to the upper direction and positive lock is released. Removal completes.

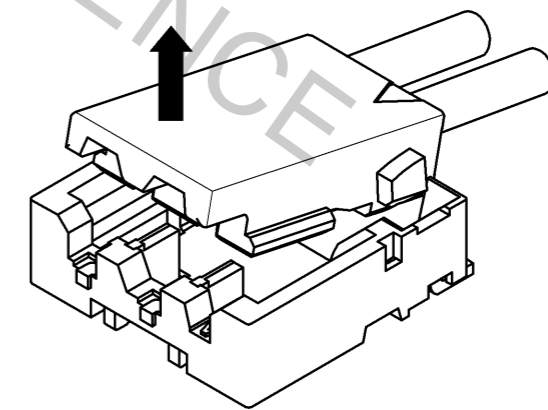

<b>HRS</b>	DRAWING NO.	EDC3-343901-00	△ 2/2
	PART NO.	DF57H-4S-1.2C	
	CODE NO.	CL666-0101-9-00	