



MAX5969B Evaluation Kit

General Description

The MAX5969B evaluation kit (EV kit) is a fully assembled and tested surface-mount circuit board featuring an Ethernet port, network powered-device (PD) interface-controller circuit for IEEE® 802.3af/at-compliant power-over-Ethernet (PoE) systems. The EV kit features the MAX5969B IEEE 802.3af/at-compliant network PD interface controller IC in a 10-pin TDFN package. The MAX5969B is used in PoE applications requiring DC power from an Ethernet network port for PDs such as IP phones, wireless access nodes, and security cameras.

The EV kit receives power from IEEE 802.3af/at-compliant power-sourcing equipment (PSE). Refer to the MAX5965 and MAX5971 IC data sheets for PSE controllers. The PSE provides the required -30V to -57V DC power over an unshielded twisted-pair Ethernet network cable to the EV kit's RJ45 magnetic jack. The EV kit features a 1 x 1GbE RJ45 magnetic jack and two diode bridges for separating the DC power provided by an endspan or midspan Ethernet system.

The EV kit can also be powered by a wall adapter power source. The EV kit provides PCB pads to accept the output of a wall adapter power source. When a wall adapter power source is detected, it always takes precedence over the PSE source, allowing the wall adapter to power the EV kit.

The EV kit demonstrates the full functionality of the IC, such as PD detection signature, PD classification signature, in-rush current control, and input under-voltage lockout (UVLO). The EV kit also provides a modular RJ45 jack to interface with the Ethernet data signals only.

The EV kit also features a galvanically isolated 22.7W, 600kHz switching frequency flyback DC-DC converter, which uses the MAX15000A current-mode PWM controller. The IC's output provides power for the converter circuit. The DC-DC converter is configured for an output voltage of +12V and provides up to 1.9A. High efficiency up to 89% is achieved using a single transistor flyback DC-DC converter topology. The surface-mount transformer provides up to +1500V galvanic isolation for the output. UVLO, soft-start, and thermal shutdown provide a robust 22.7W isolated power supply. The DC-DC converter operates at 600kHz, allowing the use of small magnetics and output capacitors. The EV kit can also evaluate the MAX5969A after IC replacement (U1).

Features

- ◆ IEEE 802.3af/at-Compliant PD Interface Circuit
- ◆ -30V to -57V Input Range
- ◆ Demonstrates an Isolated +12V/22.7W Flyback DC-DC Converter
- ◆ PD Detection and Configurable Classification Signatures
- ◆ 2-Event Classification or Wall Adapter Detect Output
- ◆ Power-Good Indicator Output
- ◆ In-Rush Current Limit of 180mA (max)
- ◆ Evaluates Endspan and Midspan Ethernet Systems
- ◆ Evaluates the MAX5969B/MAX5969A in a 10-Pin TDFN Package
- ◆ Simplified Wall Adapter Interface
- ◆ Fully Assembled and Tested

Ordering Information

PART	TYPE
MAX5969BEVKIT+	EV Kit

+Denotes lead(Pb)-free and RoHS compliant.

Component List

DESIGNATION	QTY	DESCRIPTION
C1	1	0.1µF ±10%, 100V X7R ceramic capacitor (0805) Murata GRM21BR72A104K
C2	1	0.1µF ±10%, 100V X7R ceramic capacitor (0603) Murata GRM188R72A104K
C3	1	1000pF ±10%, 50V X7R ceramic capacitor (0402) Murata GRM155R71H102K
C4	1	1000pF ±10%, 250V AC X7R ceramic capacitor (1206) AVX Corp. 1206GC102KAT1A

IEEE is a registered service mark of the Institute of Electrical and Electronics Engineers, Inc.

Evaluates: MAX5969A/MAX5969B



MAX5969B Evaluation Kit

Evaluates: MAX5969A/MAX5969B

Component List (continued)

DESIGNATION	QTY	DESCRIPTION
C5, C8	2	1 μ F \pm 10%, 100V X7R ceramic capacitors (1210) Murata GRM32CR72A105K
C6	1	4.7 μ F \pm 20%, 35V aluminum electrolytic capacitor (4mm x 5.8mm) Panasonic EEEFK1V4R7R
C7	1	68 μ F \pm 20%, 63V aluminum electrolytic capacitor (8mm x 10.2mm) SANYO 63CE68FS
C9, C12, C20	3	0.1 μ F \pm 10%, 50V X7R ceramic capacitors (0603) Murata GRM188R71H104K
C10	1	330pF \pm 10%, 50V X7R ceramic capacitor (0402) Murata GRM155R71H331K
C11	1	0.1 μ F \pm 10%, 16V X7R ceramic capacitor (0402) Murata GRM155R71C104K
C13	1	5600pF \pm 10%, 25V X7R ceramic capacitor (0402) Murata GRM155R71E562K
C14	1	100pF \pm 5%, 50V C0G ceramic capacitor (0402) Murata GRM1555C1H101J
C15	1	8200pF \pm 10%, 25V X7R ceramic capacitor (0402) Murata GRM155R71E822K
C16	1	2200pF \pm 10%, 250VAC X7R UL ceramic capacitor (1812) Murata GA343QR7GD222K
C17, C18, C19	3	47 μ F \pm 10%, 16V X5R ceramic capacitors (1210) Murata GRM32ER61C476K
C21	0	Not installed, capacitor (0805)
C24	0	Not installed, capacitor (0402)

DESIGNATION	QTY	DESCRIPTION
D1	1	56.7V, 600W transient voltage suppressor (SMB) Fairchild SMBJ51A (Top Mark: MZ)
D2	1	100V, 2A diode rectifier (SMB) Diodes Inc. ES2B-13-F
D3, D4	2	200V, 1A bridge rectifiers (MiniDIP) Diodes Inc. HD02
D5	1	27V, 500mW zener diode (SOD123) Diodes Inc. BZT52C27 (Top Mark: WP)
D6	1	75V, 150mA switching diode (SOD323) Diodes Inc. 1N4148WS (Top Mark: T4 or T6)
D7	1	60V, 7A Schottky diode (PowerDI [®] 5) Diodes Inc. PDS760
J3	1	Modular side-entry, 8-position jack assembly Tyco Electronics 5520252-4
L1	1	3.3 μ H, 2.26A inductor Cooper Bussmann SD53-3R3-R (Top Mark: C)
N1	1	150V, 4.1A n-channel MOSFET (8 SO) Fairchild FDS2582
Q1	0	Not installed, transistor (SOT23)
RJ45	1	1GbE IEEE 802.3af/at-compliant RJ45 MagJack [®] Bel Fuse 0826-1X1T-GH-F
R1, R8	2	24.9k Ω \pm 1% resistors (0603)
R2	1	30.9 Ω \pm 1% resistor (0805)
R3, R7	2	59k Ω \pm 1% resistors (0402)
R4, R5, R30, R32, R33	0	Not installed, resistors (0402)

PowerDI is a registered trademark of Diodes Incorporated.
MagJack is a registered trademark of Bel Fuse Inc.

MAX5969B Evaluation Kit

Component List (continued)

DESIGNATION	QTY	DESCRIPTION
R6	1	1.37M Ω \pm 1% resistor (0402)
R9, R10	2	10 Ω \pm 5% resistors (0805)
R11, R19	2	1k Ω \pm 1% resistors (0402)
R12, R13	2	0.39 Ω \pm 1%, 0.25W sense resistors (0805) Panasonic ERJ-6BQFR39V
R14	1	8.25k Ω \pm 1% resistor (0402)
R15	1	845 Ω \pm 1% resistor (0402)
R16	1	4.99k Ω \pm 1% resistor (0402)
R17, R18, R22	3	10k Ω \pm 1% resistors (0402)
R20	1	0 Ω \pm 5% resistor (0402)
R21	1	3.32k Ω \pm 1% resistor (0402)
R23	1	9.53k Ω \pm 1% resistor (0402)
R24	1	23.2k Ω \pm 1% resistor (0402)
R25	1	2.49k Ω \pm 1% resistor (0402)
R26	0	Not installed, resistor (0805)
R27, R28, R29, R31	4	75 Ω \pm 5% resistors (0402)

DESIGNATION	QTY	DESCRIPTION
R34	1	100k Ω \pm 5% resistor (0402)
T1	1	12V, 30W flyback transformer Pulse PA2669NL EP13-10
U1	1	IEEE 802.3af-compliant PD (10 TDFN-EP*) Maxim MAX5969BETB+
U2	1	Current-mode PWM controller (10 μ MAX $^{\circledR}$) Maxim MAX15000AEUB+
U3	1	70V, 200% to 400% phototransistor CTR (4 surface-mount DIP) Fairchild FOD817CSD
U4	1	2.5V precision shunt regulator (5 SOT23)
—	1	PCB: MAX5969B EVALUATION KIT+

*EP = Exposed pad.

Component Suppliers

SUPPLIER	PHONE	WEBSITE
AVX Corporation	843-946-0238	www.avxcorp.com
Bel Fuse Inc.	201-432-0463	www.belfuse.com
Cooper Bussmann	916-941-1117	www.cooperet.com
Diodes Incorporated	805-446-4800	www.diodes.com
Fairchild Semiconductor	888-522-5372	www.fairchildsemi.com
Murata Electronics North America, Inc.	770-436-1300	www.murata-northamerica.com
Panasonic Corp.	800-344-2112	www.panasonic.com
Pulse Engineering	858-674-8100	www.pulseeng.com
SANYO Electric Co., Ltd.	619-661-6835	www.sanyo.com
Tyco Electronics	800-522-6752	www.tycoelectronics.com

Note: Indicate that you are using the MAX5969B when contacting these component suppliers.

μ MAX is a registered trademark of Maxim Integrated Products, Inc.

MAX5969B Evaluation Kit

Quick Start

Required Equipment

- IEEE 802.3af/at-compliant PSE and Category 5e Ethernet network cable
- -48V, 1A-capable DC power supply
- MAX5969B EV kit
- Voltmeter

Hardware Connections

The MAX5969B EV kit is fully assembled and tested. Follow the steps below to verify board operation.

Caution: Do not turn on the power supply until all connections are completed.

- 1) Use one of the following methods to power the EV kit:
 - **If network connectivity is required:** Connect a Category 5e Ethernet network cable from the EV kit input port RJ45 connector to the corresponding PSE Ethernet LAN connection, which provides power to the EV kit. A modular RJ45 jack (J3) provides an interface with the Ethernet data signals only.
 - **If network connectivity is not required:** Connect a -48V DC power supply between the VDD and VSS pads on the EV kit. Connect the power-supply positive terminal to the VDD pad and the negative terminal to the VSS pad.
- 2) Activate the PSE power supply or turn on the external DC power supply.
- 3) Using a voltmeter, verify that the EV kit provides +12V across the +12V and GND pads. GND is galvanically isolated from the EV kit's input VDD and WAD pads.

Detailed Description of Hardware

The MAX5969B EV kit features an Ethernet port, network PD interface-controller circuit for -57V supply rail systems. The EV kit contains a MAX5969B IEEE 802.3af/at-compliant PD controller IC in a 10-pin TDFN package with an exposed pad. The IC is used in PoE applications for powering PDs from an unshielded twisted-pair (UTP) Ethernet Category 5e network cable and PSE port using endspan or midspan Ethernet systems.

The EV kit receives power from an IEEE 802.3af/at-compliant PSE and a UTP cable connected to the EV kit's RJ45 magnetic jack. The EV kit uses a 1 x 1GbE RJ45 magnetic jack and two diode-bridge power rectifiers (D3, D4) to separate the -57V DC power sent by

the PSE. The EV kit accepts power from an endspan or midspan PSE network configuration. The EV kit also provides an RJ45 jack (J3) for interface to the Ethernet data signals only.

The EV kit can also accept power from a wall adapter power source. When a wall adapter power source is detected between the WAD and RTN PCB pads, the IC's internal isolation switch disconnects VSS from RTN, which allows the wall adapter to supply power to the EV kit.

The EV kit demonstrates the full functionality of the MAX5969B, such as PD detection signature, PD classification signature, in-rush current control, and UVLO. The EV kit also provides modular jack J3 to interface with the Ethernet data signals from the RJ45 magnetic jack. Resistor R1 sets the PD detection signature; the PD classification signature is determined by resistor R2.

The EV kit's galvanically isolated 22.7W flyback DC-DC converter uses a MAX15000A current-mode PWM controller. The MAX5969B's VDD and RTN pins provide power for the DC-DC converter input circuit. The DC-DC converter is configured for an output voltage of +12V and provides up to 1.9A at the output, while achieving up to 89% efficiency. Minimal component count is achieved using a single transistor (N1) flyback DC-DC converter topology. The surface-mount transformer (T1) provides up to 1500V galvanic isolation for the output. Current-sense resistors R12 and R13 limit the peak current through transistor N1 and the primary of transformer T1. Isolated feedback voltage is achieved using optical coupler U3 and shunt regulator U4. Voltage feedback resistors R23 and R25 set the output voltage. Resistor R26 and capacitor C21 form a snubber network that suppresses transient overvoltage ringing at diode D7 caused by transformer T1's leakage inductance and the junction capacitance of diode D7.

Internal UVLO, soft-start, and thermal shutdown within the MAX15000A provide for a robust 22.7W isolated power-supply design. The MAX15000A PWM controller operates at 600kHz and the switching duty cycle is limited to 50% (max). Refer to the MAX15000 IC data sheet for more information on this controller.

Warning: The MAX5969B EV kit is designed to operate with high voltages. Dangerous voltages are present on this EV kit and on equipment connected to it. Users who power up this EV kit or power the sources connected to it must be careful to follow safety procedures appropriately when working with high-voltage electrical equipment.

MAX5969B Evaluation Kit

Table 1. PD Classification Signature Selection

CLASS	MAXIMUM POWER USED BY PD (W)	RESISTOR R2 (Ω)
0	0.44 to 12.95	619
1	0.44 to 3.84	118
2	3.84 to 6.49	66.5
3	6.49 to 12.95	43.2
4	12.95 to 25.5	30.9
5	> 25.5	21.5

Under severe fault or failure conditions, this EV kit can dissipate large amounts of power, which could result in the mechanical ejection of a component or of component debris at high velocity. Operate this EV kit with care to avoid possible personal injury.

PD Classification Signature

By default, the EV kit is set for a Class 4 (12.95W to 25.5W) PD classification by resistor R2. To change the PD classification, replace surface-mount resistor R2. Table 1 lists the PD classification options.

Wall Adapter Power Source (WAD, RTN)

The EV kit can also accept power from a wall adapter power source. Use the WAD PCB pad for connecting the more positive terminal and the RTN PCB pad for connecting the more negative terminal to the wall adapter

power source. The wall adapter power-source operating-voltage range must be within +30V to +57V for the EV kit.

When the wall adapter power source is above +10V, it takes precedence over the PSE source. Once the wall adapter power source is detected, the IC's internal isolation switch disconnects VSS from RTN. The wall adapter power is supplied to VDD (through diode D2) and RTN. Once it takes over, the classification process is disabled.

When the wall adapter power source is below +7V, the PSE provides power through the IC's RTN. Diode D2 prevents the PSE from back-driving the wall adapter power source when it is below +7V.

Ethernet Data Signal Interfacing

The EV kit features a modular RJ45 jack (J3) to interface with the Ethernet data signals. J3 is provided for interfacing the EV kit with the Ethernet data signals only. Refer to the RJ45 magnetic jack data sheet on the Bel Fuse website prior to interfacing the EV kit's J3 modular RJ45 jack with the Ethernet data signals.

Evaluating the MAX5969A

The EV kit can also evaluate the MAX5969A. Remove the MAX5969B IC (U1) and replace it with the MAX5969A. The MAX5969A is pin compatible with the MAX5969B. The MAX5969A has a lower UVLO of -35.4V compared to the MAX5969B's UVLO of -38.6V. Refer to the MAX5969A/MAX5969B IC data sheet for additional information.

Evaluates: MAX5969A/MAX5969B

MAX5969B Evaluation Kit

Evaluates: MAX5969A/MAX5969B

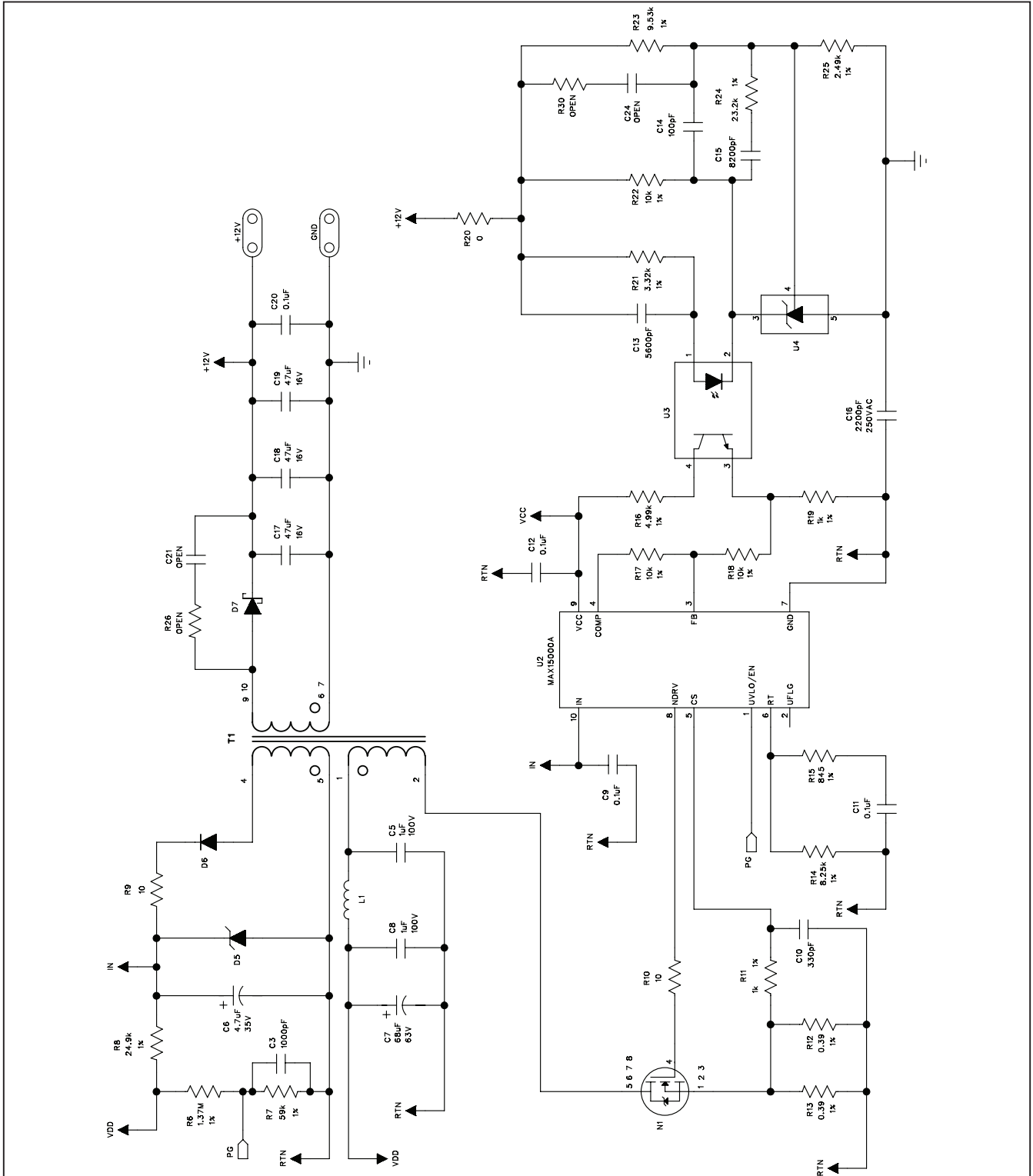

Figure 1b. MAX5969B EV Kit Schematic—12V, 22W Isolated Power-Supply Circuit (Sheet 2 of 2)

MAX5969B Evaluation Kit

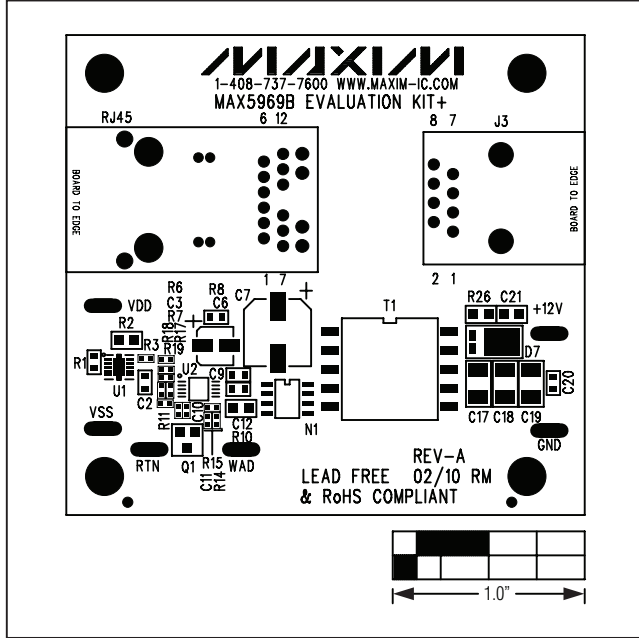

Figure 2. MAX5969B EV Kit Component Placement Guide—Component Side

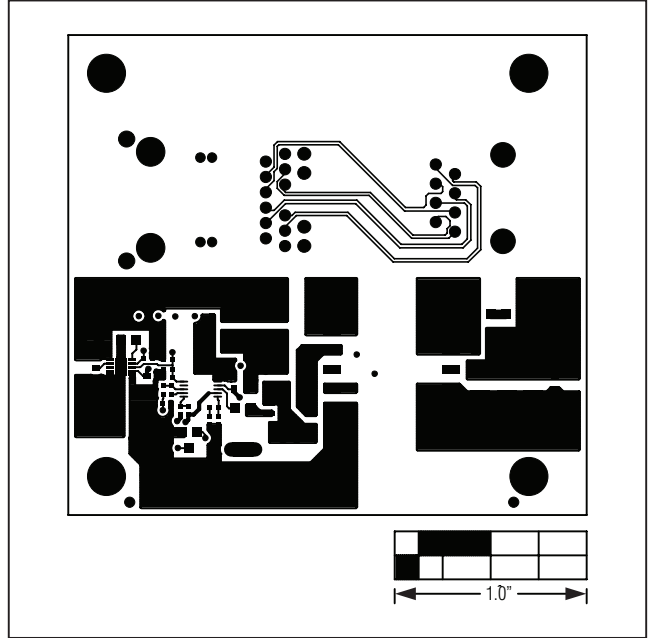

Figure 3. MAX5969B EV Kit PCB Layout—Component Side

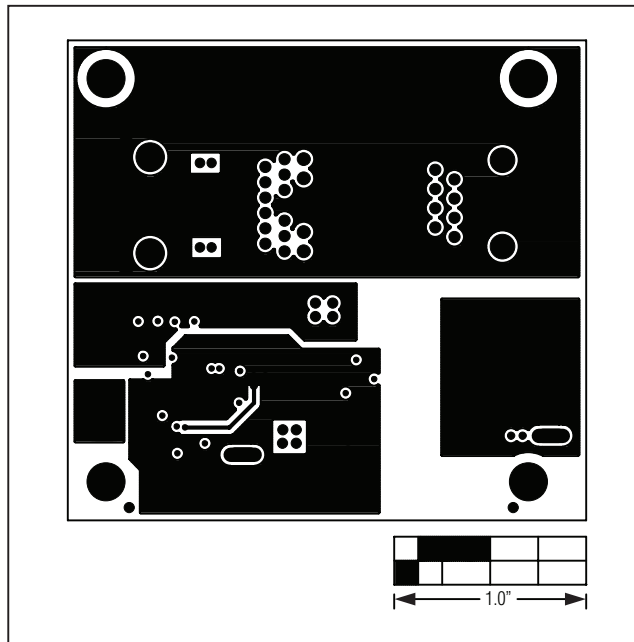

Figure 4. MAX5969B EV Kit PCB Layout—GND Layer 2

MAX5969B Evaluation Kit

Evaluates: MAX5969A/MAX5969B

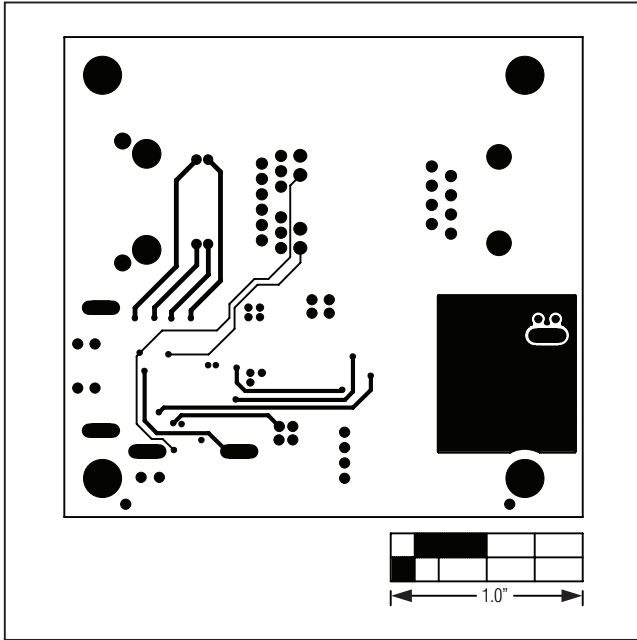

Figure 5. MAX5969B EV Kit PCB Layout—VCC Layer 3

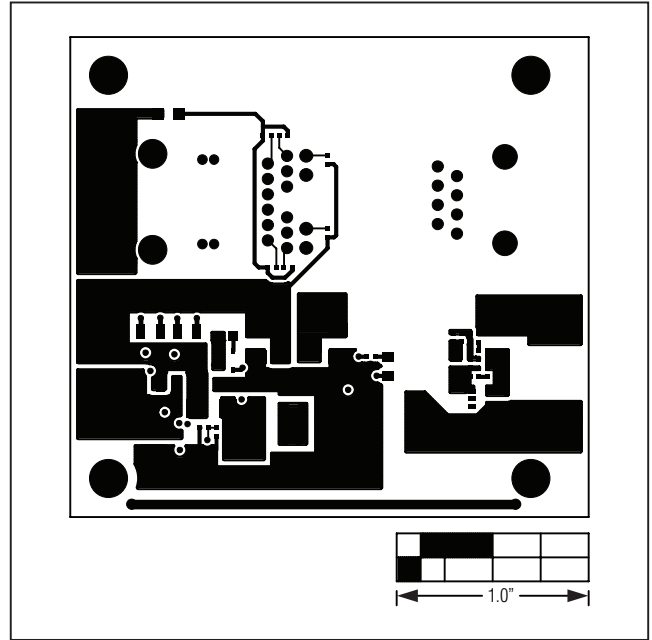

Figure 6. MAX5969B EV Kit PCB Layout—Solder Side

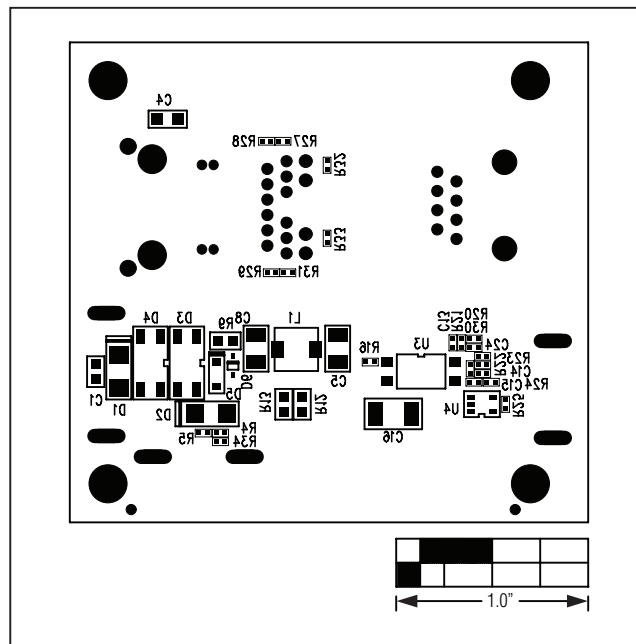

Figure 7. MAX5969B EV Kit Component Placement Guide—Solder Side

Maxim cannot assume responsibility for use of any circuitry other than circuitry entirely embodied in a Maxim product. No circuit patent licenses are implied. Maxim reserves the right to change the circuitry and specifications without notice at any time.

Maxim Integrated Products, 120 San Gabriel Drive, Sunnyvale, CA 94086 408-737-7600 _____ 9

Mouser Electronics

Authorized Distributor

Click to View Pricing, Inventory, Delivery & Lifecycle Information:

[Analog Devices Inc.:](#)

[MAX5969BEVKIT+](#)