

NEMA 4 1/8 DIN SERIES ENCLOSURES

ENC5B & ENC5C - PLASTIC ENCLOSURES

- RUGGED POLYCARBONATE CONSTRUCTION
- COMPLETELY SEALED FOR NEMA 4X/IP65 WASH-DOWN
- EASY MOUNTING OPTIONS

DESCRIPTION

These enclosures are designed for applications requiring a water resistant instrument enclosure. The ENC5B and ENC5C enclosures are fabricated of polycarbonate and are designed to withstand NEMA 4X/IP65 wash-down applications. The enclosures must be drilled to accept conduit fittings or other types of wiring connectors. The enclosures can be used free-standing, or securely fastened to a mounting surface. The enclosures are precut for either one or two meters. When properly installed, the meter and the enclosure can withstand NEMA 4X wash-down applications.

Electrical connections to the enclosed instrument are easily made by drilling the desired location on the back or side of the enclosure. Select the proper drill size to accommodate the conduit fitting or other wire connector. To maintain the enclosure NEMA 4X rating, sealed connectors must be used. Also enclosed are wall fastening lugs, which can be used to easily mount the enclosure to a wall.

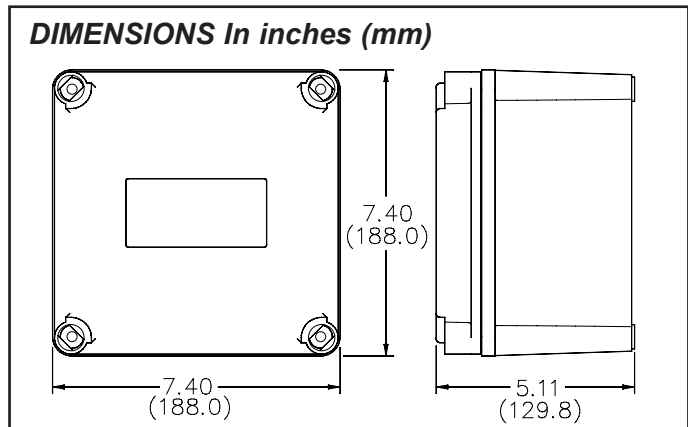

ORDERING INFORMATION

MODEL NO	DESCRIPTION	PART NUMBER
ENC5B	NEMA 4X/IP65 Enclosure for One 1/8 DIN Meter	ENC5B000
ENC5C	NEMA 4X/IP65 Enclosure for Two 1/8 DIN Meters	ENC5C000

ENC5B AND ENC5C INSTALLATION

It is recommended to wire the unit before mounting it in the enclosure to ensure good electrical connections. The following steps outline the most common sequence for installing a unit.

1. Determine the location of the conduit fitting and drill the necessary hole. Install the fitting and bring the wiring into the enclosure.
2. Slide the panel gasket over the rear of the unit to the back of the bezel.
3. Install the unit through the opening in the front of the lid until the bezel flange contacts the panel.
4. Slide the mounting plate over the rear of the unit until it is against the inside front of the enclosure.
5. Slide the mounting clip over the rear of the unit until the mounting clip is against the inside of the mounting plate. The mounting clip has latching features which engage into mating features on the unit's housing.
Note: It is necessary to hold the unit in place when sliding the mounting clip into position.
6. While holding the unit in place, push the panel latch over the rear of the unit so that the tabs of the panel latch engage in the slots on the case. The panel latch should be engaged in the farthest forward slot possible. To achieve a proper seal, tighten the latch screws evenly until the unit is snug in the panel (Torque to approximately 7 in-lbs [79 N-cm]). Do not over-tighten the screws.
7. If the gasket is not adequately compressed, and the mounting screws can no longer be turned, loosen the mounting screws and check that the mounting clip is latched as close as possible to the inside of enclosure. Repeat the procedure for tightening the screws.
8. Connect the necessary wires to the unit for the application desired.
9. Assemble the enclosure with the screws provided. Alternately tighten each screw to ensure uniform gasket pressure.

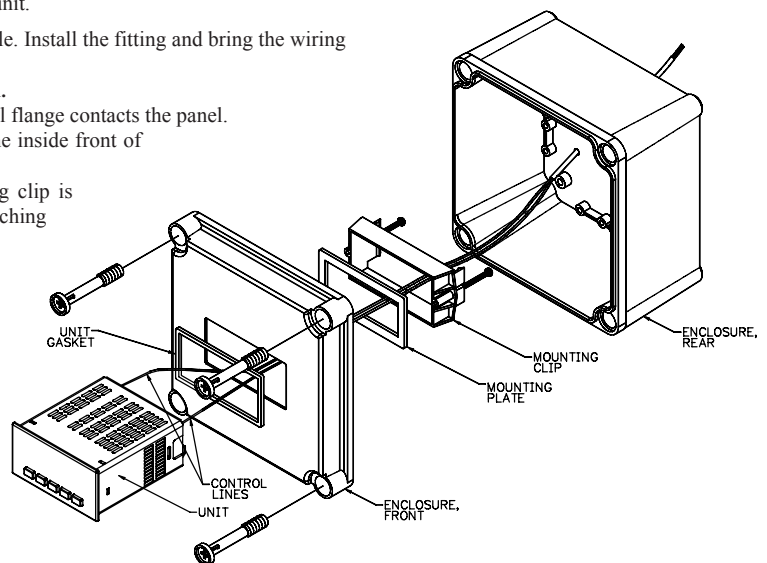

ENC5A - STEEL ENCLOSURE



- RUGGED STEEL CONSTRUCTION
- COMPLETELY SEALED FOR NEMA 4/IP65 WASH-DOWN
- VERSATILE MOUNTING OPTIONS FOR MACHINE OR DESKTOP

DESCRIPTION

The ENC5A enclosure is fabricated of formed steel with all seams welded to withstand NEMA 4/IP65 wash-down applications. The kit is coated with a durable flat black polyurethane finish.

Electrical connections to the enclosed instrument are easily made through a removable access panel at the rear of the enclosure. The panel must be drilled to accept conduit fittings or other types of wiring connectors.

The enclosure can be used free-standing or securely fastened to a mounting surface with brackets which are provided with each enclosure. The brackets also allow the enclosure to be raised and/or tilted from the mounting surface in order to achieve the most favorable operating position. Self-stick rubber pads are provided which can be applied to the bottom of the enclosure. These rubber pads will protect the mounting surface and are particularly useful for free-standing installations.

DIMENSIONS In inches (mm)

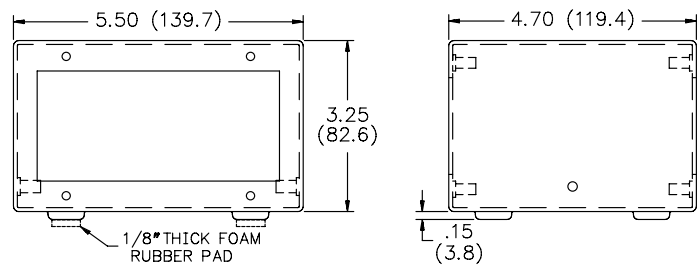

ORDERING INFORMATION

MODEL NO.	DESCRIPTION	PART NUMBER
ENC5A	NEMA 4/IP65 Enclosure for 1/8 DIN Meter	ENC5A000

ENC5A INSTALLATION

1. Mark the location on the rear panel for your wire connector or conduit fitting, and drill the necessary hole. Connect your wire connector or fitting to the rear panel.
2. Remove the center sections of the front and rear panel gaskets. These centers contain the optional foam rubber feet for the enclosure.
3. Apply the adhesive side of the panel gasket to the front and rear openings of the enclosure. **DO NOT APPLY THE ADHESIVE SIDE OF THE GASKET TO THE FRONT OR REAR PANELS.**
4. Install the unit to the front panel according to the standard panel installation instructions found in the product literature.
5. Route the wires to be connected to the unit from the conduit fitting through the rear of the enclosure and out the front.
6. Connect the necessary wires to the unit for the application desired.
7. Attach the front and rear panels to the enclosure with the screws and washers provided. Alternately tighten each screw to ensure uniform gasket compression. Visually inspect the sponge rubber gasket. The gasket should be compressed to about 75 to 80% of its original thickness.
8. For a free-standing enclosure, apply the self-stick foam rubber pads to the features on the bottom of the enclosure to protect the mounting surface.
9. To securely mount the enclosure, attach the adjustable mounting brackets to the enclosure using the washers and bolts provided. Secure the mounting brackets to the desired mounting location. The mounting screws to attach the brackets to your surface are not provided due to the variety of installation options available.

