

**STRAIGHT PLUG CRIMP TYPE
CABLE 2.6/50 S**

R141.075.000
SERIES BNC

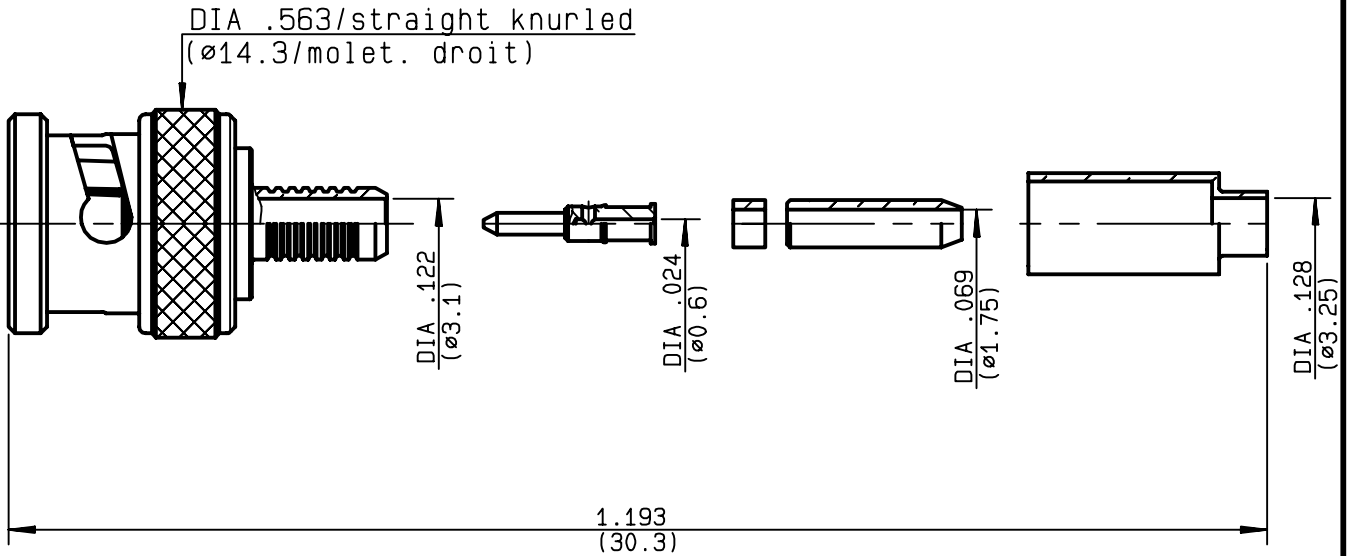

NOMINAL IMPEDANCE	50 Ω	CABLES : KX 22A
FREQUENCY RANGE	0-4 GHz	RG 188
TEMPERATURE RATING	-65/+165 °C	RG 316
V.S.W.R	1.2 + 0 x F(GHz)Maxi	
RF INSERTION LOSS	0.115 √F(GHz) dB Maxi	
VOLTAGE RATING	335 Veff Maxi	
DIELECTRIC WITHSTANDING VOLTAGE	1000 Veff Mini	
INSULATION RESISTANCE	5000 MΩMini	OTHERS CHARACTERISTICS
HERMETIC SEAL	NA Atm.cm ³ /s	CABLE RETENTION
LEAKAGE (pressurized only)	NA	40 N Mini
MECHANICAL DURABILITY	500 Cycles	CENTER CONTACT RETENTION
WEIGHT	10 gr	Axial force - mating end
SPECIFICATION		27 N Mini
		Axial force - opposite end
		27 N Mini
		Torque
		NA cm.N Mini
		RECOMMENDED TORQUES
		Mating
		NA cm.N
		Panel nut
		NA cm.N
		Clamp nut
		NA cm.N

CONNECTOR PARTS	MATERIALS	FINISH	(all values are given in micrometers)
BODY	BRASS	NICKEL 2	
OUTER CONTACT			
CENTER CONTACT	BRASS	GOLD 0.5 OVER NICKEL 2	
INSULATOR	PTFE	-	
GASKET	SILICONE RUBBER	-	
OTHERS PIECES	BRASS	NICKEL 2	

ISSUE 9945L00	CREATION DATE 04/04/1995	FILE PART-NUMBER
-------------------------	------------------------------------	------------------



RADIALL®

ILLMER

The information given here is subject to change without notice.
Design changes may be in order to improve the product .

Connect to the future



R141.075.000

ISSUE 9945L00 SERIES BNC

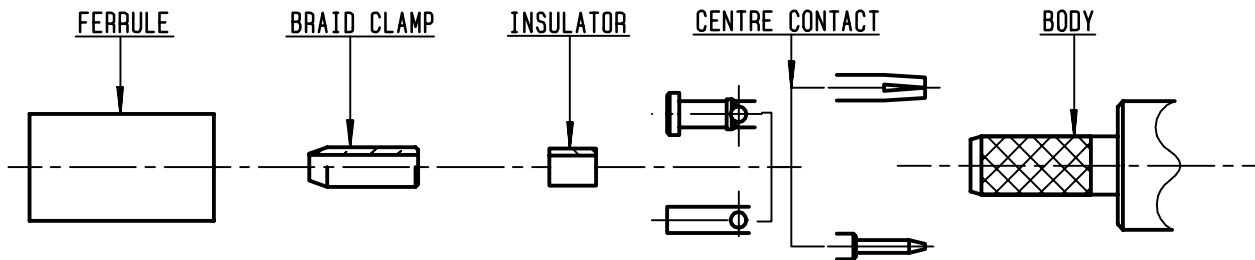

①

Slide onto the cable the ferrule
Strip the cable .

-
-

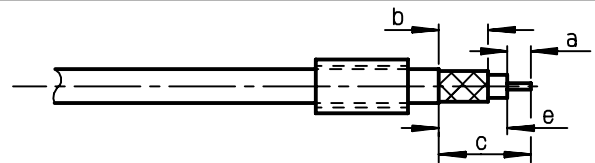

Stripping	a	b	c	d	e
inch	0.157	0.394	0.728	0	0.571
mm	4	10	18.5		14.5

②

Fan the braid .
Slide the braid clamp and insulator between the dielectric and the braid .
Slide on centre contact until it bottoms against cable dielectric .
Solder or crimp centre contact .
Crimping tool : R282 223 000 (Hex. : .068)
or crimping tool R282 293 000 (M22520/5-01)
+ dies R282 235 011 (M22520/5-11)

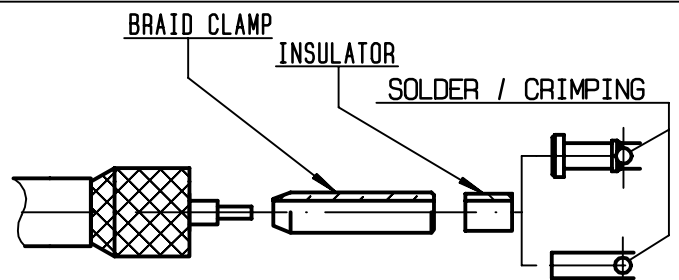

③

Slide cable into the body until bottoms against insulator .
Slide ferrule over the braid .
(In direction F)

-

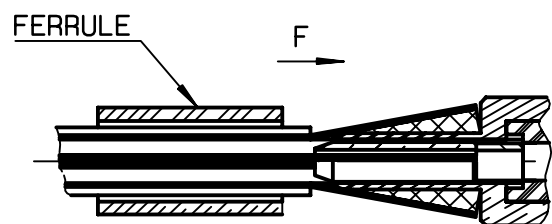

④

Crimp the ferrule with crimping tool R 282 223 000 (Hex. : .213) or crimping tool R282 293 000 (M22520/5-01)
+ dies R282 235 011 (M22520/5-11)
Cut the excess of braid .

-
-
-
-

