

1. External Dimensions (Unit:m/m)

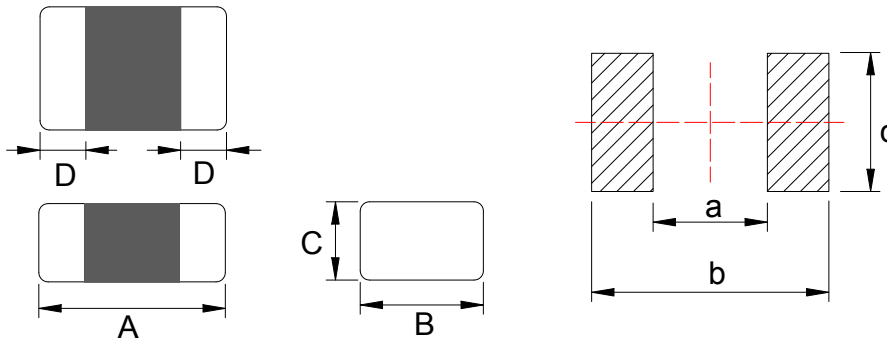

Type	A	B	C	D	a	b	c	Q'TY/Reel
APS25T12	2.5±0.2	2.0±0.2	1.25Max	0.6Ref	1.2Ref	2.8Ref	2.0Ref	3000

2. Part Number Code

APS 25 T 12 M 2R2
 A B C D E F

A: Series Name Metal Alloy Inductors
 B: Dimensions(mm) 25: 2.5x2.0
 C: Materials T Type
 D: Thickness(mm) 12: 1.25 Max
 E: Tolerance M: ±20%
 F: Inductance 2R2=2.2uH

3. Electrical Characteristics

Part Number	Inductance (μH)	Test Frequency (MHz)	DC Resistance (mΩ)Max.	Heat Rating Current Irms(A)	Saturation Current Isat(A)
APS25T12M2R2	2.2	1MHz	108.0	2.0	2.2

Notes:

- 1) All test data is referenced to 25°C ambient.
- 2) Operating temperature range -40°C to +125°C.
- 3) Irms :DC current(A) that will cause an approximate ΔT of 40°C.
- 4) Isat :DC current(A) that will cause I_o to drop approximately 40%.
- 5) The part temperature(ambient + temp rise)should not exceed 125°C under worst case operating conditions.Circuit design,component placement, PCB trace size and thickness,airflow and other cooling provisions all affect the part temperature,part temperature should be verified in the end application.

4. Test Data

ELECTRICAL CHARACTERISTIC				MECHANICAL DIMENSIONS			
SPEC	L(uH)	DCR(mΩ)	Isat(uH)	A(mm)	B(mm)	C(mm)	D(mm)
TOL	2.2	108.0	2.2A	2.5	2.0	1.25	0.6
NO	±20%	Max	(L0A-L2.2A) /L0A≈40%	±0.2	±0.2	Max	Ref
1	1.882	89.02	1.449	2.52	2.02	1.06	OK
2	1.949	90.06	1.520	2.53	2.02	1.05	OK
3	1.880	89.16	1.464	2.52	2.05	1.07	OK
4	1.907	89.56	1.487	2.51	2.05	1.06	OK
5	1.845	90.15	1.421	2.52	2.02	1.05	OK
6	1.858	88.95	1.449	2.53	2.03	1.06	OK
7	1.833	89.65	1.411	2.52	2.02	1.07	OK
8	1.857	88.79	1.448	2.52	2.04	1.05	OK
9	1.880	88.69	1.448	2.52	2.03	1.06	OK
10	1.865	89.67	1.455	2.51	2.09	1.04	OK

Test Equipments: IM3536,VR126,VR7210,Calipers

Curve:

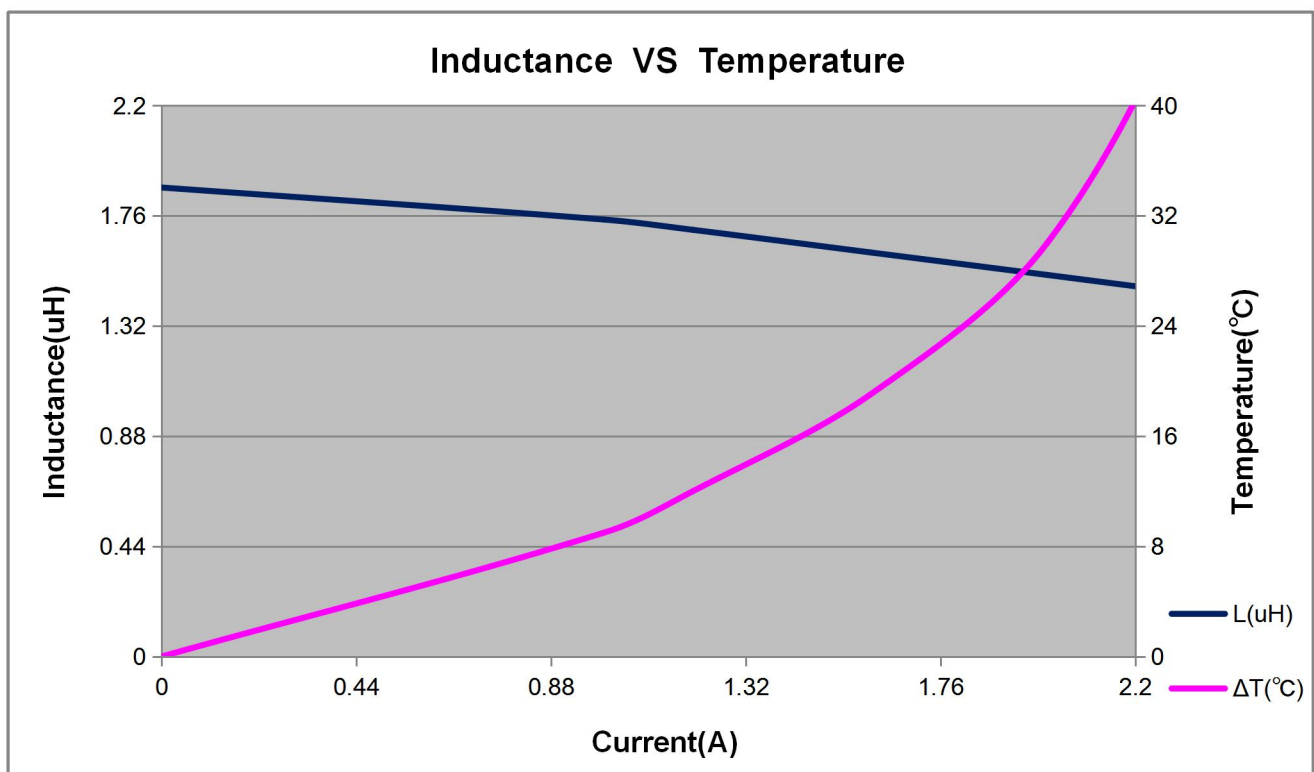

5. Test and Measurement Procedures

5.1 Test Conditions

5.1.1 Unless otherwise specified, the standard atmospheric conditions for measurement/test as:

- a. Ambient Temperature: $20 \pm 15^\circ\text{C}$
- b. Relative Humidity: $65\% \pm 20\%$
- c. Air Pressure: 86KPa to 106KPa

5.1.2 If any doubt on the results, measurements/tests should be made within the following limits:

- a. Ambient Temperature: $20 \pm 2^\circ\text{C}$
- b. Relative Humidity: $65\% \pm 5\%$
- c. Air Pressure: 86KPa to 106Kpa

5.2 Visual Examination

- a. Inspection Equipment: 10X magnifier

5.3 Electrical Test

5.3.1 Inductance (L)

- a. Refer to the third item.
- b. Test equipment: IM3536 LCR meter or equivalent.
- c. Test Frequency and Voltage: Refer to the third item.

5.3.2 Direct Current Resistance (DCR)

- a. Refer to the third item.
- b. Test equipment: VR126 or equivalent.

5.3.3 Saturation Current (I_{sat})

- a. Refer to the third item.
- b. Test equipment: Saturation current meter
- c. Definition of saturation current (I_{sat}): DC current at which the inductance drops approximate 40% from its value without current.

5.3.4 Temperature rise current (I_{rms})

- a. Refer to the third item.
- b. Test equipment (see Fig.5.3.4-1): Electric Power, Electric current meter, Thermometer.
- c. Measurement method (see Fig. 5.3.4-1):
 1. Set test current to be 0mA.
 2. Measure initial temperature of choke surface.
 3. Gradually increase current and measure choke temperature for corresponding current.
 4. Definition of Temperature rise current: DC current that causes the temperature rise ($\Delta T = 40^\circ\text{C}$) from 20°C ambient (see Fig. 5.3.4-2).

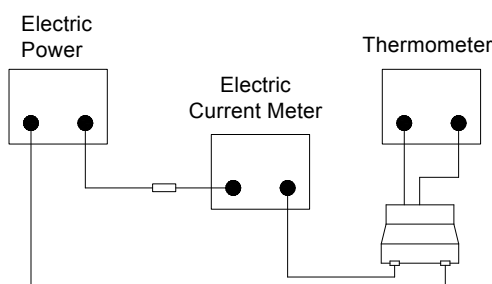

Fig.5.3.4-1

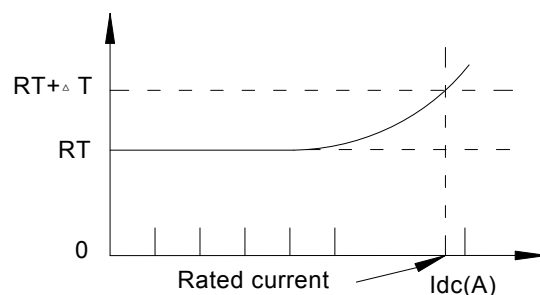
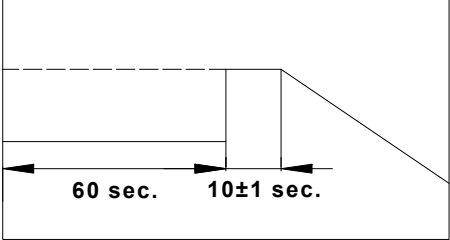
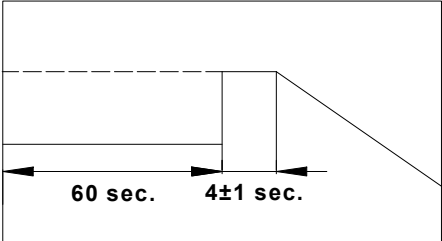

Fig.5.3.4-2

5.4 Reliability Test

Item	Specifications	Test conditions
5.4.1 High temperature storage test	No visible mechanical damage. Inductance change: Within $\pm 10\%$.	<p>Temperature: $125 \pm 2^\circ\text{C}$. Duration: 500hrs. Measured at room temperature after placing for 24 ± 4 hrs.</p>
5.4.2 Temperature cycling test	No visible mechanical damage. Inductance change: Within $\pm 10\%$.	<p>Condition for 1 cycle. Step1: $-40 \pm 2^\circ\text{C}$ 30min Min. Step2: $125 \pm 2^\circ\text{C}$, transition time 2min Max. Step3: $125 \pm 2^\circ\text{C}$ 30min Min. Step4: Low temp, transition time 2min Max. Number of cycles: 100. Measured at room temperature after placing for 24 ± 4 hrs.</p>
5.4.3 Biased humidity test	No visible mechanical damage. Inductance change: Within $\pm 10\%$.	<p>Humidity : $85\% \pm 3$ RH. Temperature: $60^\circ\text{C} \pm 2^\circ\text{C}$. Duration : 500hrs. Measured at room temperature after placing for 24 ± 4 hrs.</p>
5.4.4 Operational life test	No visible mechanical damage. Inductance change: Within $\pm 10\%$.	<p>Temperature: $85 \pm 2^\circ\text{C}$. Duration : 500hrs. Measured at room temperature after placing for 24 ± 4 hrs.</p>
5.4.5 Resistance to solvent test	No visible mechanical damage. Inductance change: Within $\pm 10\%$.	Add aqueous wash chemical - OKEM clean or equivalent.
5.4.6 Vibration test	No visible mechanical damage. Inductance change: Within $\pm 10\%$.	The sample shall be soldered onto the printed circuit board and when a vibration having an amplitude of 1.52mm and a frequency of from 10 to 55Hz/1 minute repeated should be applied to the 3 directions (X,Y,Z) for 2 hours each.(A total of 6 hours)

Item	Specifications	Test conditions
<p>5.4.7 Resistance to soldering heat test</p>	<p>No visible mechanical damage. Inductance change: Within $\pm 10\%$.</p>	<p>Temperature ($^{\circ}\text{C}$): 260 ± 5 (solder temp). Time (s): 10 ± 1. ramp/immersion and emersion rate: $25\text{mm/s} \pm 6 \text{ mm/s}$. Number of heat cycles:1.</p> 
<p>5.4.8 Solderability test</p>	<p>More than 95% of the terminal electrode should be covered with solder.</p>	<p>Steam Aging: 8 hours \pm 15 min. Preheat: 150°C, 60sec. Solder: Sn99.5%-Cu0. 5%. Temperature: $245 \pm 5^{\circ}\text{C}$. Flux for lead free: Rosin. 9.5%. Dip time: 4 ± 1sec. Depth: completely cover the termination.</p> 
<p>5.4.9 Terminal strength (SMD) test</p>	<p>No visible mechanical damage.</p>	<p>With the component mounted on a PCB with the device to be tested, apply a 10 N force to the side of a device being tested. This force shall be applied for 10 ± 1 seconds. Also the force shall be applied radually as not to apply a shock to the component being tested.</p>

6. Packaging, Storage

6.1 Tape and Reel Packaging Dimensions

6.1.1 Taping Dimensions (Unit: mm)

Please refer to Fig. 6.1.1-1

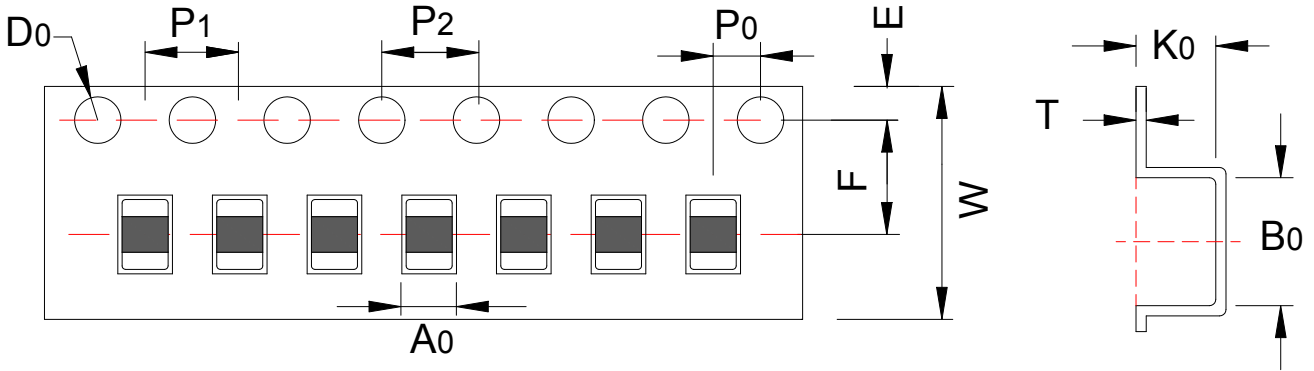

6.1.1-1

TYPE	A0	B0	W	E	F	P0	P1	P2	D0	T	K0
APS25T12	2.25±0.1	2.8±0.1	8.0±0.3	1.75±0.1	3.5±0.1	2.0±0.1	4.0±0.1	4.0±0.1	1.5±0.1	0.22±0.1	1.35±0.1

6.1.2 Reel Dimensions (Unit: mm)

Please refer to Fig. 6.1.2-1.

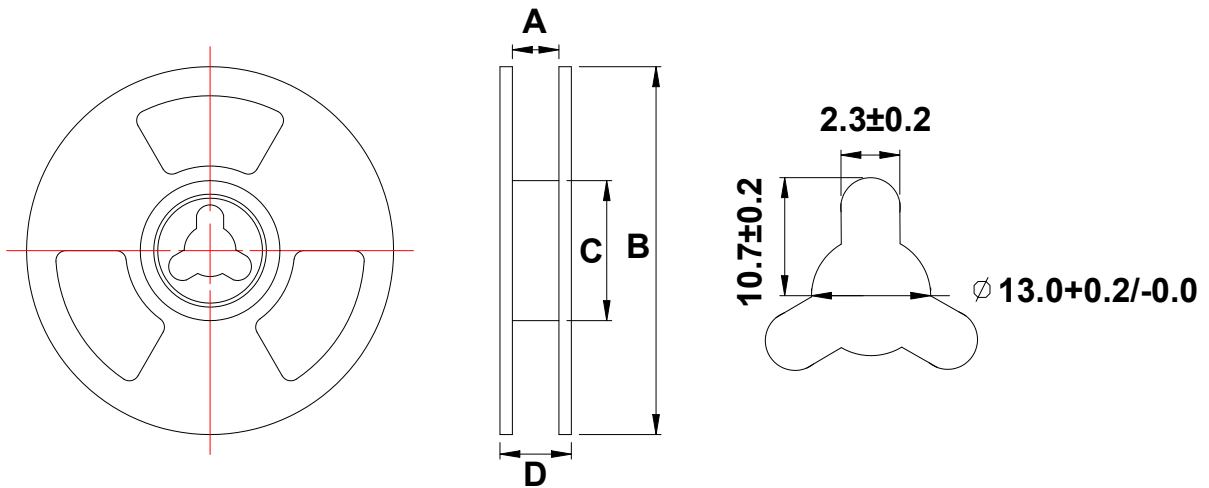

Fig. 6.1.2-1.

TYPE	A	B	C	D
APS25T12	9.0±2.0	178.0±2.0	58.0±2.0	11.0±2.0

6.2 Packaging

6.2.1 The inner box specification: 195*192*65MM

Packing quantity: 15000PCS/ box

Sealing bag: 32*23CM

Job description: putting the air sealing bag products placed inside the box.

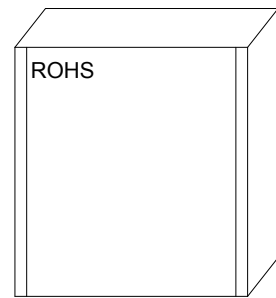

6.2.2 The outside box specification: 410*405*165MM

Packing quantity: 120000PCS/ box

Job description: will be outside the box bottom sealed, inner box into the box.

- a. With transparent tape sealed box at the top
- b. The specified location with a box labels in the outer box.
- c. If the mantissa box under a FCL with inner box for filling full

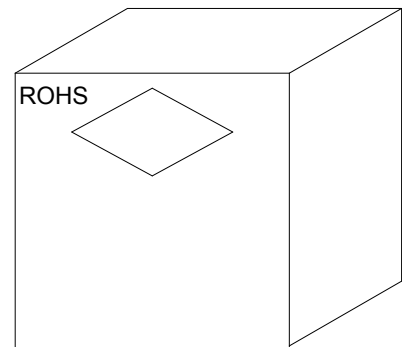

6.3 Storage

- a. To maintain the solderability of terminal electrodes and to keep the packing material in good condition, temperature and humidity in the storage area should be controlled.
- b. Recommended conditions: -10°C~40°C, 70%RH (Max.)
- c. Even under ideal storage conditions, solderability of products electrodes may decrease as time passes. For this reason, product should be used with one year from the time of delivery.
- d. In case of storage over one year, solderability shall be checked before actual usage.

7. Recommended Soldering Technologies

7.1 Re-flowing Profile:

- △ Preheat condition: 150~200°C/60~120sec.
- △ Allowed time above 217°C: 60~90sec.
- △ Max temp: 260°C
- △ Max time at max temp: 5sec.
- △ Solder paste: Sn/3.0Ag/0.5Cu
- △ Allowed Reflow time: 2x max

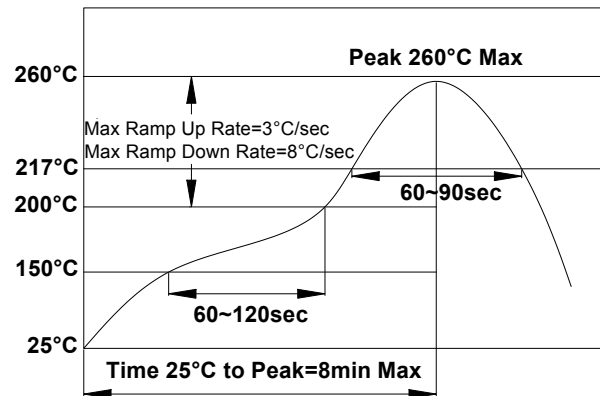

7.2 Iron Soldering Profile:

- △ Iron soldering power: Max.30W
- △ Pre-heating: 150°C/60sec.
- △ Soldering Tip temperature: 350°C Max.
- △ Soldering time: 3sec Max.
- △ Solder paste: Sn/3.0Ag/0.5Cu
- △ Max.1 times for iron soldering

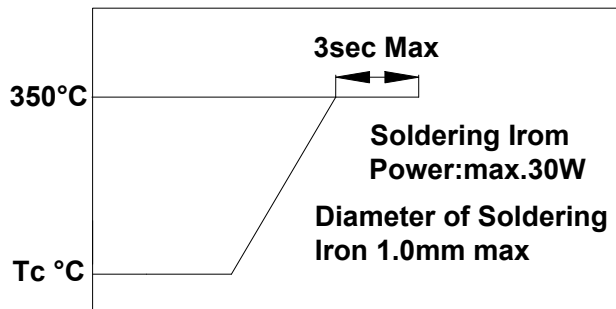

[Note: Take care not to apply the tip of the soldering iron to the]