

THIS DRAWING IS UNPUBLISHED. RELEASED FOR PUBLICATION  
 © COPYRIGHT - By - ALL RIGHTS RESERVED.

LOC	DIST	REVISIONS					
		P	LTR	DESCRIPTION	DATE	DWN	APVD
G	14		K1	REVISED PER ECO-13-005146	22MAR13	KH	DR

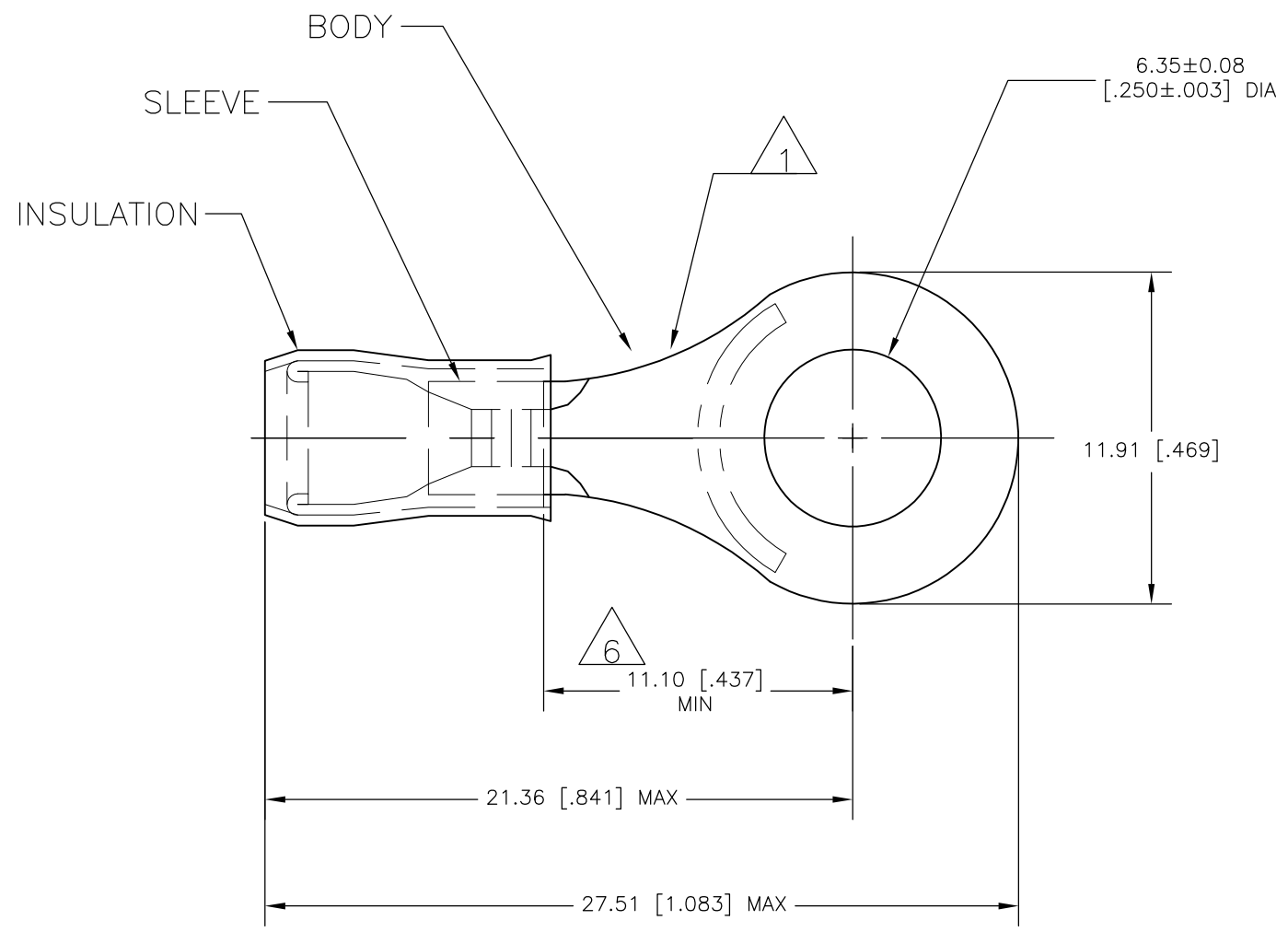

- ① STAMP AMP 16-14\* APPROX AS SHOWN
- 2 WIRE INSULATION DIA: 2.7-3.8 [.105-.150]
- 3 TONGUE MATERIAL THK: 0.78±0.05 [.031±.002]
- ④ BODY & SLEEVE: TIN PLATE PER ASTM B545,
- ⑤ BODY & SLEEVE- CU PER ASTM B152 INSULATION - NYLON, COLOR - BLUE
- ⑥ APPLIES FROM EDGE OF METAL WIRE BARREL TO CENTER OF STUD HOLE.

OBSOLETE	5000	ON TAPE	2-130114-1
	1000	LOOSE PIECE	130114
	QTY	PACKAGE TYPE	PART NO

AMP INCORPORATED CUSTOMER SERVICE SYSTEMS		MAX RECOMMENDED OPERATING TEMPERATURE: 150°C [302°F] MAX	THIS DRAWING IS A CONTROLLED DOCUMENT.		DWN JR RUTH 12NOV07	<b>STE</b> TE Connectivity
FOR ADDITIONAL PRODUCT INFORMATION OR COPIES OF DRAWINGS AND TECHNICAL DOCUMENTS	PRODUCT INFORMATION CENTER 1-800-522-6752	VOLTAGE RATING: -	DIMENSIONS: mm [INCHES]	TOLERANCES UNLESS OTHERWISE SPECIFIED:	CHK T MICHELUTTI 12NOV07	
FOR APPLICATION TOOLING INFORMATION	TOOLING ASSISTANCE CENTER 1-800-722-1111	CIRCULAR MIL AREA: 1.04-2.62mm² [2,050-5,180] STRANDED		0 PLC ± - 1 PLC ± - 2 PLC ± - 3 PLC ± - 4 PLC ± - ANGLES ± -	APVD T MICHELUTTI 12NOV07	NAME TERMINAL, RING TONGUE, P.I.D.G. WIRE SIZE: 16-14 AWG
FOR ORDER ENTRY	1-800-526-5142		MATERIAL ⑤	FINISH ④	PRODUCT SPEC -	SIZE A3
			CUSTOMER DRAWING		WEIGHT -	CAGE CODE 00779
					DRAWING NO C-130114	RESTRICTED TO -
					SCALE 4:1	SHEET 1 OF 1
					REV K1	