

CHARACTERISTICS

MATERIALS

HOUSING : BRASS
 HOUSING PLATING : 196µ" NICKEL MIN.
 SHELL & COLLET NUT: BRASS, 196µ" CHROME PLATED MIN.
 CONTACTS : COPPER ALLOY
 CONTACT PLATING : 7µ" GOLD PLATED OVER 196µ" NICKEL MIN.
 INSULATOR : PPS (HIGH TEMPERATURE)
 STRAIN RELIEF(BOOT) : THERMOPLASTIC POLYURETHANE
 O-RING: SILICONE

MECHANICAL

DURABILITY: 5000 CYCLES
 OPERATING TEMP. RANGE: -40°C ~ +200°C
 PROCESS TEMPERATURE : 260°C FOR 5 SECONDS
 MAX. TORQUE VALUE : 0.8 Nm [7.0 IN/LBS]
 SHIELDING: 75dB @ 10MHz
 40dB @ 1GHz

IP RATING: 67

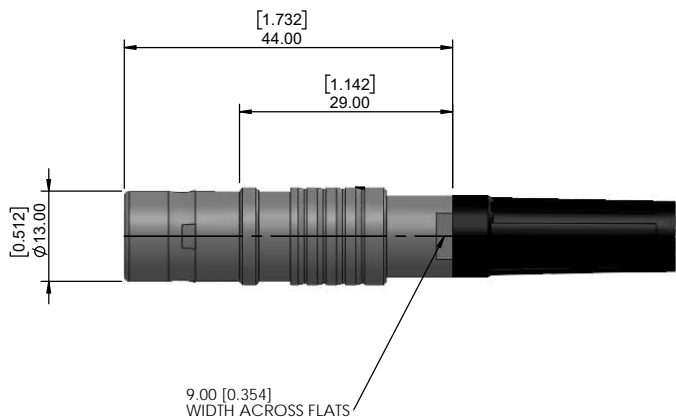

CHART B

COLLET SIZE	WIRE DIAMETER
40	3.30 [0.130] ~ 4.20 [0.165]
50	4.30 [0.169] ~ 5.20 [0.205]
60	5.30 [0.209] ~ 6.20 [0.244]

CHART A

● = KEY LOCATION

VIEW FROM TERMINATION END

 2 POSITION 20 AWG MAX. 15 AMP MAX. PIN Ø = 1.30 [0.051]	 3 POSITION 20 AWG MAX. 12 AMP MAX. PIN Ø = 1.30 [0.051]	 4 POSITION 22 AWG MAX. 10 AMP MAX. PIN Ø = 0.90 [0.035]	 5 POSITION 22 AWG MAX. 9 AMP MAX. PIN Ø = 0.90 [0.035]	 6 POSITION 24 AWG MAX. 7 AMP MAX. PIN Ø = 0.70 [0.028]	 7 POSITION 24 AWG MAX. 7 AMP MAX. PIN Ø = 0.70 [0.028]	 14 POSITION 28 AWG MAX. 2 AMP MAX. PIN Ø = 0.50 [0.020]
CONTACT RESISTANCE = 5 mΩ TEST VOLTAGE = 1500V WORKING VOLTAGE = 500V	CONTACT RESISTANCE = 5 mΩ TEST VOLTAGE = 1300V WORKING VOLTAGE = 430V	CONTACT RESISTANCE = 6 mΩ TEST VOLTAGE = 1300V WORKING VOLTAGE = 430V	CONTACT RESISTANCE = 6 mΩ TEST VOLTAGE = 1250V WORKING VOLTAGE = 415V	CONTACT RESISTANCE = 7.5 mΩ TEST VOLTAGE = 1050V WORKING VOLTAGE = 350V	CONTACT RESISTANCE = 7.5 mΩ TEST VOLTAGE = 950V WORKING VOLTAGE = 315V	CONTACT RESISTANCE = 10 mΩ TEST VOLTAGE = 800V WORKING VOLTAGE = 267V

RoHS COMPLIANT



THESE DRAWINGS AND SPECIFICATIONS ARE THE PROPERTY OF NorComp AND SHALL NOT BE REPRODUCED, COPIED OR USED AS THE BASIS FOR THE MANUFACTURE OR SALE OF APPARATUS WITHOUT WRITTEN PERMISSION.

NorComp

DRAWN: M. SIGMON

DATE: 02-19-16

SCALE: N.T.S.

SHEET 1 OF 1

REV: 6

DWG NO. 821KYYY-173LYY1

Mouser Electronics

Authorized Distributor

Click to View Pricing, Inventory, Delivery & Lifecycle Information:

NorComp:

<u>821K005-173L501</u>	<u>821K007-173L401</u>	<u>821K006-173L401</u>	<u>821K004-173L601</u>	<u>821K006-173L601</u>	<u>821K006-173L501</u>
<u>821K002-173L501</u>	<u>821K004-173L501</u>	<u>821K003-173L601</u>	<u>821K007-173L501</u>	<u>821K002-173L601</u>	<u>821K007-173L601</u>
<u>821K003-173L401</u>	<u>821K003-173L501</u>	<u>821K004-173L401</u>	<u>821K005-173L401</u>	<u>821K002-173L401</u>	<u>821K005-173L601</u>