

规格书编号

SPEC NO :

产品规格书

SPECIFICATION

CUSTOMER 客户: _____
PRODUCT 产品: _____ SAW RESONATOR _____
MODEL NO 型号: _____ HDR315M2 S6 _____
PREPARED 编制: _____ CHECKED 审核: _____
APPROVED 批准: _____ D A T E 日期: _____ 2011-5-25 _____

客户确认 CUSTOMER RECEIVED:		
审核 CHECKED	批准 APPROVED	日期 DATE

无锡市好达电子有限公司
Shoulder Electronics Limited

更改历史记录 History Record

更改日期 Date	规格书编号 Spec. No.	产品型号 Part No.	客户产品型号 Customer No.	更改内容描述 Modify Content	备注 Remark

1. Scope

This specification shall cover the characteristics of 1-port SAW resonator with R315M2 used for remote-control security.

2. Electrical Specification

2.1 Maximum Rating

DC Voltage VDC	10V
AC Voltage Vpp	10V 50Hz/60Hz
Operation temperature	-40°C to +85°C
Storage temperature	-45°C to +85°C
Source Power	0dBm

2.2 Electronic Characteristics

Item	Unites	Minimum	Typical	Maximum
Center Frequency	MHz	314.925	315.000	315.075
Insertion Loss	dB		1.4	1.9
Quality Factor	Unload Q	8000	12800	
	50Ω Loaded Q	1000	2000	
Temperature Stability	Turnover Temperature	°C	10	25
	Freq.temp.Coefficient	ppm/°C		0.032
Frequency Aging	ppm/yr		<±10	
DC. Insulation Resistance	MΩ	1.0		
RF Equivalent RLC Model	Motional Resistance R1	Ω	17.6	
	Motional Inductance L1	μH	118	
	Motional Capacitance C1	fF	2.16	
Transducer Static Capacitance C0	pF		2.13	

2.3 Equivalent LC Model

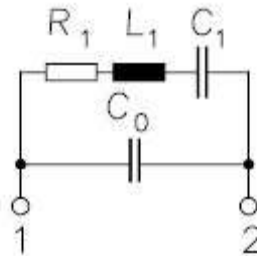

3. Test Circuit

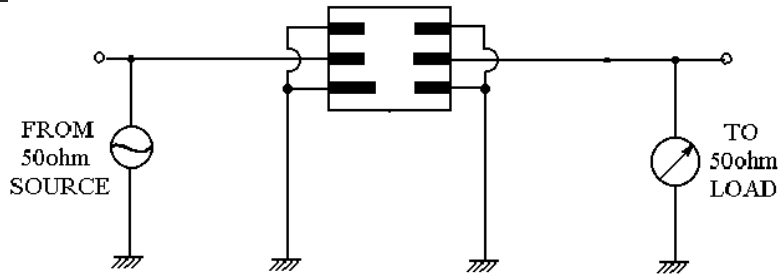

4. Dimension

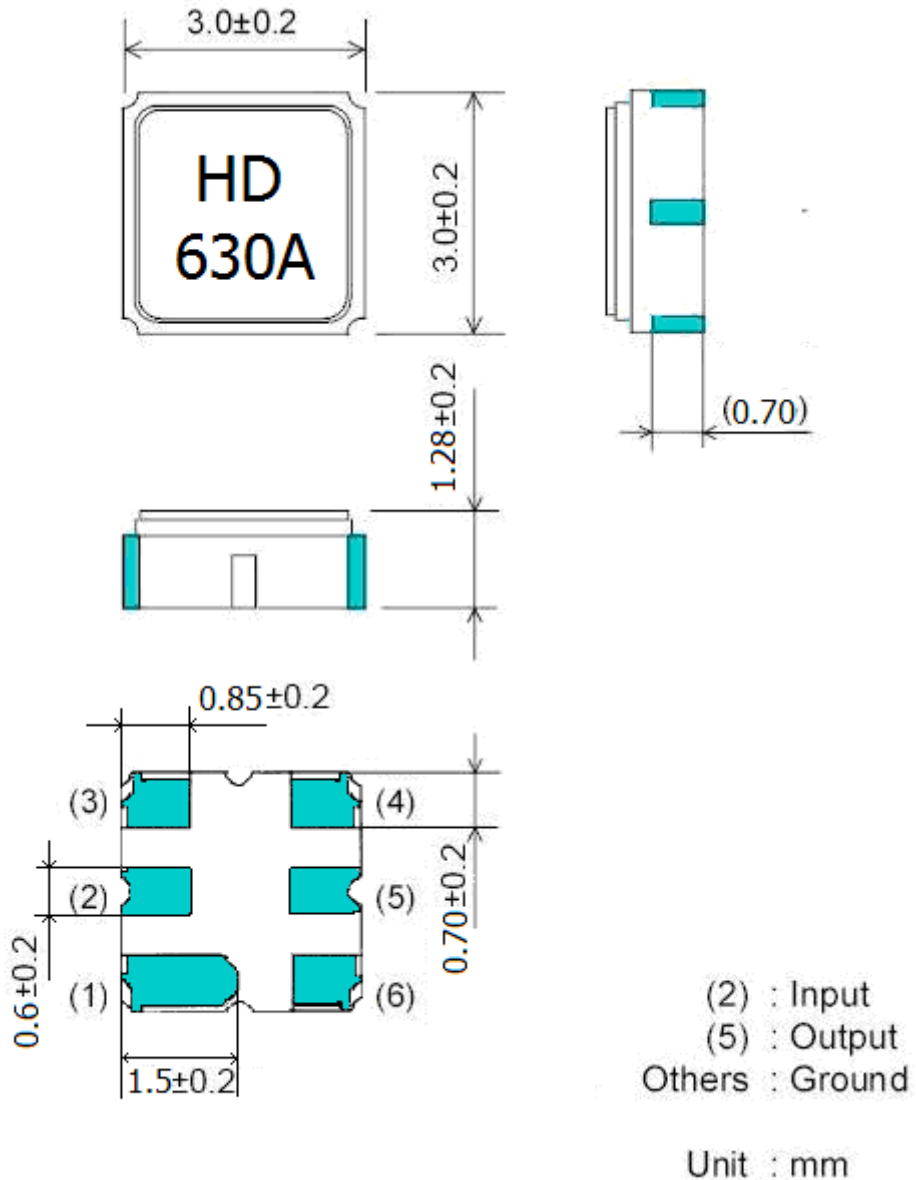

- 1. **HD**: Manufacture's logo
- 2. 630A: Model code

5. Environment Characteristic

5-1 Thermal Shock:

The components shall remain within the electrical specifications after being kept at the condition of heat cycle conditions: $T_A = -40^{\circ}\text{C} \pm 3^{\circ}\text{C}$, $T_B = 85^{\circ}\text{C} \pm 2^{\circ}\text{C}$, $t_1 = t_2 = 30\text{min}$, switch time $\leq 3\text{min}$ & cycle time : 100 times, recovery time: $2\text{h} \pm 0.5\text{h}$.

5-2 Resistance to solder heat

Submerge the device terminals into the solder bath at $260^{\circ}\text{C} \pm 5^{\circ}\text{C}$ for 10 ± 1 sec. Then release the device into the room conditions for 4 hours. It shall meet the specifications in 2.2.

5-3 Solder ability

Submerge the device terminals into the solder bath at $245^{\circ}\text{C} \pm 5^{\circ}\text{C}$ for 5s, More than 95% area of the soldering pad must be covered with new solder. It shall meet the specifications in 2.2

5-4 The Temperature Storage:

5.3.1 High Temperature Storage: The components shall remain within the electrical specifications after being kept at the $85^{\circ}\text{C} \pm 2^{\circ}\text{C}$ for $96\text{h} \pm 4\text{h}$, recovery time : $2\text{h} \pm 0.5\text{h}$.

5.3.2 Low Temperature Storage: The components shall remain within the electrical specifications after being kept at the $-40^{\circ}\text{C} \pm 3^{\circ}\text{C}$ for $96\text{h} \pm 4\text{h}$, recovery time : $2\text{h} \pm 0.5\text{h}$.

5-5 Humidity test:

The components shall remain within the electrical specifications after being kept at the condition of ambient temperature $60^{\circ}\text{C} \pm 2^{\circ}\text{C}$, and 90~96% RH for $96\text{h} \pm 4\text{h}$.

5-6 Mechanical shock

Drop the device randomly onto the concrete floor from the height of 1m for 3 times. The resonator shall fulfill the specifications in 2.2.

5-7 Vibration

Subject the device to the vibration for 2 hour each in X, Y and Z axes with the amplitude of 1.5 mm at 10 to 55 Hz. The resonator shall fulfill the specifications in 2.2.

6. Remark

6.1 Static voltage

Static voltage between signal load & ground may cause deterioration & destruction of the component. Please avoid static voltage.

6.2 Ultrasonic cleaning

Ultrasonic vibration may cause deterioration & destruction of the component. Please avoid ultrasonic cleaning

6.3 Soldering

Only leads of component may be soldered. Please avoid soldering another part of component.

7. Packing

7.1 Dimensions

- (1) Carrier Tape: Figure 1
- (2) Reel: Figure 2
- (3) The product shall be packed properly not to be damaged during transportation and storage.

7.2 Reeling Quantity

- 1000 pcs/reel 7"
- 3000 pcs/reel 13"

7.3 Taping Structure

- (1) The tape shall be wound around the reel in the direction shown below.

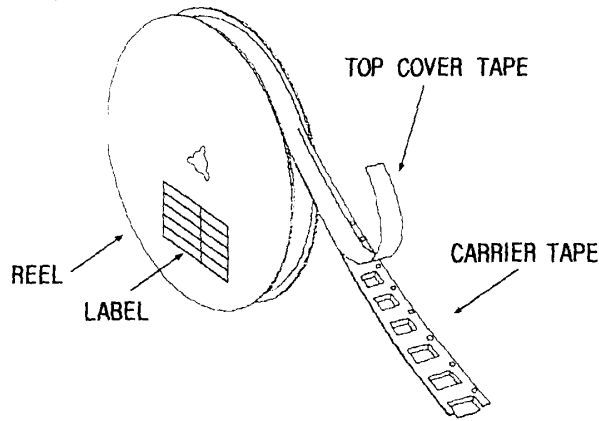

- (2) Label

Device Name	
User Product Name	
Quantity	
Lot No.	

- (3) Leader part and vacant position specifications.

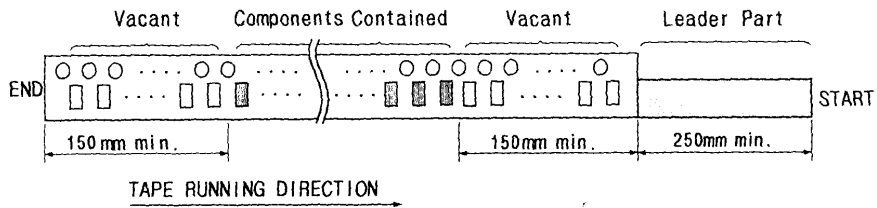

8. Tape Specifications

8.1 Tensile Strength of Carrier Tape: 4.4N/mm width

8.2 Top Cover Tape Adhesion (See the below figure)

- (1) pull off angle: 0~15°
- (2) speed: 300mm/min.
- (3) force: 20~70g

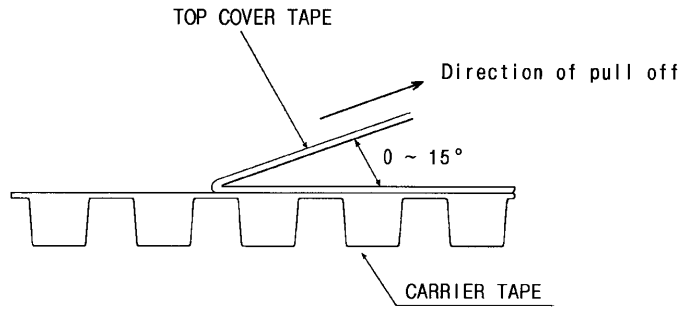

[Figure 1] Carrier Tape Dimensions

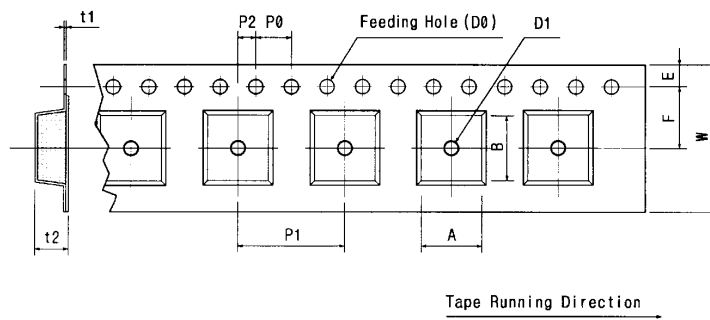

[Unit: mm]

W	F	E	P0	P1	P2	D0	D1	t1	t2	A	B
12.0	5.5	1.75	4.0	4.0	2.0	Ø1.5	Ø1.0	0.3	1.25	3.3±	3.3±
±0.3	±0.05	±0.1	±0.1	±0.1	±0.05	±0.1	±0.25	±0.05	±0.1	0.1	0.1

[Figure 2] Reel Dimensions

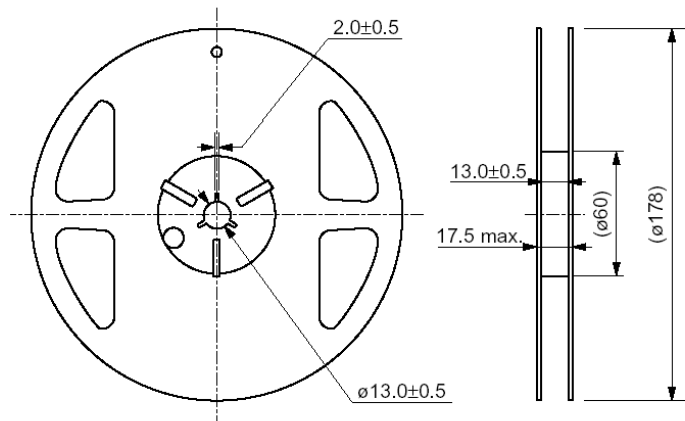

Ø178 Reel Dimension

(in mm)

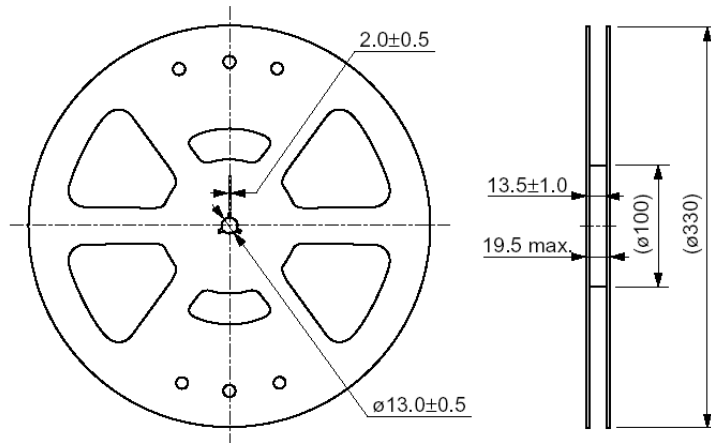

Ø330 Reel Dimension

(in mm)