

Features

- Epitaxial Planar Die Construction
- One Transistor and One Switching Diode in One Package
- Lead Free By Design/RoHS Compliant (Note 1)
- "Green" Device (Note 2)

Mechanical Data

- Case: SOT-363
- Case Material: Molded Plastic. "Green" Molding Compound. UL Flammability Classification Rating 94V-0
- Moisture Sensitivity: Level 1 per J-STD-020D
- Terminal Connections: See Diagram
- Terminals: Finish - Matte Tin annealed over Alloy 42 leadframe. Solderable per MIL-STD-202, Method 208
- Marking Information: See Page 8
- Ordering Information: See Page 8
- Weight: 0.008 grams (approximate)

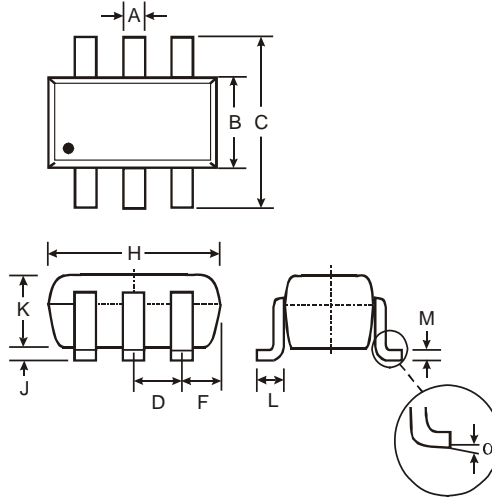

SOT-363		
Dim	Min	Max
A	0.10	0.30
B	1.15	1.35
C	2.00	2.20
D	0.65 Nominal	
F	0.30	0.40
H	1.80	2.20
J	—	0.10
K	0.90	1.00
L	0.25	0.40
M	0.10	0.25
α	0°	8°

All Dimensions in mm

P/N	R1 (NOM)	R2 (NOM)
DRDNB16W	1K	10K
DRDPB16W	1K	10K
DRDNB26W	220	4.7K
DRDPB26W	220	4.7K

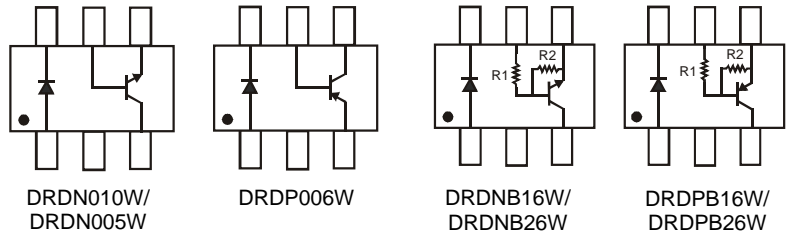

Maximum Ratings, Total Device @T_A = 25°C unless otherwise specified

Characteristic	Symbol	Value	Unit
Power Dissipation (Note 3)	P _D	200	mW
Thermal Resistance, Junction to Ambient Air (Note 3)	R _{θJA}	625	°C/W
Operating and Storage Temperature Range	T _J , T _{STG}	-55 to +150	°C

Maximum Ratings, DRDN010W NPN Transistor @T_A = 25°C unless otherwise specified

Characteristic	Symbol	Value	Unit
Collector-Base Voltage	V _{CBO}	45	V
Collector-Emitter Voltage	V _{CEO}	18	V
Emitter-Base Voltage	V _{EBO}	5	V
Collector Current (Note 3)	I _C	1000	mA

Maximum Ratings, DRDN005W NPN Transistor @T_A = 25°C unless otherwise specified

Characteristic	Symbol	Value	Unit
Collector-Base Voltage	V _{CBO}	80	V
Collector-Emitter Voltage	V _{CEO}	80	V
Emitter-Base Voltage	V _{EBO}	4.0	V
Collector Current – Continuous (Note 3)	I _C	500	mA

- Notes:
1. No purposefully added lead.
 2. Diodes Inc.'s "Green" policy can be found on our website at http://www.diodes.com/products/lead_free/index.php.
 3. Device mounted on FR-4 PCB, 1 inch x 0.85 inch x 0.062 inch; pad layout as shown on Diodes Inc. suggested pad layout document AP02001, which can be found on page 9 or our website at <http://www.diodes.com/datasheets/ap02001.pdf>.



Maximum Ratings, DRDP006W PNP Transistor @T_A = 25°C unless otherwise specified

Characteristic	Symbol	Value	Unit
Collector-Base Voltage	V _{CBO}	-60	V
Collector-Emitter Voltage	V _{CEO}	-60	V
Emitter-Base Voltage	V _{EB0}	-5.0	V
Collector Current (Note 3)	I _C	-600	mA

Maximum Ratings, DRDNB16W Pre-Biased NPN Transistor @T_A = 25°C unless otherwise specified

Characteristic	Symbol	Value	Unit
Supply Voltage	V _{CC}	50	V
Input Voltage	V _{IN}	-5 to +10	V
Output Current	I _C	600	mA

Maximum Ratings, DRDNB26W Pre-Biased NPN Transistor @T_A = 25°C unless otherwise specified

Characteristic	Symbol	Value	Unit
Supply Voltage	V _{CC}	50	V
Input Voltage	V _{IN}	-5 to +5	V
Output Current	I _C	600	mA

Maximum Ratings, DRDPB16W Pre-Biased PNP Transistor @T_A = 25°C unless otherwise specified

Characteristic	Symbol	Value	Unit
Supply Voltage	V _{CC}	-50	V
Input Voltage	V _{IN}	+5 to -10	V
Output Current	I _C	600	mA

Maximum Ratings, DRDPB26W Pre-Biased PNP Transistor @T_A = 25°C unless otherwise specified

Characteristic	Symbol	Value	Unit
Supply Voltage	V _{CC}	-50	V
Input Voltage	V _{IN}	+5 to -5	V
Output Current	I _C	-600	mA

Maximum Ratings, Switching Diode @T_A = 25°C unless otherwise specified

Characteristic	Symbol	Value	Unit
Non-Repetitive Peak Reverse Voltage	V _{RM}	100	V
Peak Repetitive Reverse Voltage	V _{R(RM)}	75	V
Working Peak Reverse Voltage	V _{R(WM)}		
DC Blocking Voltage	V _R		
RMS Reverse Voltage	V _{R(RMS)}	53	V
Forward Continuous Current (Note 3)	I _{FM}	500	mA
Average Rectified Output Current (Note 3)	I _O	250	mA
Non-Repetitive Peak Forward Surge Current	I _{FSM}	@ t = 1.0μs	4.0
		@ t = 1.0s	2.0



Electrical Characteristics, DRDN010W NPN Transistor @T_A = 25°C unless otherwise specified

Characteristic	Symbol	Min	Max	Unit	Test Condition
DC Current Gain	h_{FE}	150	800	—	$I_C = 100\text{mA}$, $V_{CE} = 1\text{V}$
Collector-Emitter Saturation Voltage	$V_{CE(SAT)}$	—	0.5	V	$I_C = 300\text{mA}$, $I_B = 30\text{mA}$
Collector-Base Breakdown Voltage	$V_{(BR)CBO}$	45	—	V	$I_C = 100\mu\text{A}$, $I_E = 0$
Collector-Emitter Breakdown Voltage	$V_{(BR)CEO}$	18	—	V	$I_C = 1\text{mA}$, $I_B = 0$
Emitter-Base Breakdown Voltage	$V_{(BR)EBO}$	5	—	V	$I_E = 100\mu\text{A}$, $I_C = 0$
Collector Cutoff Current	I_{CBO}	—	1	μA	$V_{CB} = 40\text{V}$, $I_E = 0$
Emitter Cutoff Current	I_{EBO}	—	1	μA	$V_{EB} = 4\text{V}$, $I_C = 0$
Current Gain-Bandwidth Product	f_T	100	—	MHz	$V_{CE} = 10\text{V}$, $I_C = 50\text{mA}$, $f = 100\text{MHz}$
Capacitance	C_{obo}	—	8	pF	$V_{CB} = 10\text{V}$, $I_E = 0$, $f = 1\text{MHz}$

Electrical Characteristics, DRDN005W NPN Transistor @T_A = 25°C unless otherwise specified

Characteristic	Symbol	Min	Max	Unit	Test Condition
Collector-Base Breakdown Voltage	$V_{(BR)CBO}$	80	—	V	$I_C = 100\mu\text{A}$, $I_E = 0$
Collector-Emitter Breakdown Voltage	$V_{(BR)CEO}$	80	—	V	$I_C = 1.0\text{mA}$, $I_B = 0$
Emitter-Base Breakdown Voltage	$V_{(BR)EBO}$	4.0	—	V	$I_E = 100\mu\text{A}$, $I_C = 0$
Collector Cutoff Current	I_{CBO}	—	100	nA	$V_{CB} = 60\text{V}$, $I_E = 0$ $V_{CB} = 80\text{V}$, $I_E = 0$
Collector Cutoff Current	I_{CES}	—	100	nA	$V_{CE} = 60\text{V}$, $I_{BO} = 0\text{V}$ $V_{CE} = 80\text{V}$, $I_{BO} = 0\text{V}$
DC Current Gain	h_{FE}	100	—	—	$I_C = 10\text{mA}$, $V_{CE} = 1.0\text{V}$ $I_C = 100\text{mA}$, $V_{CE} = 1.0\text{V}$
Collector-Emitter Saturation Voltage	$V_{CE(SAT)}$	—	0.25	V	$I_C = 100\text{mA}$, $I_B = 10\text{mA}$
Base-Emitter Saturation Voltage	$V_{BE(SAT)}$	—	1.2	V	$I_C = 100\text{mA}$, $V_{CE} = 1.0\text{V}$
Current Gain-Bandwidth Product	f_T	100	—	MHz	$V_{CE} = 2.0\text{V}$, $I_C = 10\text{mA}$, $f = 100\text{MHz}$

Electrical Characteristics, DRDP006W PNP Transistor @T_A = 25°C unless otherwise specified

Characteristic	Symbol	Min	Max	Unit	Test Condition
DC Current Gain	h_{FE}	100	300	—	$I_C = -150\text{mA}$, $V_{CE} = -10\text{V}$
Collector-Emitter Saturation Voltage	$V_{CE(SAT)}$	—	-0.4	V	$I_C = -150\text{mA}$, $I_B = -15\text{mA}$
Collector-Base Breakdown Voltage	$V_{(BR)CBO}$	-60	—	V	$I_C = -10\mu\text{A}$, $I_E = 0$
Collector-Emitter Breakdown Voltage	$V_{(BR)CEO}$	-60	—	V	$I_C = -10\text{mA}$, $I_B = 0$
Emitter-Base Breakdown Voltage	$V_{(BR)EBO}$	-5	—	V	$I_E = -10\mu\text{A}$, $I_C = 0$
Collector Cutoff Current	I_{CBO}	—	-10	nA	$V_{CB} = -50\text{V}$, $I_E = 0$
Current Gain-Bandwidth Product	f_T	200	—	MHz	$V_{CE} = -20\text{V}$, $I_C = -50\text{mA}$, $f = 100\text{MHz}$
Capacitance	C_{obo}	—	8	pF	$V_{CB} = -10\text{V}$, $I_E = 0$, $f = 1\text{MHz}$

Electrical Characteristics, DRDNB16W Pre-Biased NPN Transistor @T_A = 25°C unless otherwise specified

Characteristic	Symbol	Min	Typ	Max	Unit	Test Condition
Input Voltage	$V_{I(off)}$	0.3	—	—	V	$V_{CC} = 5\text{V}$, $I_O = 100\mu\text{A}$
	$V_{I(on)}$	—	—	2.0	V	$V_O = 0.3\text{V}$, $I_O = 20\text{mA}$
Output Voltage	$V_{O(on)}$	—	—	0.3V	V	$I_O/I_I = 50\text{mA}/2.5\text{mA}$
Input Current	I_I	—	—	7.2	mA	$V_I = 5\text{V}$
Output Current	$I_{O(off)}$	—	—	0.5	μA	$V_{CC} = 50\text{V}$, $V_I = 0\text{V}$
DC Current Gain	G_I	56	—	—	—	$V_O = 5\text{V}$, $I_O = 50\text{mA}$
Gain-Bandwidth Product	f_T	—	200	—	MHz	$V_{CE} = 10\text{V}$, $I_E = 5\text{mA}$, $f = 100\text{MHz}$



Electrical Characteristics, DRDNB26W Pre-Biased NPN Transistor @T_A = 25°C unless otherwise specified

Characteristic	Symbol	Min	Typ	Max	Unit	Test Condition
Input Voltage	V _{I(off)}	0.5	—	—	V	V _{CC} = 5V, I _O = 100μA
	V _{I(on)}	—	—	3.0	V	V _O = 0.3V, I _O = 20mA
Output Voltage	V _{O(on)}	—	—	0.3V	V	I _O /I _I = 50mA/2.5mA
Input Current	I _I	—	—	28	mA	V _I = 5V
Output Current	I _{O(off)}	—	—	0.5	μA	V _{CC} = 50V, V _I = 0V
DC Current Gain	G _I	47	—	—	—	V _O = 5V, I _O = 50mA
Gain-Bandwidth Product	f _T	—	200	—	MHz	V _{CE} = 10V, I _E = 5mA, f = 100MHz

Electrical Characteristics, DRDPB16W Pre-Biased PNP Transistor @T_A = 25°C unless otherwise specified

Characteristic	Symbol	Min	Typ	Max	Unit	Test Condition
Input Voltage	V _{I(off)}	-0.3	—	—	V	V _{CC} = -5V, I _O = -100μA
	V _{I(on)}	—	—	-2.0	V	V _O = -0.3V, I _O = -20mA
Output Voltage	V _{O(on)}	—	—	-0.3V	V	I _O /I _I = -50mA/-2.5mA
Input Current	I _I	—	—	-7.2	mA	V _I = -5V
Output Current	I _{O(off)}	—	—	-0.5	μA	V _{CC} = -50V, V _I = 0V
DC Current Gain	G _I	56	—	—	—	V _O = -5V, I _O = -50mA
Gain-Bandwidth Product	f _T	—	200	—	MHz	V _{CE} = -10V, I _E = -5mA, f = 100MHz

Electrical Characteristics, DRDPB26W Pre-Biased PNP Transistor @T_A = 25°C unless otherwise specified

Characteristic	Symbol	Min	Typ	Max	Unit	Test Condition
Input Voltage	V _{I(off)}	-0.5	—	—	V	V _{CC} = -5V, I _O = -100μA
	V _{I(on)}	—	—	-3.0	V	V _O = -0.3V, I _O = -20mA
Output Voltage	V _{O(on)}	—	—	-0.3V	V	I _O /I _I = -50mA/-2.5mA
Input Current	I _I	—	—	-28	mA	V _I = -5V
Output Current	I _{O(off)}	—	—	-0.5	μA	V _{CC} = -50V, V _I = 0V
DC Current Gain	G _I	47	—	—	—	V _O = -5V, I _O = -50mA
Gain-Bandwidth Product	f _T	—	200	—	MHz	V _{CE} = -10V, I _E = -5mA, f = 100MHz

Electrical Characteristics, Switching Diode @T_A = 25°C unless otherwise specified

Characteristic	Symbol	Min	Max	Unit	Test Condition
Reverse Breakdown Voltage (Note 4)	V _{(BR)R}	75	—	—	I _R = 10μA
Forward Voltage	V _F	0.62	0.72	V	I _F = 5.0mA
		—	0.855		I _F = 10mA
		—	1.0		I _F = 100mA
		—	1.25		I _F = 150mA
Reverse Current (Note 4)	I _R	—	2.5	μA	V _R = 75V
			50	μA	V _R = 75V, T _J = 150°C
			30	μA	V _R = 25V, T _J = 150°C
			25	nA	V _R = 20V
Total Capacitance	C _T	—	4.0	pF	V _R = 0, f = 1.0MHz
Reverse Recovery Time	t _{rr}	—	4.0	ns	I _F = I _R = 10mA, I _{rr} = 0.1 x I _R , R _L = 100Ω

Notes: 4. Short duration pulse test used to minimize self-heating effect.

Device Characteristics

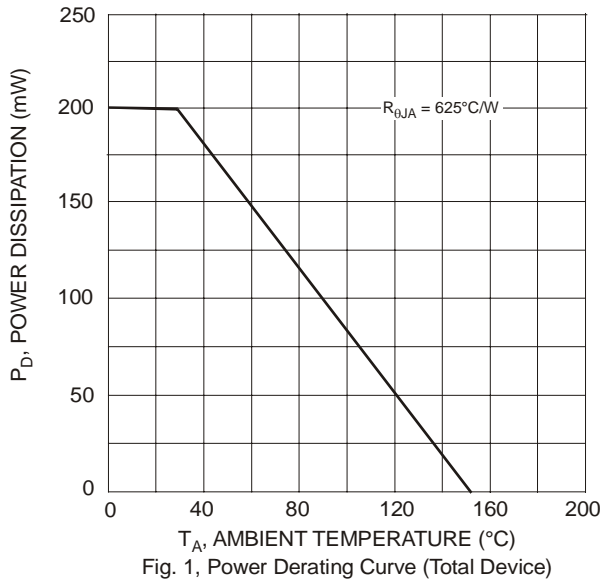

Fig. 1, Power Derating Curve (Total Device)

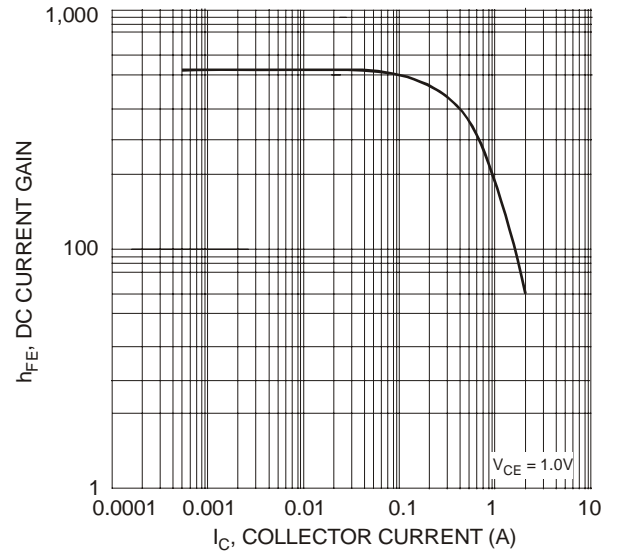

Fig. 2, Typical DC Current Gain vs. Collector Current (DRDN010W)

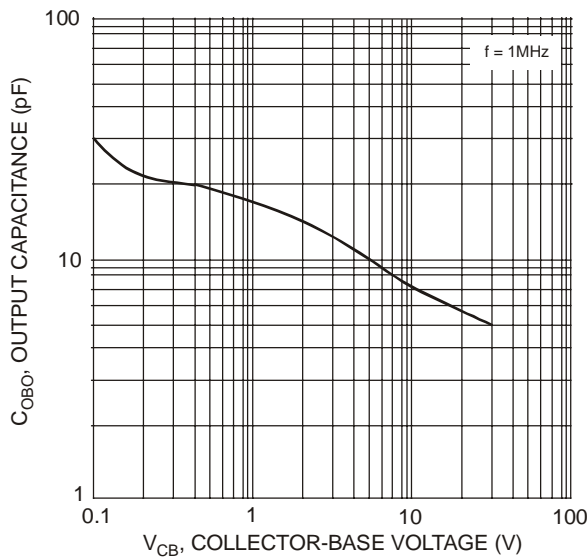

Fig. 3, Typical Output Capacitance vs. Collector-Base Voltage (DRDN010W)

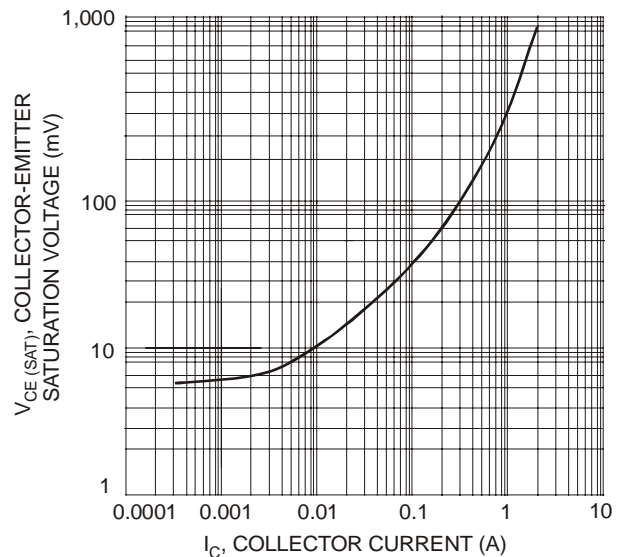

Fig. 4, Typical Collector Saturation Voltage vs. Collector Current (DRDN010W)

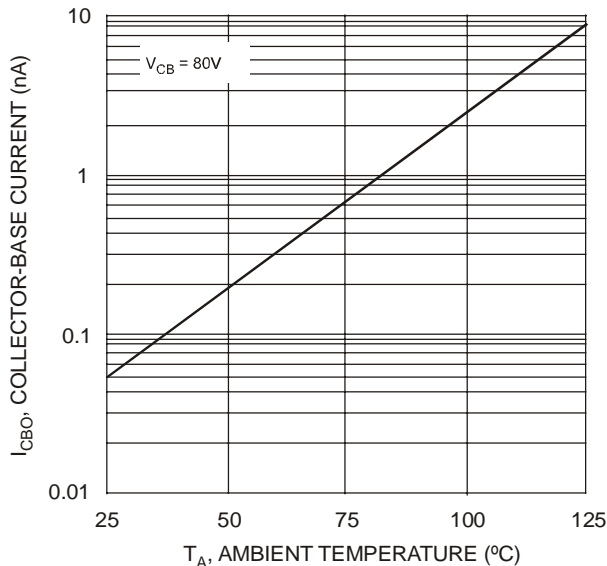

Fig. 5, Typical Collector-Cutoff Current vs. Ambient Temperature (DRDN005W)

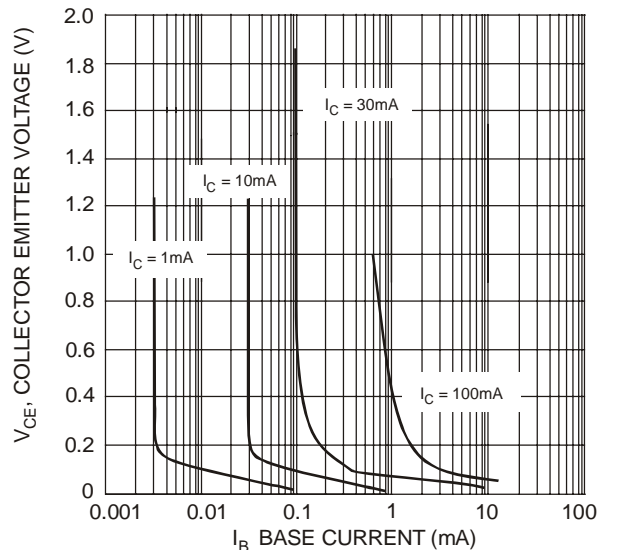

Fig. 6, Typical Collector Saturation Region (DRDN005W)

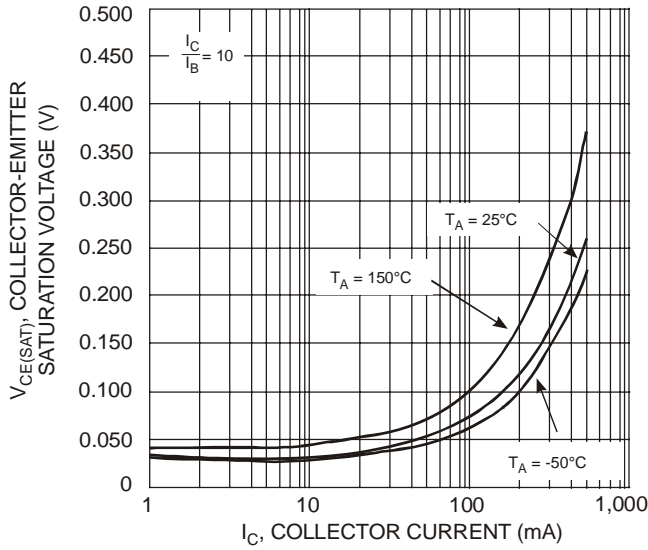

Fig. 7, Typical Collector-Emitter Saturation Voltage vs. Collector Current (DRDN005W)

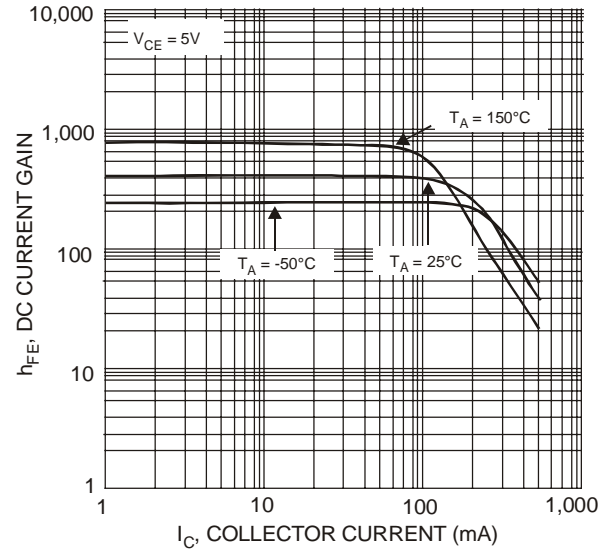

Fig. 8, Typical DC Current Gain vs. Collector Current (DRDN005W)

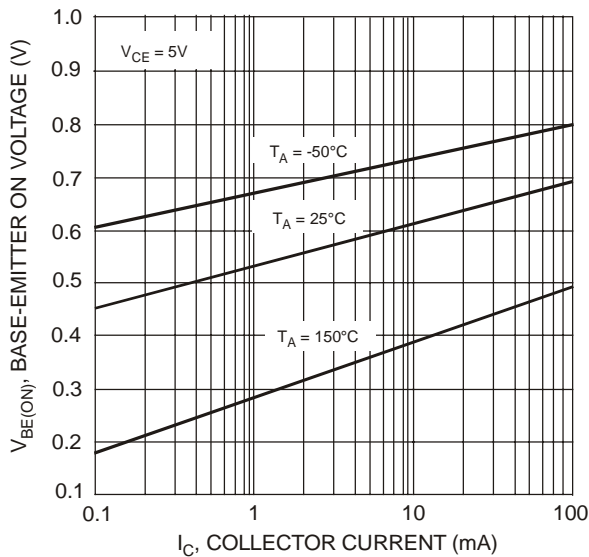

Fig. 9, Typical Base-Emitter On Voltage vs. Collector Current (DRDN005W)

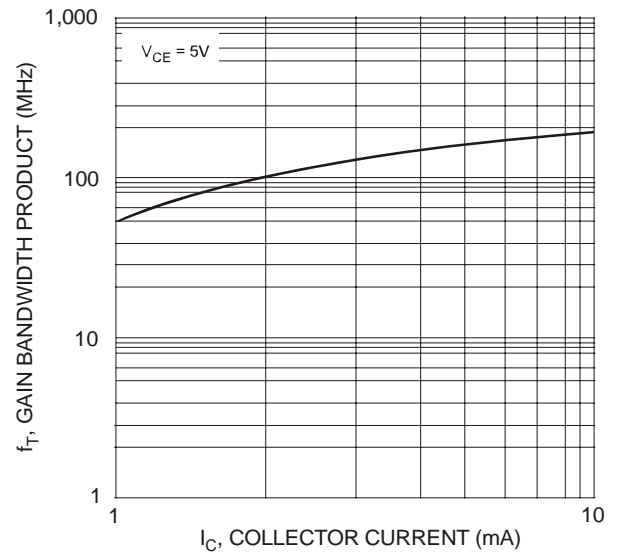

Fig. 10, Typical Gain Bandwidth Product vs. Collector Current (DRDN005W)

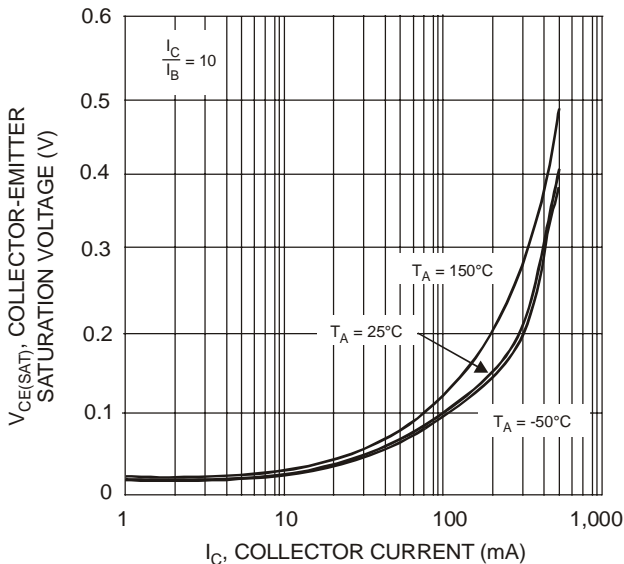

Fig. 11, Typical Collector-Emitter Saturation Voltage vs. Collector Current (DRDP006W)

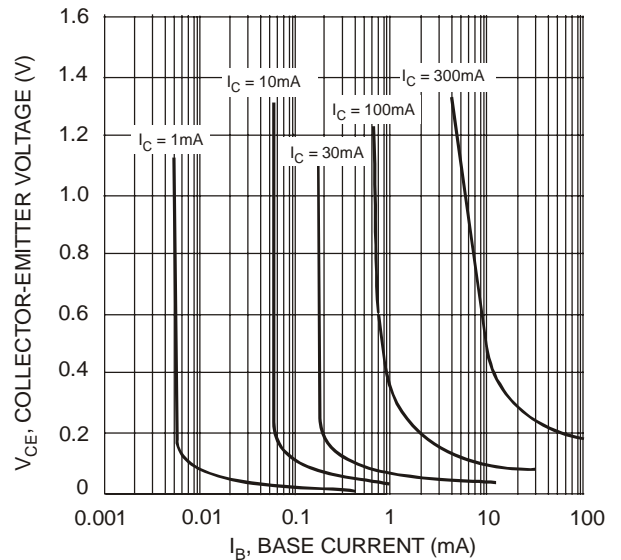

Fig. 12, Typical Collector Saturation Region (DRDP006W)

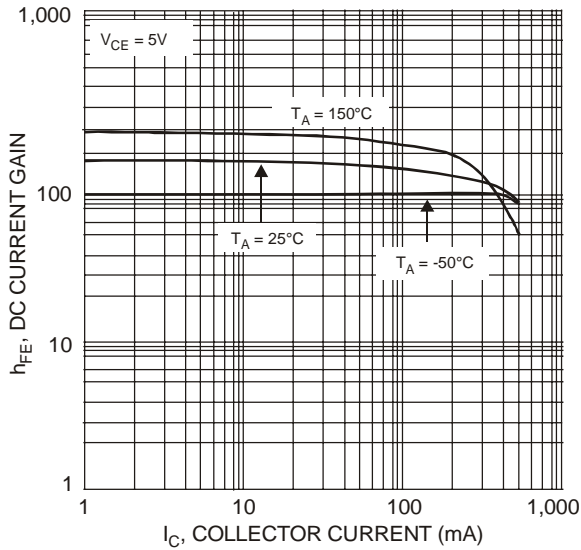

Fig. 13, Typical DC Current Gain vs. Collector Current (DRDP006W)

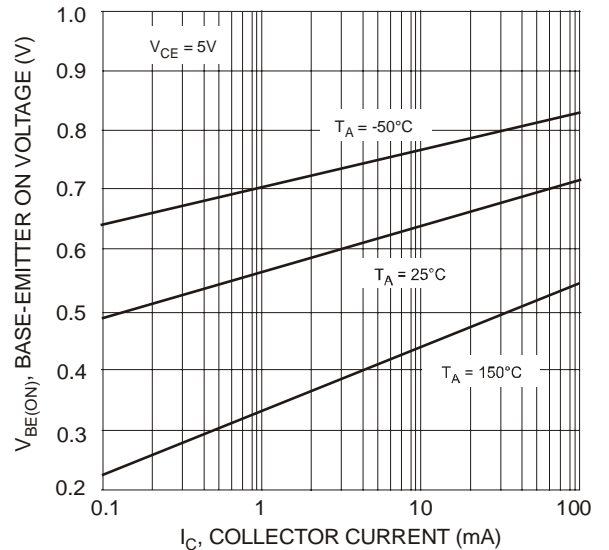

Fig. 14, Typical Base-Emitter On Voltage vs. Collector Current (DRDP006W)

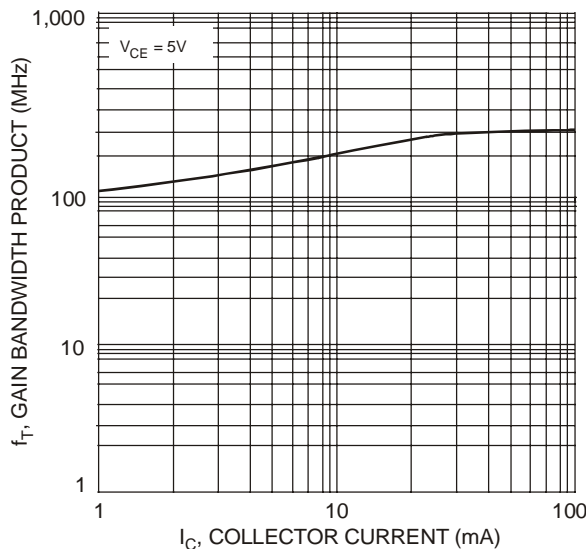

Fig. 15, Typical Gain Bandwidth Product vs. Collector Current (DRDP006W)

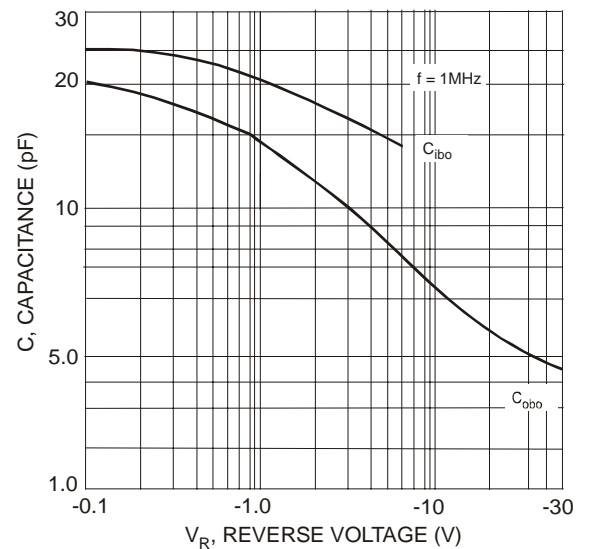

Fig. 16, Typical Capacitance (DRDP006W)

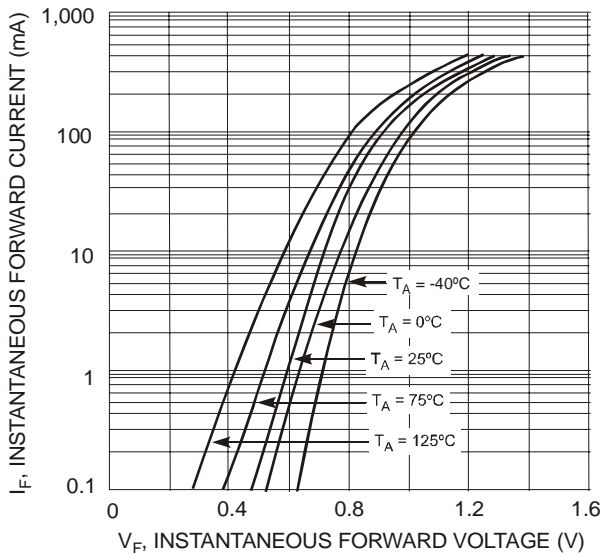

Fig. 17, Typical Forward Characteristics (Switching Diode)

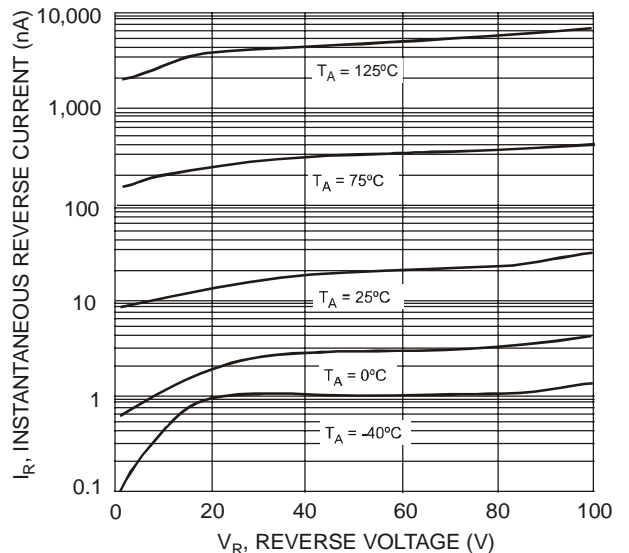

Fig. 18, Typical Reverse Characteristics (Switching Diode)

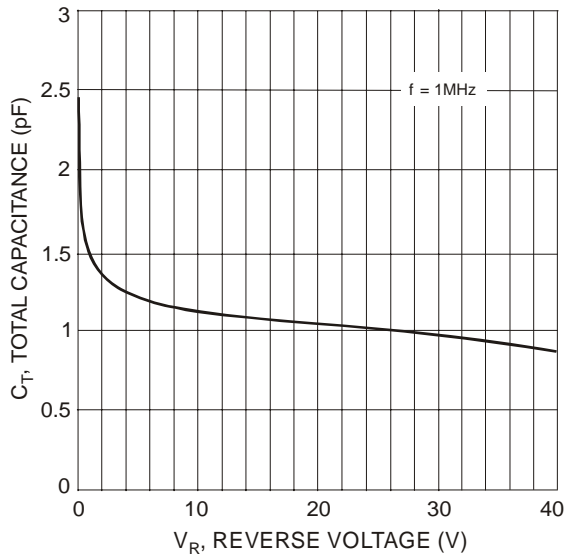

Fig. 19. Typical Capacitance vs. Reverse Voltage (Switching Diode)

Ordering Information (Note 5)

Device	Packaging	Shipping
DRDN010W-7	SOT-363	3000/Tape & Reel
DRDP006W-7	SOT-363	3000/Tape & Reel
DRDNB16W-7	SOT-363	3000/Tape & Reel
DRDNB26W-7	SOT-363	3000/Tape & Reel
DRDPB16W-7	SOT-363	3000/Tape & Reel
DRDPB26W-7	SOT-363	3000/Tape & Reel
DRDN005W-7	SOT-363	3000/Tape & Reel

Notes: 5. For packaging details, go to our website at <http://www.diodes.com/datasheets/ap02007.pdf>.

Marking Information

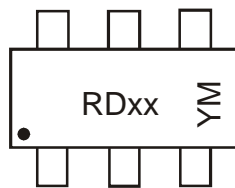

RDxx = Product Type Marking Code:

- RD01 = DRDN010W
- RD02 = DRDP006W
- RD03 = DRDNB16W
- RD04 = DRDNB26W
- RD05 = DRDPB16W
- RD06 = DRDPB26W
- RD07 = DRDN005W

YM = Date Code Marking

Y = Year ex: S = 2005

M = Month ex: 9 = September

Date Code Key

Year	2005	2006	2007	2008	2009	2010	2011	2012
Code	S	T	U	V	W	X	Y	Z

Month	Jan	Feb	Mar	Apr	May	Jun	Jul	Aug	Sep	Oct	Nov	Dec
Code	1	2	3	4	5	6	7	8	9	O	N	D

Sample Applications

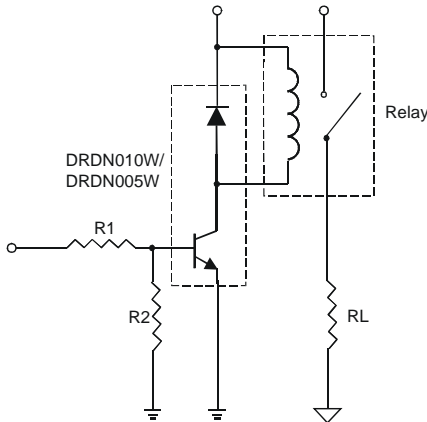

Application Example: DRDN010W/DRDN005W current sink configuration, bias resistors not included

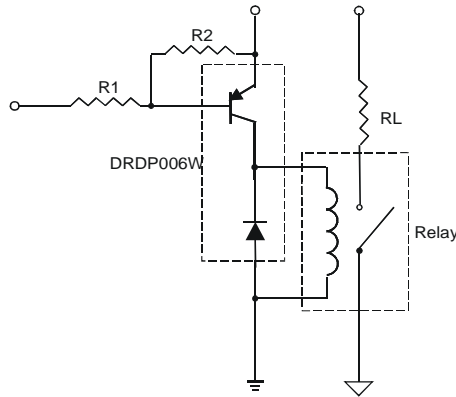

Application Example: DRDP006W current source configuration, bias resistors not included

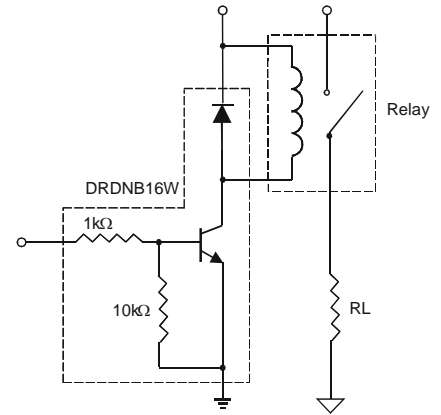

Application Example: DRDNB16W current sink configuration with built-in bias resistors

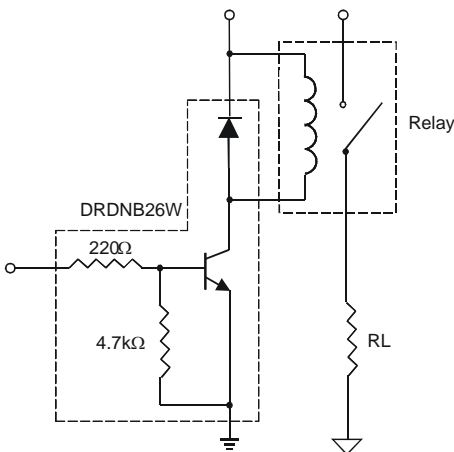

Application Example: DRDNB26W current sink configuration with built-in bias resistors (low R1)

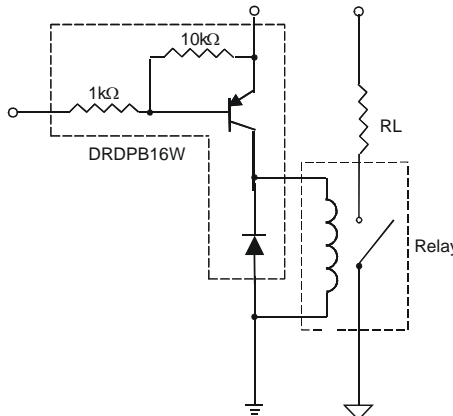

Application Example: DRDPB16W current source configuration with built-in bias resistors

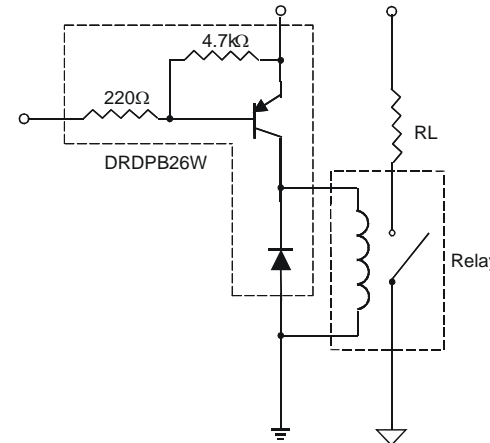

Application Example: DRDPB26W current source configuration with built-in bias resistors (low R1)

Suggested Pad Layout

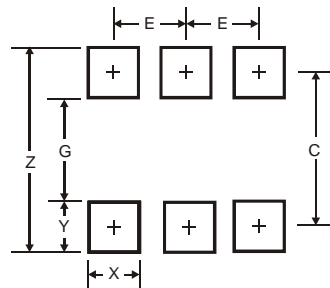

Dimensions	Value (in mm)
Z	2.5
G	1.3
X	0.42
Y	0.6
C	1.9
E	0.65

IMPORTANT NOTICE

Diodes Incorporated and its subsidiaries reserve the right to make modifications, enhancements, improvements, corrections or other changes without further notice to any product herein. Diodes Incorporated does not assume any liability arising out of the application or use of any product described herein; neither does it convey any license under its patent rights, nor the rights of others. The user of products in such applications shall assume all risks of such use and will agree to hold Diodes Incorporated and all the companies whose products are represented on our website, harmless against all damages.

LIFE SUPPORT

Diodes Incorporated products are not authorized for use as critical components in life support devices or systems without the expressed written approval of the President of Diodes Incorporated.