



Multiple Channel 1°C Temperature Sensor with Beta Compensation

PRODUCT FEATURES

Data Brief

General Description

The EMC1412 is a high accuracy, low cost, System Management Bus (SMBus) temperature sensor. Advanced features such as Resistance Error Correction (REC), Beta Compensation (to support CPU diodes requiring the BJT/transistor model including 45nm, 65nm and 90nm processors) and automatic diode type detection combine to provide a robust solution for complex environmental monitoring applications.

The EMC1412 monitors two temperature channels (one external and one internal). It provides $\pm 1^\circ\text{C}$ accuracy for both external and internal diode temperatures.

Resistance Error Correction automatically eliminates the temperature error caused by series resistance allowing greater flexibility in routing thermal diodes. Beta Compensation eliminates temperature errors caused by low, variable beta transistors common in today's fine geometry processors. The automatic beta detection feature monitors the external diode/transistor and determines the optimum sensor settings for accurate temperature measurements regardless of processor technology. This frees the user from providing unique sensor configurations for each temperature monitoring application. These advanced features plus $\pm 1^\circ\text{C}$ measurement accuracy provide a low-cost, highly flexible and accurate solution for critical temperature monitoring applications.

Applications

- Notebook Computers
- Desktop Computers
- Industrial
- Embedded applications

Features

- Programmable SMBus address
- Support for diodes requiring the BJT/transistor model
 - supports 45nm, 65nm, and 90nm CPU thermal diodes
- Automatically determines external diode type and optimal settings
- Resistance Error Correction
- External Temperature Monitor
 - $\pm 1^\circ\text{C}$ max accuracy ($20^\circ\text{C} < T_{\text{DIODE}} < 110^\circ\text{C}$)
 - 0.125°C resolution
 - Supports up to 2.2nF diode filter capacitor
- Internal Temperature Monitor
 - $\pm 1^\circ\text{C}$ accuracy
 - 0.125°C resolution
- 3.3V Supply Voltage
- Programmable temperature limits for ALERT and THERM
- Available in small 8-pin 2mm x 3mm TDFN lead-free RoHS compliant package
- Available in small 8-pin MSOP lead-free RoHS compliant package

Ordering Information:

ORDERING NUMBER	PACKAGE	FEATURES	SMBUS ADDRESS
EMC1412-A-ACZL-TR	8-pin MSOP (lead-free RoHS compliant)	Two temperature sensors, ALERT and THERM pins, programmable SMBus address	Selectable via THERM pull-up
EMC1412-A-AC3-TR	8-pin TDFN 2mm x 3mm (lead-free RoHS compliant)	Two temperature sensors, ALERT and THERM pins, fixed SMBus address	Selectable via THERM pull-up
EMC1412-1-ACZL-TR	8-pin MSOP (lead-free RoHS compliant)	Two temperature sensors, ALERT and THERM pins, fixed SMBus address	1001_100(r/w)
EMC1412-1-AC3-TR	8-pin TDFN 2mm x 3mm (lead-free RoHS compliant)	Two temperature sensors, ALERT and THERM pins, fixed SMBus address	1001_100(r/w)
EMC1412-2-ACZL-TR	8-pin MSOP (lead-free RoHS compliant)	Two temperature sensors, ALERT and THERM pins, fixed SMBus address	1001_101(r/w)

REEL SIZE IS 4,000 PIECES FOR THE MSOP

REEL SIZE IS 5,000 PIECES FOR THE TDFN

This product meets the halogen maximum concentration values per IEC61249-2-21

For RoHS compliance and environmental information, please visit www.smSC.com/rohs



80 ARKAY DRIVE, HAUPPAUGE, NY 11788 (631) 435-6000 or 1 (800) 443-SEMI

Copyright © 2012 SMSC or its subsidiaries. All rights reserved.

Circuit diagrams and other information relating to SMSC products are included as a means of illustrating typical applications. Consequently, complete information sufficient for construction purposes is not necessarily given. Although the information has been checked and is believed to be accurate, no responsibility is assumed for inaccuracies. SMSC reserves the right to make changes to specifications and product descriptions at any time without notice. Contact your local SMSC sales office to obtain the latest specifications before placing your product order. The provision of this information does not convey to the purchaser of the described semiconductor devices any licenses under any patent rights or other intellectual property rights of SMSC or others. All sales are expressly conditional on your agreement to the terms and conditions of the most recently dated version of SMSC's standard Terms of Sale Agreement dated before the date of your order (the "Terms of Sale Agreement"). The product may contain design defects or errors known as anomalies which may cause the product's functions to deviate from published specifications. Anomaly sheets are available upon request. SMSC products are not designed, intended, authorized or warranted for use in any life support or other application where product failure could cause or contribute to personal injury or severe property damage. Any and all such uses without prior written approval of an Officer of SMSC and further testing and/or modification will be fully at the risk of the customer. Copies of this document or other SMSC literature, as well as the Terms of Sale Agreement, may be obtained by visiting SMSC's website at <http://www.smSC.com>. SMSC is a registered trademark of Standard Microsystems Corporation ("SMSC"). Product names and company names are the trademarks of their respective holders.

SMSC DISCLAIMS AND EXCLUDES ANY AND ALL WARRANTIES, INCLUDING WITHOUT LIMITATION ANY AND ALL IMPLIED WARRANTIES OF MERCHANTABILITY, FITNESS FOR A PARTICULAR PURPOSE, TITLE, AND AGAINST INFRINGEMENT AND THE LIKE, AND ANY AND ALL WARRANTIES ARISING FROM ANY COURSE OF DEALING OR USAGE OF TRADE. IN NO EVENT SHALL SMSC BE LIABLE FOR ANY DIRECT, INCIDENTAL, INDIRECT, SPECIAL, PUNITIVE, OR CONSEQUENTIAL DAMAGES; OR FOR LOST DATA, PROFITS, SAVINGS OR REVENUES OF ANY KIND; REGARDLESS OF THE FORM OF ACTION, WHETHER BASED ON CONTRACT; TORT; NEGLIGENCE OF SMSC OR OTHERS; STRICT LIABILITY; BREACH OF WARRANTY; OR OTHERWISE; WHETHER OR NOT ANY REMEDY OF BUYER IS HELD TO HAVE FAILED OF ITS ESSENTIAL PURPOSE, AND WHETHER OR NOT SMSC HAS BEEN ADVISED OF THE POSSIBILITY OF SUCH DAMAGES.

Block Diagram

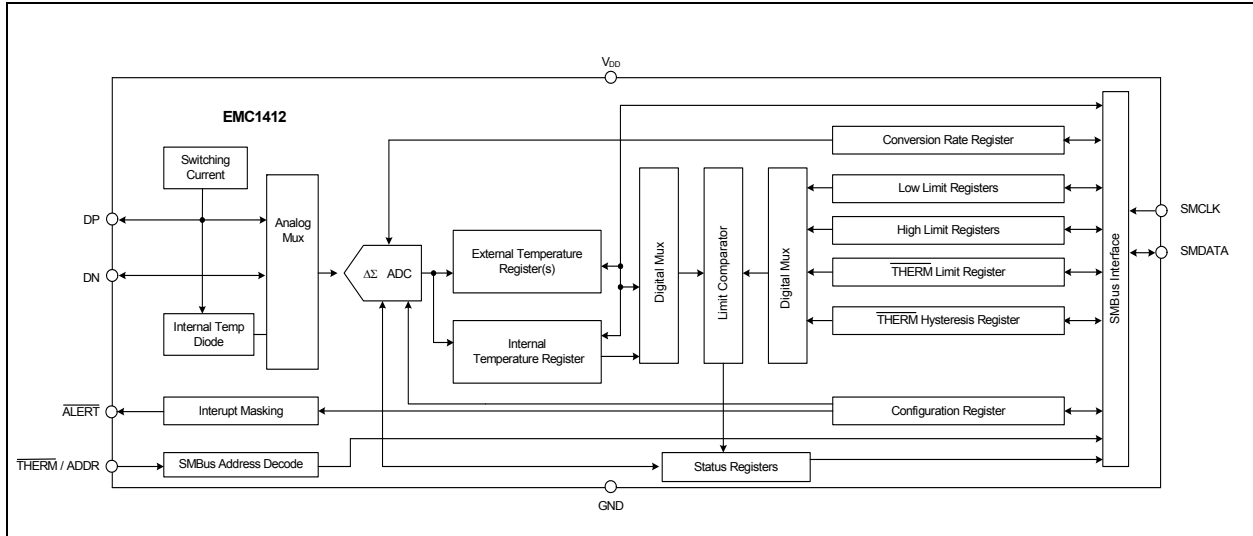

Figure 1 EMC1412 Block Diagram

Package Outlines

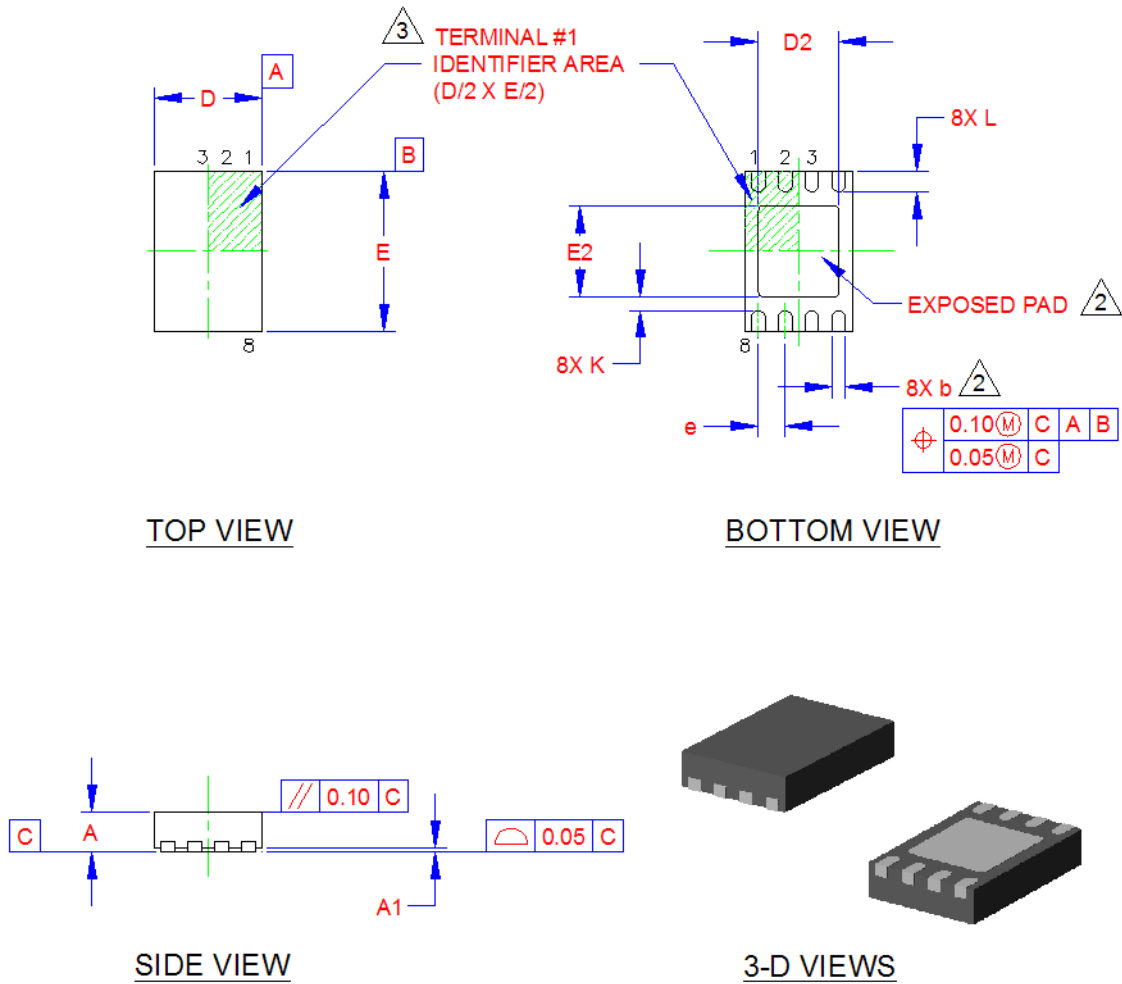

Figure 2 EMC1412 2mm x 3mm TDFN Package Drawing

COMMON DIMENSIONS					
SYMBOL	MIN	NOM	MAX	NOTE	REMARK
A	0.70	0.75	0.80	-	OVERALL PACKAGE HEIGHT
A1	0	0.02	0.05	-	STANDOFF
D	1.90	2.00	2.10	-	X BODY SIZE
E	2.90	3.00	3.10	-	Y BODY SIZE
D2	1.40	1.50	1.60	2	X EXPOSED PAD SIZE
E2	1.60	1.70	1.80	2	Y EXPOSED PAD SIZE
L	0.35	0.40	0.45	-	TERMINAL LENGTH
b	0.18	0.25	0.30	2	TERMINAL WIDTH
K	0.20	0.25	-	-	CENTER PAD TO PIN CLEARANCE
e	0.50 BSC		-	-	TERMINAL PITCH

NOTES:

1. ALL DIMENSIONS ARE IN MILLIMETERS.
2. UNILATERAL COPLANARITY ZONE APPLIES TO THE EXPOSED PAD, AS WELL AS THE TERMINALS. DIMENSIONS "b" APPLIES TO PLATED TERMINALS AND IT IS MEASURED BETWEEN 0.15 AND 0.30 mm FROM THE TERMINAL TIP.
3. DETAILS OF TERMINAL #1 IDENTIFIER ARE OPTIONAL BUT MUST BE LOCATED WITHIN THE AREA INDICATED.

Figure 3 EMC1412 2mm x 3mm TDFN Package Dimensions

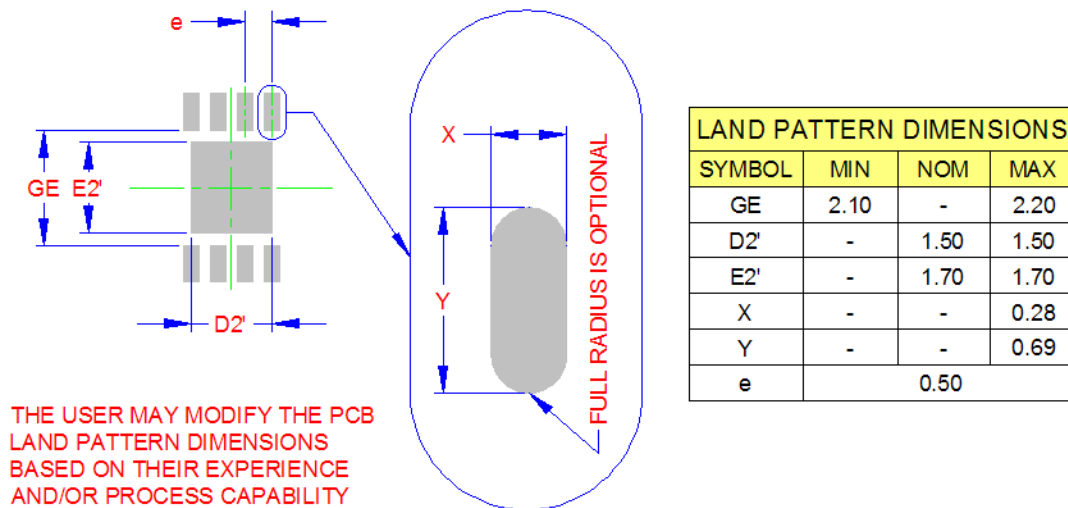

RECOMMENDED PCB LAND PATTERN

Figure 4 EMC1412 2mm x 3mm TDFN Package PCB Land Pattern

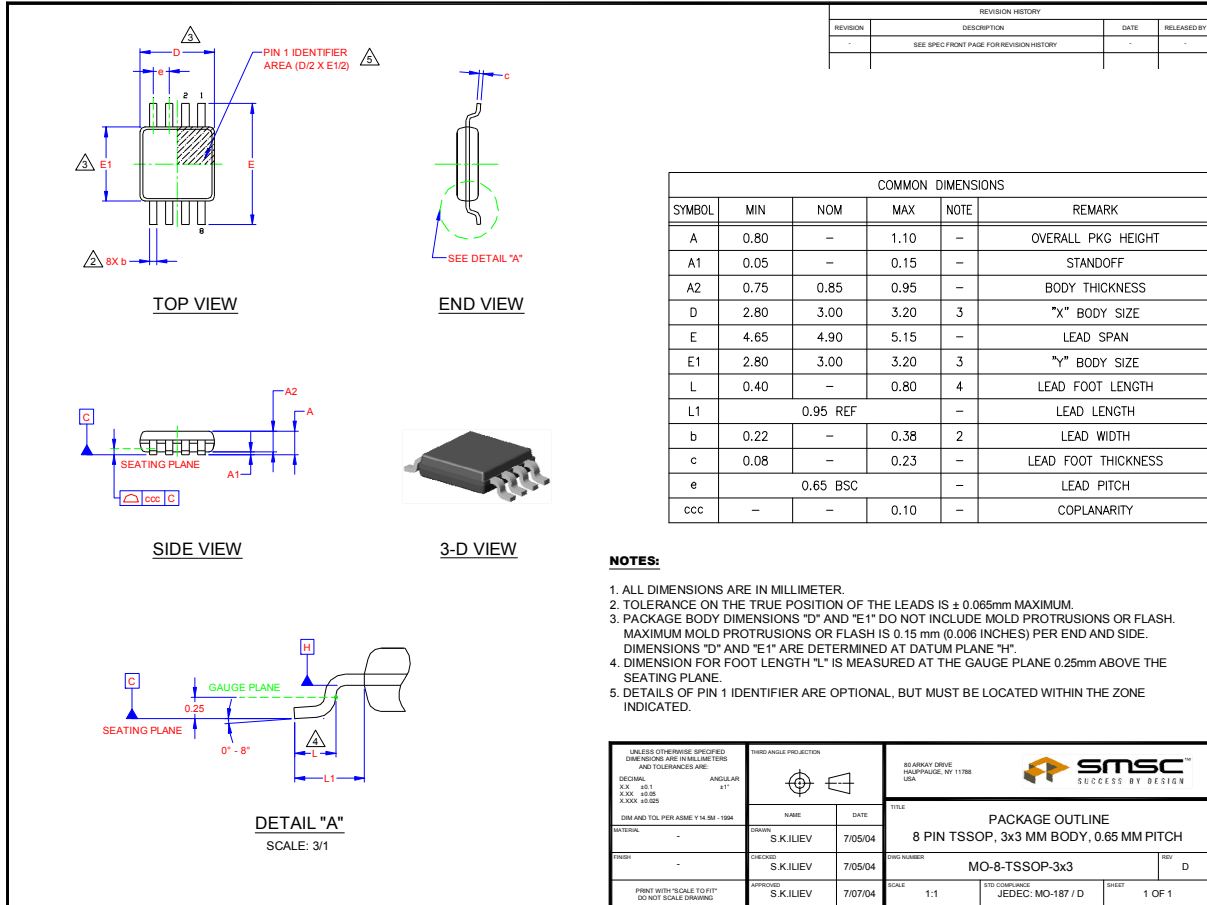

Figure 5 8-Pin MSOP / TSSOP Package

Mouser Electronics

Authorized Distributor

Click to View Pricing, Inventory, Delivery & Lifecycle Information:

[Microchip:](#)

[EMC1412-1-AC3-TR](#) [EMC1412-A-ACZL-TR](#)