

TO-220

Wärmewiderstand
Thermal resistance: 40 K/W

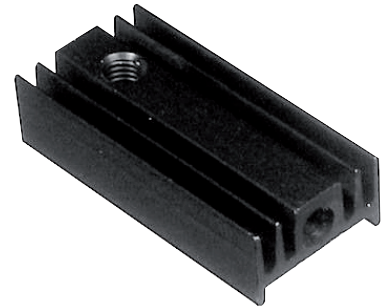
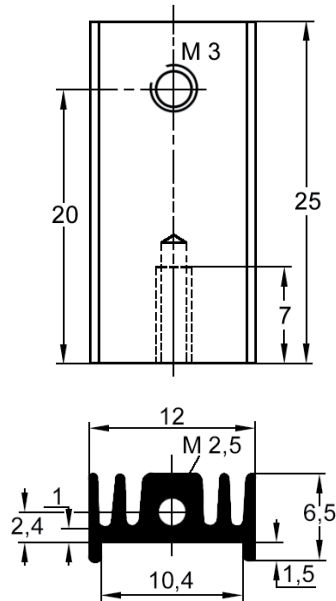

Bestellcode
Ordercode

V 5629 G

KLP

KLM

TO-220

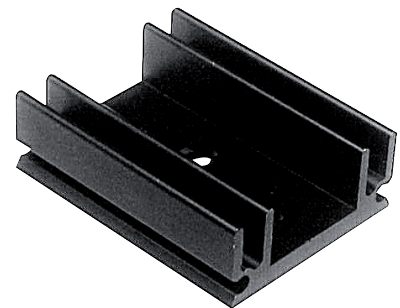
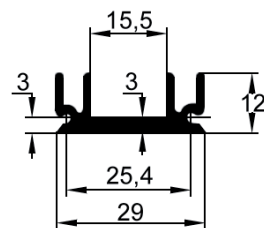
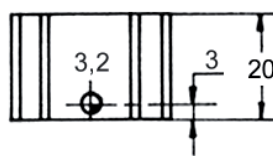
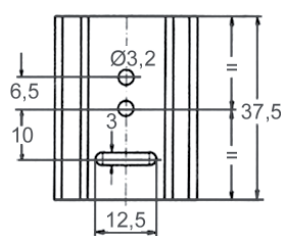
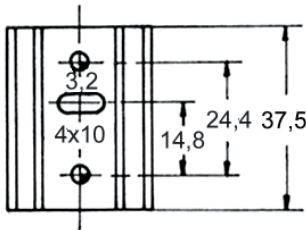

Option Option	Lochbild Hole pattern	Wärmewiderstand Thermal Resistance (K/W)
N	TO-220	15
K	KLP	13
R	KLM	13

Ausführung mit Lötstift: Seite 460
Version with solder pin: Page 460

Bestellcode
Ordercode

V 6560 x

Bitte „x“ durch die geeignete Option ersetzen
Please replace „x“ with appropriate option

Alle Typen werden in schwarz eloxierter Ausführung geliefert
All types will be delivered in black anodized finish

- Finger- und U-Kühlkörper
- Aufsteckkühlkörper
- Kühlkörper mit Lötstiften
- Kühlkörper Standardlänge
- CPU Kühlkörper
- Profile
- Halteklammern
- Montagezubehör
- Abstandhalter
- Lüfter
- Technische Erläuterungen