

Evaluating the **ADP1071-2** Isolated Synchronous Flyback Controller with Integrated *iCoupler*

FEATURES

- Full support evaluation kit for the **ADP1071-2**
- 36 W flyback topology
- 12.1 V output voltage (Vdc)
- 3 A steady state, 5 A peak
- Forced CCM operation
- Dedicated internal primary and secondary side MOSFET drivers
- External reference signal tracking
- Precision enabled undervoltage lockout with hysteresis
- Short-circuit, output overvoltage, cycle by cycle input overcurrent, and over temperature protection
- Frequency synchronization
- Soft start and soft stop functionality

EVALUATION KIT CONTENTS

ADP1071-2EBZ12.1V

ADDITIONAL EQUIPMENT NEEDED

- DC power supply capable of 36 Vdc to 60 Vdc, 3 A
- Electronic load capable of 150 W, 0 V to 60 V
- Oscilloscope capable of ≥ 500 MHz bandwidth, 2 channels to 4 channels
- Precision digital multimeter (HP34401 or equivalent)

GENERAL DESCRIPTION

The ADP1071-2EBZ12.1V evaluation board allows users to evaluate the **ADP1071-2** in a power supply application.

The evaluation board is set up to act as an isolated power supply unit (PSU), with a rated load of 12.1 Vdc, 3 A in steady state (5 A peak) from a 36 Vdc to 60 Vdc source.

Connectors on the ADP1071-2EBZ12.1V provide synchronization, allowing direct paralleling evaluation when multiple ADP1071-2EBZ12.1V evaluation boards are connected in parallel to a common bus.

Multiple test points allow easy access to all critical nodes and pins.

Complete information about the **ADP1071-2** is available in the **ADP1071-1/ADP1071-2** data sheet, which should be consulted in conjunction with this user guide when using the evaluation board.

ADP1071-2EBZ12.1V EVALUATION BOARD SETUP

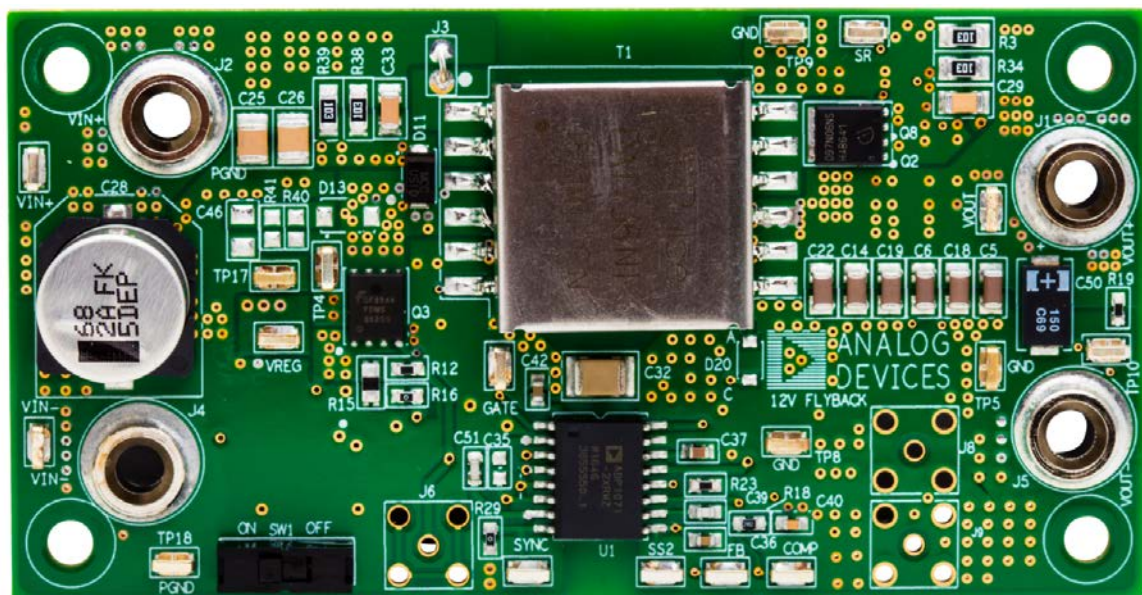

Figure 1.

15757-001

TABLE OF CONTENTS

Features	1	Evaluating the ADP1071-2.....	5
Evaluation Kit Contents.....	1	Gate and SR Pins and Functionality	5
Additional Equipment Needed.....	1	Soft Start	6
General Description	1	Soft Stop.....	6
ADP1071-2EBZ12.1V Evaluation Board Setup	1	Output Ripple	6
Revision History	2	Control Loop.....	7
Evaluation Board Overview	3	External Signal Tracking	7
Power Train Overview	3	Over Current Protection (OCP)	8
Applications.....	3	Voltage and Current Stress.....	8
Connectors	3	Efficiency Curves	9
Caution	3	Thermal Performance.....	9
Evaluation Board Hardware.....	4	Evaluation Board Schematic and Artwork.....	10
Evaluation Board Configurations	4	Ordering Information.....	14
Powering Up.....	4	Bill of Materials.....	14
ADP1071-2EBZ12.1V Dimensions.....	4		

REVISION HISTORY

12/2018—Rev. 0 to Rev A.
 Change to Figure 21 10

10/2018—Revision 0: Initial Version

EVALUATION BOARD OVERVIEW

This evaluation board features the [ADP1071-2](#) in a dc-to-dc switching power supply in flyback topology with synchronous rectification operating at 300 kHz switching frequency.

The [ADP1071-2](#) circuit is designed to provide a rated load of 12.1 Vdc, 3 A from a dc input voltage source of 36 Vdc to 60 Vdc. The [ADP1071-2](#) operates in continuous conduction mode (CCM) and provides features including precision undervoltage lockout (UVLO), output voltage regulation, synchronization, constant current control, prebias start up, and comprehensive protection functions.

POWER TRAIN OVERVIEW

The evaluation board is shown in Figure 1. The circuit components on the ADP1071-2EBZ12.1V are described as follows:

- The input filter consists of a capacitor bank including C24 to C28.
- Q3 is an N-channel metal-oxide semiconductor field effect transistor (MOSFET), used as the main switch on the primary side.
- Transformer T1 provides isolation.
- The secondary side of the evaluation board has an N-channel MOSFET (Q2) as the synchronous rectifier (SR).
- The output filter consists of a capacitor bank including C5, C6, C14, C18, C19, and C50. This is the main power stage.

Additional circuitry around the power train is described as follows. The resistor capacitor diode (RCD) snubber for main switch comprises R38, R39, C33, and D11. The RCD snubber for SR comprises R3, R34, C29, and D19.

The [ADP1071-2](#) (U1) is the power controller. It integrates gate drive for driving the primary switch and synchronous rectifier based on the Analog Devices, Inc., *iCoupler*® technology.

During start up, U1 is powered by the J2 or J4 input via an external start-up circuit (Q7, R17, D5, and C38). Once switching starts, the T1 transformer has an auxiliary winding that provides power to the VREG1 pin. R15 senses the primary current.

APPLICATIONS

High efficiency, high power density, isolated dc-to-dc power supplies include the following:

- Intermediate bus converters
- Paralleled power supply systems
- Power over Ethernet (PoE)
- Server, storage, industrial, networking, and infrastructure, for example

CONNECTORS

The connections to the ADP1071-2EBZ12.1V evaluation board are shown in Table 1.

Table 1. Evaluation Board Connections

Connector	Function
J2	VIN+, dc input
J4	VIN-, ground return for dc input
J1	VOUT+, dc output
J5	VOUT-, return for dc output

CAUTION

This evaluation board uses high voltages. Take extreme caution, especially on the primary side, to ensure safety. It is advised to switch off the evaluation board when not in use. Use a current limited, isolated dc source at the input.

EVALUATION BOARD HARDWARE

EVALUATION BOARD CONFIGURATIONS

The evaluation board comes preconfigured with the default settings to operate the power supply at the rated load. No additional configuration is necessary other than to turn on the hardware on switch (SW1). Replace J3 with a wire to monitor the primary current.

POWERING UP

1. Connect a dc source (voltage range of 36 Vdc to 60 Vdc) at the input terminals and an electronic load at the output terminals.
2. Connect voltmeters on the input terminals (VIN+ and VIN-) and output terminals (VOUT and GND) separately.
3. Connect the voltage probes at different test pins. Use the differential probes and ensure the ground of the probes are isolated if the measurements are made on the primary and secondary side of the transformer (T1) simultaneously.
4. Set the electronic load to 3 A.
5. Turn SW1 to the on position.

The output must read 12.1 Vdc.

ADP1071-2EBZ12.1V DIMENSIONS

Table 2 shows the dimensions of the ADP1071-2EBZ12.1V evaluation board. The dimensions exclude standoff.

Table 2. Evaluation Board Dimensions

Dimension	Value (Inches)
Length	2.0
Width	3.8
Height	0.625 (excluding standoffs)

EVALUATING THE ADP1071-2

Several test points on the evaluation board allow easy monitoring of the various signals. The user can program the operation of the evaluation board according to the [ADP1071-1/ADP1071-2](#) data sheet. The following sections provide descriptions of the typical features and results when evaluating the device.

GATE AND SR PINS AND FUNCTIONALITY

The gate signals, GATE and SR, are generated by isolated gate drivers within [ADP1071-2](#). There is only one logic low level which is zero. The maximum voltage on GATE is the VREG1 pin voltage and the maximum voltage of the SR pin is the VREG2 pin voltage. An example of GATE and SR waveforms is shown in Figure 2. All the signals shown represent the signals at the output pins of the integrated circuit (IC).

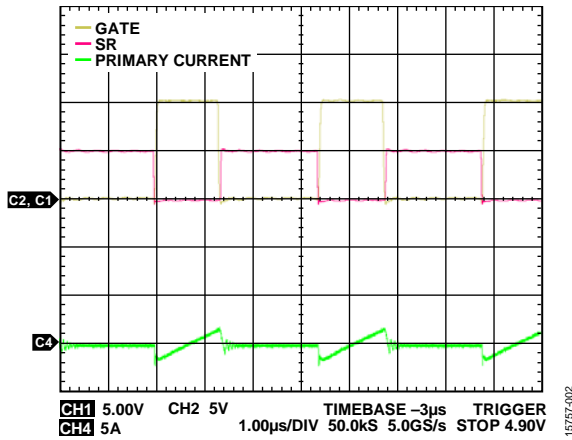

Figure 2. GATE and SR Example at 48 Vdc Input and No Load

Dead Time

The dead time between the GATE and SR signals is measured at 48 Vdc input and no load. All the signals shown represent the signals at the output pins of the IC.

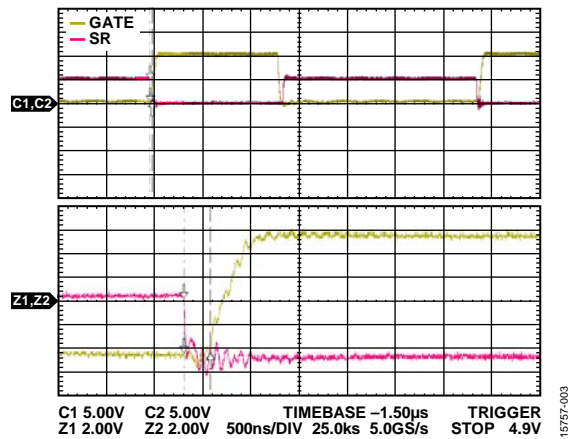

Figure 3. Dead Time Example at 48 Vdc Input and No Load, Measured Dead Time is 28 ns

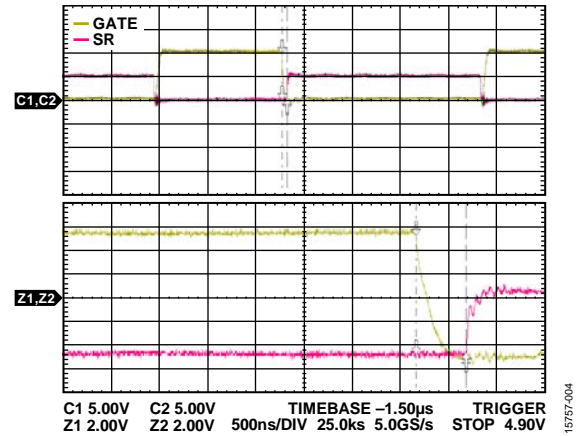

Figure 4. Deadtime Example at 48 Vdc Input and No Load, Measured Dead Time is 52 ns

Frequency Synchronization

The internal oscillator frequency can be programmed by setting the R27 resistor. The evaluation board comes with a 120 kΩ resistor, corresponding to a 200 kHz switching frequency. The oscillator can also synchronize to an external signal. To do this, remove the R29 resistor and connect a function generator output to the SYNC test point. The loop can become unstable if the external frequency is set too high. Refer to the [ADP1071-1/ADP1071-2](#) data sheet for details.

PMW Jitter

Figure 5 shows the typical GATE PWM jitter at a nominal input voltage of 48 Vdc and a load of 3A.

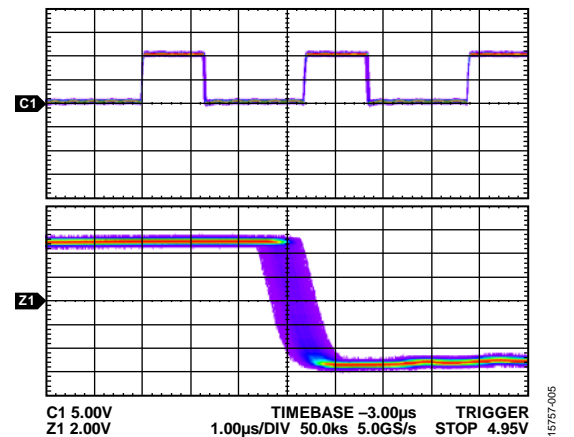

Figure 5. GATE PWM Jitter at 48 Vdc Input and 3A Load

SOFT START

Once the voltage at the EN pin exceeds the enable threshold, the converter enters a two-stage soft start sequence allowing the output voltage to ramp up smoothly. For details, refer to the [ADP1071-1/ADP1071-2](#) data sheet. Figure 6 shows the soft start under a no load condition.

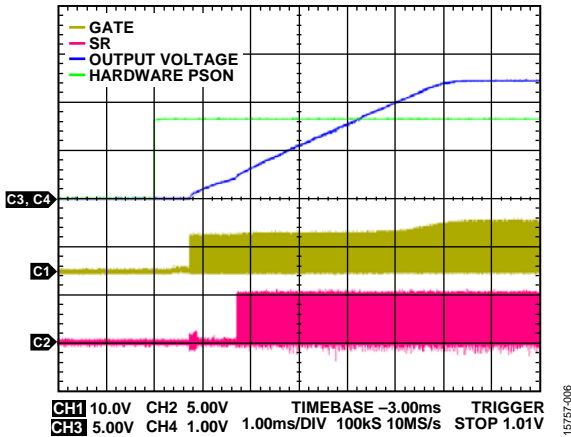

Figure 6. Soft Start at 48 Vdc Input, 0 A

When soft starting into a precharged output, the SR gate is prevented from turning on until the COMP voltage reaches the precharged feedback voltage. This soft start scheme prevents the output from discharging and prevents reverse current through the SR MOSFETs during soft start.

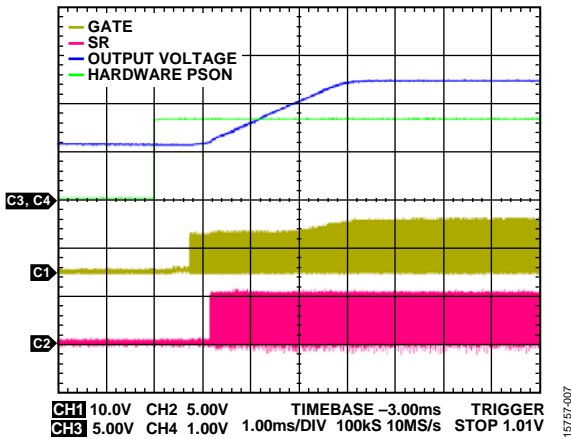

Figure 7. Soft Start from Precharge

To experiment with different soft start timings, change the value of R14 as specified in the [ADP1071-2](#) data sheet.

SOFT STOP

When the voltage at EN drops below the EN threshold, the secondary drivers shut off immediately while the primary GATE pulse width gradually decreases to the minimum pulse width when the output drops. This soft stop feature prevents any reverse current when the controller shuts down. Figure 8 shows the typical soft stop behavior.

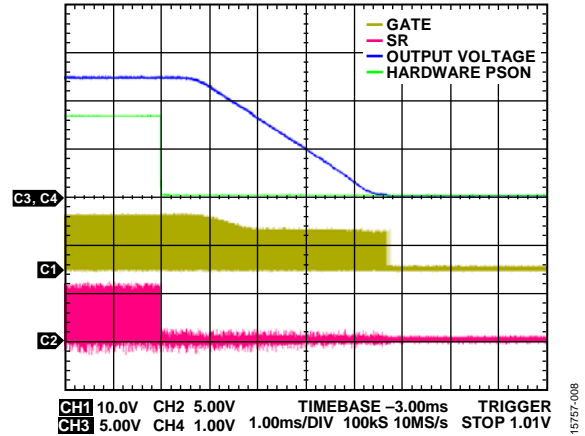

Figure 8. Soft Stop at 48 Vdc Input, 3 A Load

OUTPUT RIPPLE

Output ripple can be measured across the C50 capacitor. Minimize the loop area formed by the probe and its grounding to create clean waveforms.

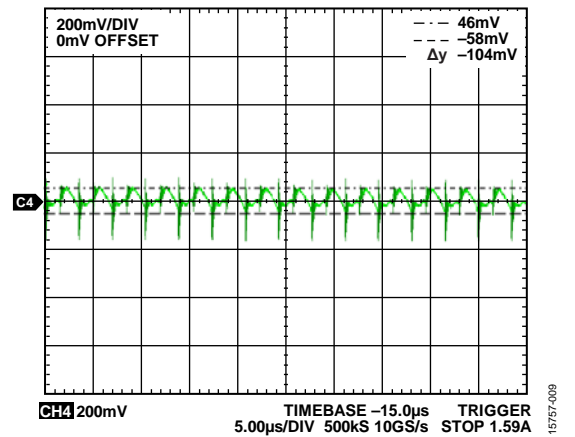

Figure 9. Output Ripple at 48 Vdc Input, No Load

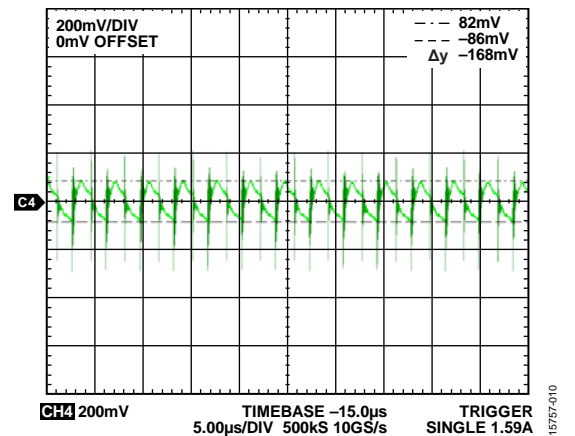

Figure 10. Output Ripple at 48 Vdc Input, 3 A Load

CONTROL LOOP

On the secondary side, the output voltage information is sensed a voltage divider and sent to the FB pin. The FB pin voltage is compared to a 1.2 V reference signal, and the error determines the COMP voltage. The COMP pin voltage information is sent to the primary side via *iCoupler* technology, allowing closed loop operation.

The loop gain can be measured via a network analyzer. The small signal perturbation is injected at R19 and VOUT+ test points. Figure 11 shows the loop gain of the system.

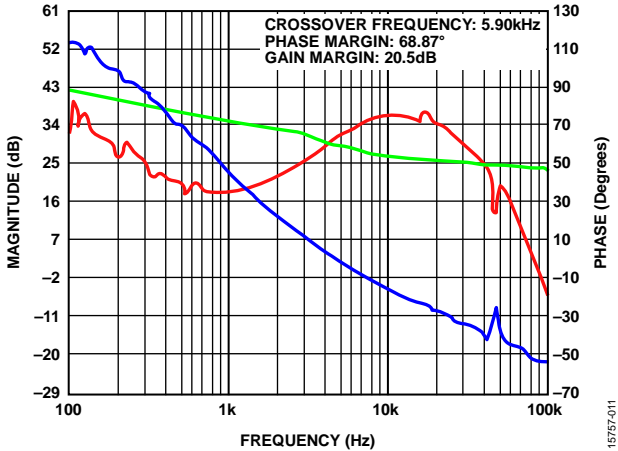

Figure 11. Loop Gain Measurement

Transient Response for Load Step

A dynamic electronic load can be connected to the output of the evaluation board to evaluate the transient response. Set up an oscilloscope to capture the transient waveform of the power supply output. Figure 12 shows an example of the load transient response. Change the R18 resistor and C39 and C40 capacitors connected at the COMP pin to change the transient response.

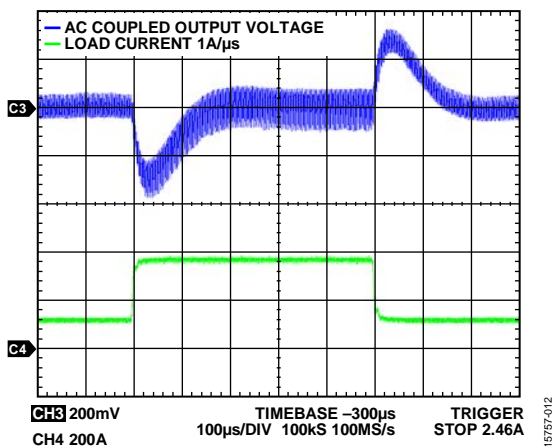

Figure 12. Transient Response with Load Steps: 25% to 75% to 25%

EXTERNAL SIGNAL TRACKING

The output voltage of the evaluation board can track an external signal applied to the SS2 pin. The applied peak value must be lower than 1.2 Vdc. Apply a 1 kHz, 200 mV peak-to-peak sinusoidal signal with 1.1 Vdc offset to SS2 in the example shown in Figure 13.

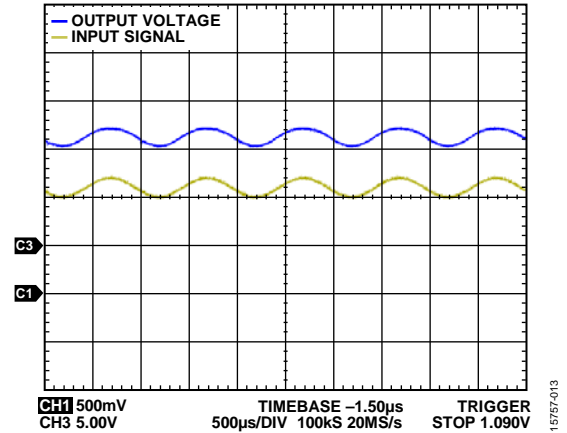

Figure 13. External Signal Tracking

OVER CURRENT PROTECTION (OCP)

The primary peak current is sensed by the cycle by cycle current sensing resistor, R15. When the sensed input peak current is above the CS pin limit threshold, the controller operates in the cycle by cycle constant current limit mode for 1.25 ms. The controller immediately shuts down the primary drivers and discharges the SS2 pin. The controller then goes into shutdown mode for the next 40 ms and restarts the soft start sequence. Figure 14 and Figure 15 show these protections features.

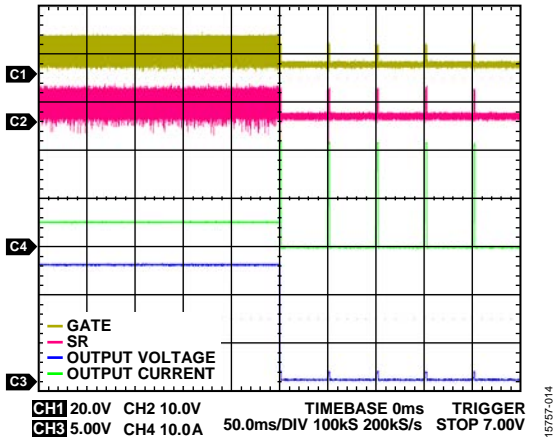

Figure 14. OCP Under Output Short Circuit at 48 Vdc

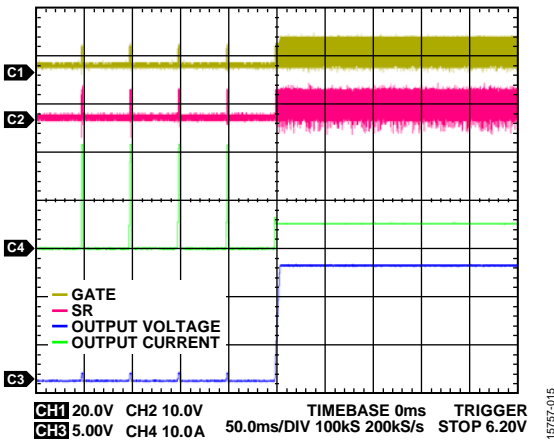

Figure 15. Recovery from Output Short Circuit at 48 Vdc

VOLTAGE AND CURRENT STRESS

The drain to source voltage of both the main switch and SR MOSFET are clamped by the RCD snubber on the evaluation board. The peak drain to source voltage occurs at the maximum input voltage and full load. Figure 16 shows the peak drain to source voltages of the main switch and synchronous rectifier are 143.4 V and 45.3 V, respectively.

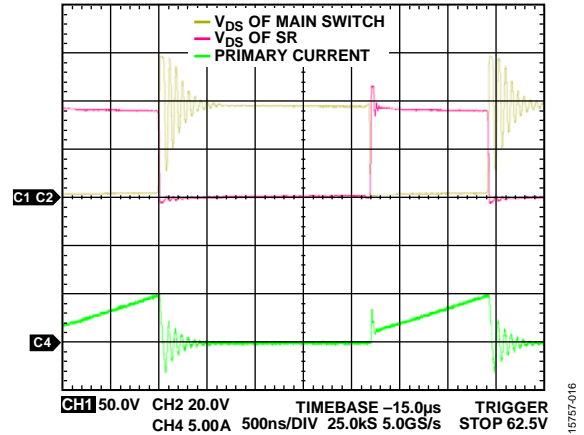

Figure 16. MOSFET Drain to Source Voltages at 60 Vdc Input and 5 A Load (V_{ds} means voltage from the drain source)

Peak current stress occurs at the minimum input voltage and full load, that is, at the 36 Vdc input and 5 A load (see Figure 17). The peak current is 5.43 A for the primary side. The rms value of the primary current under t condition is approximately 2.67 A.

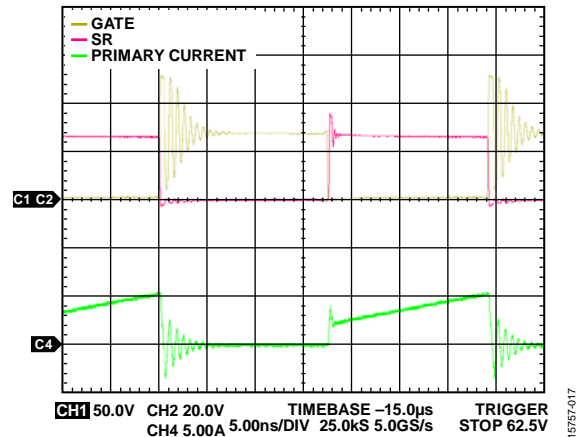

Figure 17. Peak Primary Current at 36 Vdc Input and 5 A Load

EFFICIENCY CURVES

Figure 18 and Figure 19 show the typical efficiency curves under line and load conditions, respectively.

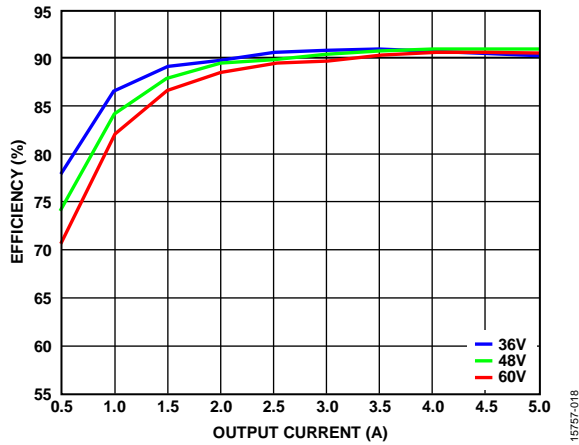

Figure 18. Efficiency Curves

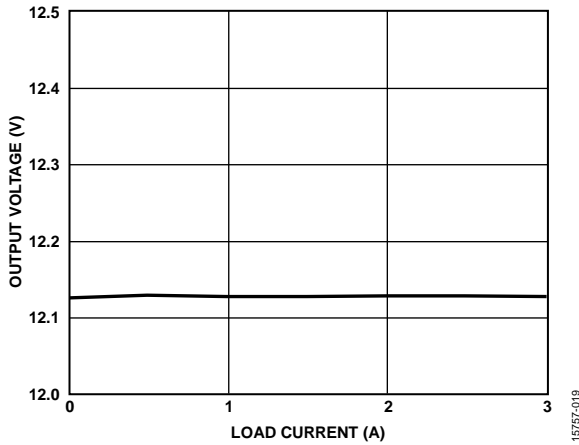

Figure 19. Load Regulation

THERMAL PERFORMANCE

Figure 20 show the typical thermal profile of the evaluation board at different operating conditions.

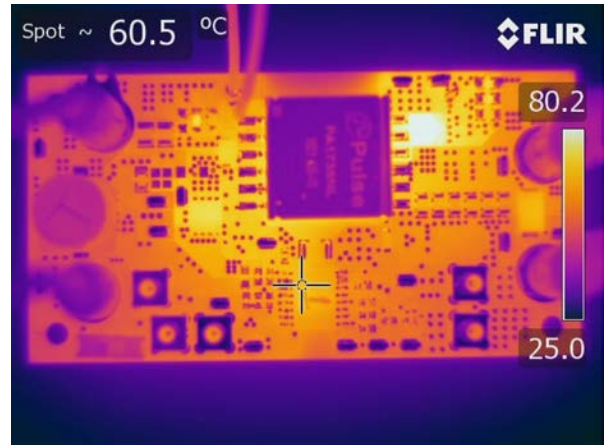

Figure 20. Thermal Image of the ADP1071-2 at 48 Vdc Input, 5 A Load, No Airflow, and 0.5 Hour Soaking Time

EVALUATION BOARD SCHEMATIC AND ARTWORK

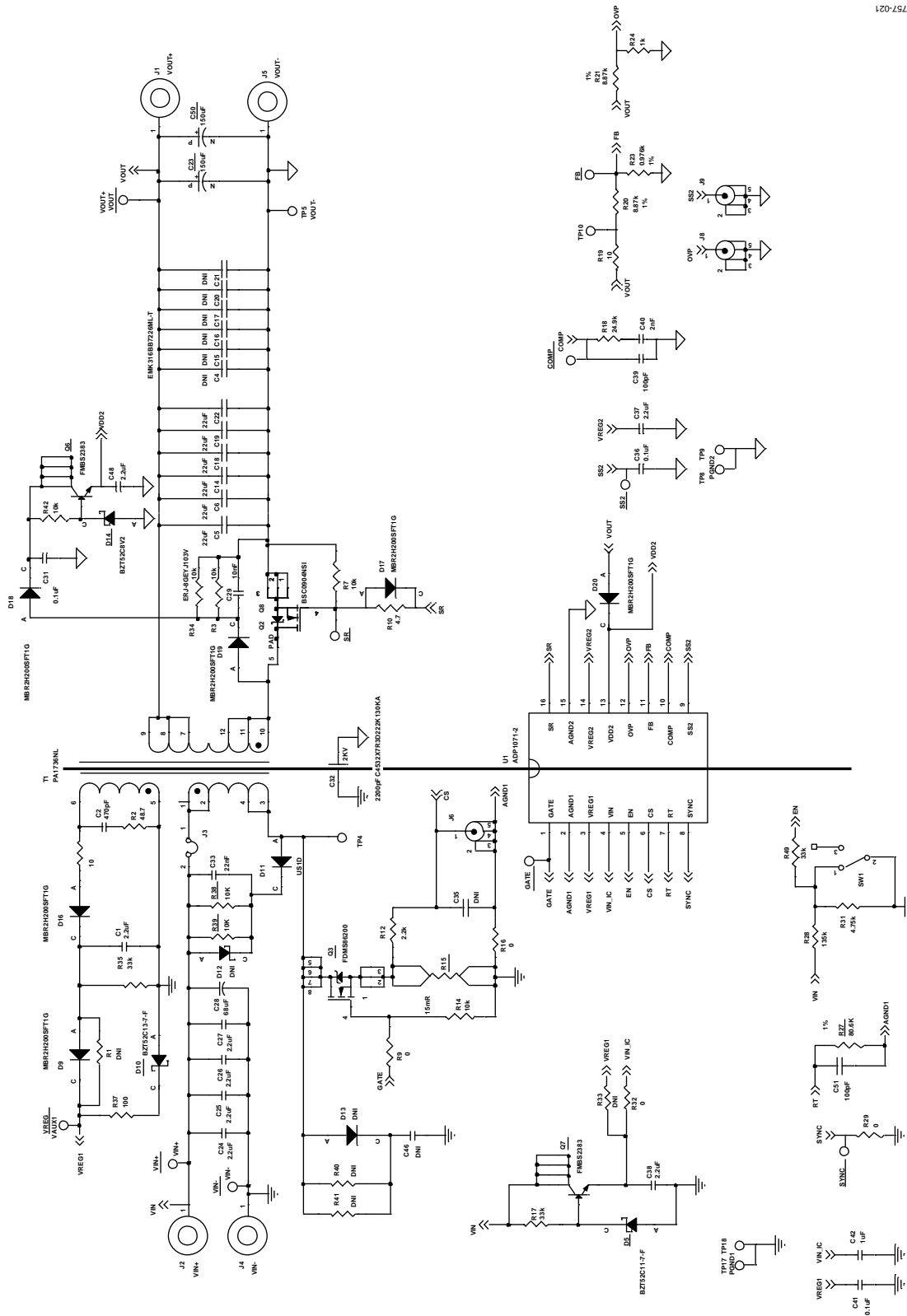
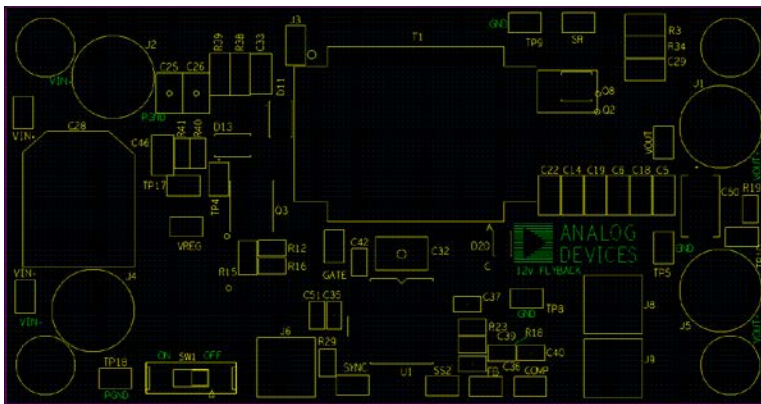

Figure 21. ADP1071-2EBZ12.1V Evaluation Board Schematic



15757-022

Figure 22. Board Outline



15757-023

Figure 23. Silkscreen Top

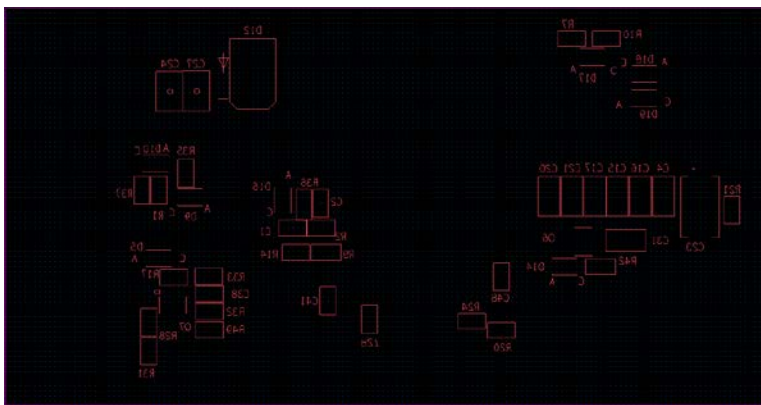

15757-024

Figure 24. Silkscreen Bottom

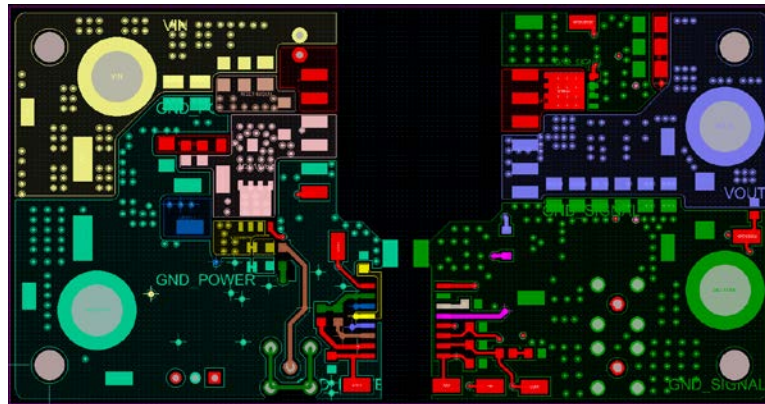

15757-025

Figure 25. PCB Layout, Top Layer

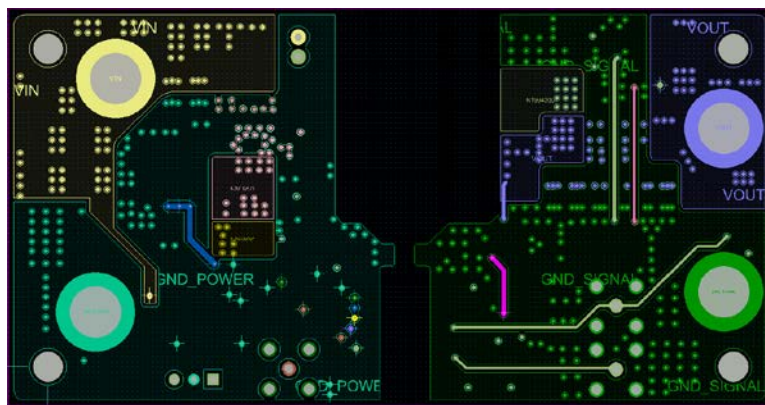

15757-026

Figure 26. PCB Layout, Layer 2



15757-027

Figure 27. PCB Layout, Layer 3

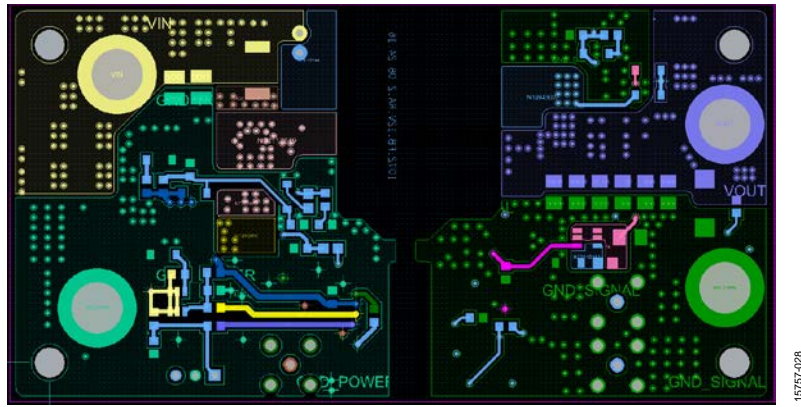

Figure 28. PCB Layout, Layer 4

15757-028

ORDERING INFORMATION

BILL OF MATERIALS

Table 3.

Reference Designator	Description	Manufacture	Part Number
C1, C37, C38, C48	Ceramic capacitors, 2.2 μ F, 50 V, 10%, X7R, surface mount device (SMD)	Murata	GRM188R61H225KE11D
C2	Ceramic capacitor, 470 pF, 100 V, 10%, X7R, SMD	Murata	GRM188R72A471KA01D
C5, C6, C14, C18, C19, C22	Ceramic capacitors, 47 μ F, 16 V, X5R	Taiyo Yuden	C3216X5R1C476M160AB
C4, C15 to C17, C21, C20	Do not install (DNI)		
C23, C50	Tantalum polymer capacitors, 150 μ F, 16 V	Panasonic	1CTQC15173F1
C24 to C27	Ceramic capacitors, 2.2 μ F, 100 V, 10%, X7R, SMD	AVX Corporation	12101C225KAT2A
C28	Aluminum capacitor, 100 V, 68 μ F, 20%	Panasonic	EEV-FK2A680Q
C29	Ceramic capacitors, 10 nF, 200 V, 10%, X7R, SMD	AVX	12062C103KAT2A
C31	Ceramic capacitor, 0.1 μ F, 200 V, X7R, 1206	Murata	C1206C104K2RACTU
C32	Ceramic capacitor, 2200 pF, 2 kV, X7R, 1812	TDK	C4532X7R3D222K130KA
C33	Ceramic capacitor, 0.022 μ F (22 nF), 250 V, X7R, 1206	TDK	C3216X7R2E223K115AA
C46	Ceramic capacitor, 0.022 μ F, 250 V, X7R, 1206, DNI	TDK	C3216X7R2E223K115AA
C35	Ceramic capacitor, 100 pF, 50 V, 10%, X7R, DNI, SMD	Kemet or equivalent	C0603C101K5RACTU
C39, C51	Ceramic capacitors, 100 pF, 50V, 10%, X7R SMD	Kemet or equivalent	C0603C101K5RACTU
C36, C41	Ceramic capacitors, 0.1 μ F, 25 V, 10%, X7R, SMD	AVX Corporation	06033C104KAT2A
C40	Ceramic capacitor, 2000 pF (2 nF), 100 V, 10%, X7R, SMD	AVX Corporation	06031C202KAT2A
C42, C43	Ceramic capacitors, 1 μ F, 50 V, X7R, 0603	T-Y	UMK107AB7105KA
D10, D5, D14	Zenner diodes, 11 V, 500 mW, 5%, BZT52C11-7-F	Diode Inc.	BZT52C11-7-F
D11	Ultrafast diode, 200 V, 1 A	MMC	US1D
D13	Ultrafast diode, 200 V, 1 A, DNI	MMC	US1D
D12	Transient voltage suppression Zenner diode, 40 V, DNI	Littlefuse	5.0SMDJ36
D9, D16 to D19	Ultrafast diodes, 200 V, 1A	ON Semiconductor	MBR2H200SFT1G
J1	Banana jack connector, VOUT+	Emerson	108-0740-001
J2	Banana jack connector, VIN+	Emerson	108-0740-001
J3	Jumper		
J4	Banana jack connector, VIN-	Emerson	108-0740-001
J5	Banana jack connector, VOUT-	Emerson	108-0740-001
J6, J8, J9	Jack connectors, vertical gold, DNI	Emerson	131-3701-261
Q2	N-channel power trench, 60 V, 46 A, 9.7 m Ω	Infineon	BSC097N06
Q3	N-channel power trench, 150 V, 35 A, 18 m Ω	Fairchild	FDMS86200
Q6, Q7	NPN transistors, 160 V, 0.8 A	Fairchild	FMBS2383
R1	SMD resistor, DNI, 1/8 W, jumper	Panasonic	ERJ-6GEY0R00V
R2	SMD resistor, 48.7 Ω , 1/8 W, 1%	Vishay/Dale	CRCW080548R7FKEA
R3, R34, R38, R39	SMD resistors, 10 k Ω , 0.25 W, 5%, 1206	Panasonic	ERJ-8GEYJ103V
R7, R14	SMD resistor, 10 k Ω , 1/8 W, 1%	Any	
R9	SMD resistor, 0 Ω , 1/8 W, jumper	Any	
R10	SMD resistor, 4.7 Ω , 1/8 W	Any	
R12	SMD resistor, 2.2 k Ω , 1/8 W, 1%	Any	
R15	Current sense resistor 15 m Ω , 1 W, 1%	Panasonic	ERJ-8BWFR015V
R16, R29, R32	SMD resistors, 0 Ω , 1/8 W, jumper	Any	
R17, R35, R49	SMD resistors, 33 k Ω , 1/8 W, 1%	Any	
R18	SMD resistor, 24.9 k Ω , 1/8 W 1%	Any	
R19	SMD resistor, 10 Ω , 1/10 W	Any	
R20, R21	SMD resistors, 8.87 k Ω , 1/8 W, 1%	Any	
R33	SMD resistor, DNI, 1/8 W, jumper	Any	
R23, R24	SMD resistors, 0.976 k Ω , 1/8 W, 1%	Any	

Reference Designator	Description	Manufacture	Part Number
R27	SMD resistor, 80.6 k Ω , 1/8 W, 1%	Any	
R28	SMD resistor, 133 k Ω , 1/5 W, 0.1%	Any	
R31	SMD resistor, 4.75 k Ω , 1/8 W, 1%	Any	
R36, R37	SMD resistors, 100 Ω , 1/8 W, 1%	Any	
R40, R41	DNI	Any	
R42	SMD resistor, 10 k Ω , 1/8 W, 1%	Any	
SW1	Switch slide, single-pole, double-throw, 30 V, 0.2 A	E-Switch	EG1218
TP1 to TP7, TP10, TP13 to TP16, TP18, TP19	PC test points, mini SMD	Keystone	5019
TP8	PC test point, mini SMD, PGND2	Keystone	5019
TP9	PC test point, mini SMD, GND	Keystone	5019
TP17	PC test point, mini SMD, PGND1	Keystone	5019
T1	Transformer	Pulse	PA1736NL
U1	Isolated controller	Analog Devices	ADP1071-2

**ESD Caution**

ESD (electrostatic discharge) sensitive device. Charged devices and circuit boards can discharge without detection. Although this product features patented or proprietary protection circuitry, damage may occur on devices subjected to high energy ESD. Therefore, proper ESD precautions should be taken to avoid performance degradation or loss of functionality.

Legal Terms and Conditions

By using the evaluation board discussed herein (together with any tools, components documentation or support materials, the "Evaluation Board"), you are agreeing to be bound by the terms and conditions set forth below ("Agreement") unless you have purchased the Evaluation Board, in which case the Analog Devices Standard Terms and Conditions of Sale shall govern. Do not use the Evaluation Board until you have read and agreed to the Agreement. Your use of the Evaluation Board shall signify your acceptance of the Agreement. This Agreement is made by and between you ("Customer") and Analog Devices, Inc. ("ADI"), with its principal place of business at One Technology Way, Norwood, MA 02062, USA. Subject to the terms and conditions of the Agreement, ADI hereby grants to Customer a free, limited, personal, temporary, non-exclusive, non-sublicensable, non-transferable license to use the Evaluation Board FOR EVALUATION PURPOSES ONLY. Customer understands and agrees that the Evaluation Board is provided for the sole and exclusive purpose referenced above, and agrees not to use the Evaluation Board for any other purpose. Furthermore, the license granted is expressly made subject to the following additional limitations: Customer shall not (i) rent, lease, display, sell, transfer, assign, sublicense, or distribute the Evaluation Board; and (ii) permit any Third Party to access the Evaluation Board. As used herein, the term "Third Party" includes any entity other than ADI, Customer, their employees, affiliates and in-house consultants. The Evaluation Board is NOT sold to Customer; all rights not expressly granted herein, including ownership of the Evaluation Board, are reserved by ADI. CONFIDENTIALITY. This Agreement and the Evaluation Board shall all be considered the confidential and proprietary information of ADI. Customer may not disclose or transfer any portion of the Evaluation Board to any other party for any reason. Upon discontinuation of use of the Evaluation Board or termination of this Agreement, Customer agrees to promptly return the Evaluation Board to ADI. ADDITIONAL RESTRICTIONS. Customer may not disassemble, decompile or reverse engineer chips on the Evaluation Board. Customer shall inform ADI of any occurred damages or any modifications or alterations it makes to the Evaluation Board, including but not limited to soldering or any other activity that affects the material content of the Evaluation Board. Modifications to the Evaluation Board must comply with applicable law, including but not limited to the RoHS Directive. TERMINATION. ADI may terminate this Agreement at any time upon giving written notice to Customer. Customer agrees to return to ADI the Evaluation Board at that time. LIMITATION OF LIABILITY. THE EVALUATION BOARD PROVIDED HEREUNDER IS PROVIDED "AS IS" AND ADI MAKES NO WARRANTIES OR REPRESENTATIONS OF ANY KIND WITH RESPECT TO IT. ADI SPECIFICALLY DISCLAIMS ANY REPRESENTATIONS, ENDORSEMENTS, GUARANTEES, OR WARRANTIES, EXPRESS OR IMPLIED, RELATED TO THE EVALUATION BOARD INCLUDING, BUT NOT LIMITED TO, THE IMPLIED WARRANTY OF MERCHANTABILITY, TITLE, FITNESS FOR A PARTICULAR PURPOSE OR NON-INFRINGEMENT OF INTELLECTUAL PROPERTY RIGHTS. IN NO EVENT WILL ADI AND ITS LICENSORS BE LIABLE FOR ANY INCIDENTAL, SPECIAL, INDIRECT, OR CONSEQUENTIAL DAMAGES RESULTING FROM CUSTOMER'S POSSESSION OR USE OF THE EVALUATION BOARD, INCLUDING BUT NOT LIMITED TO LOST PROFITS, DELAY COSTS, LABOR COSTS OR LOSS OF GOODWILL. ADI'S TOTAL LIABILITY FROM ANY AND ALL CAUSES SHALL BE LIMITED TO THE AMOUNT OF ONE HUNDRED US DOLLARS (\$100.00). EXPORT. Customer agrees that it will not directly or indirectly export the Evaluation Board to another country, and that it will comply with all applicable United States federal laws and regulations relating to exports. GOVERNING LAW. This Agreement shall be governed by and construed in accordance with the substantive laws of the Commonwealth of Massachusetts (excluding conflict of law rules). Any legal action regarding this Agreement will be heard in the state or federal courts having jurisdiction in Suffolk County, Massachusetts, and Customer hereby submits to the personal jurisdiction and venue of such courts. The United Nations Convention on Contracts for the International Sale of Goods shall not apply to this Agreement and is expressly disclaimed.

Mouser Electronics

Authorized Distributor

Click to View Pricing, Inventory, Delivery & Lifecycle Information:

[Analog Devices Inc.:](#)

[ADP1071-2EBZ12.1V](#)