

DESCRIPTION: MALE - DIP SOLDER - MACHINED - ECONOMY

No. OF PINS	DIMENSIONS					
	A	B	C	D	E	F
9	1.213	0.984	0.666	0.329	0.236	0.496
	30.80	24.99	16.92	8.36	5.99	12.60
15	1.541	1.312	0.994	0.329	0.236	0.496
	39.15	33.32	25.25	8.36	5.99	12.60
25	2.087	1.852	1.534	0.329	0.236	0.496
	53.00	47.04	38.96	8.36	5.99	12.60

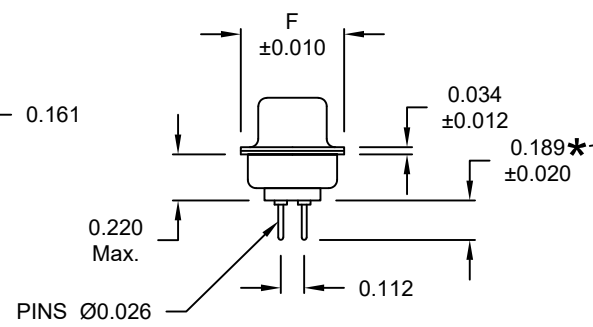
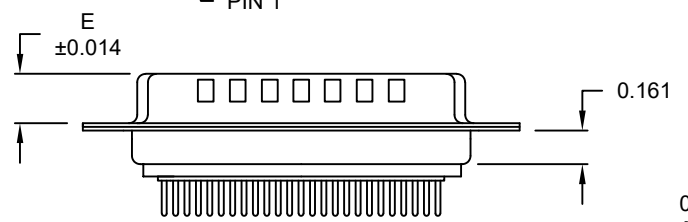
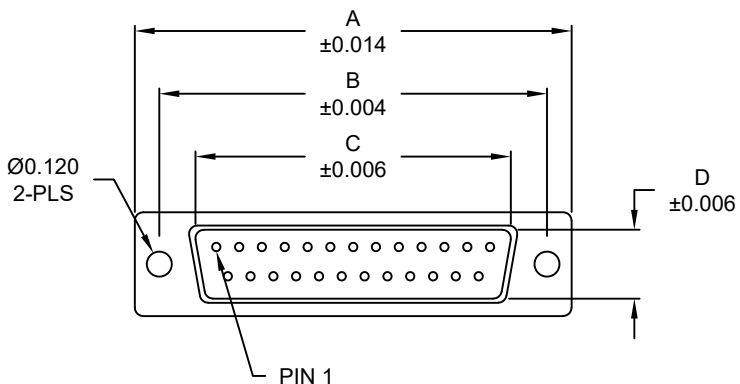

772-EYY-1 1 3 R YY 1

SERIES _____
 POSITIONS _____
 E09 _____
 E15 _____
 E25 _____
 GENDER _____
 1 = MALE _____
 * CONTACT LENGTH _____
 1 = 0.189" TAILS _____
 C = 0.248" TAILS _____
 D = 0.394" TAILS [10mm] _____
 SHELL PLATING _____
 3 = NICKEL (GROUND INDENTS) _____
 RoHS COMPLIANT _____
 HARDWARE OPTIONS _____
 00 = NO HARDWARE _____
 01 = 0.098" 4-40 INSERT, BOARD SIDE _____
 05 = 0.237" 4-40 BOARD LOCK, BOARD SIDE _____
 PLATING OPTIONS _____
 1 = GOLD FLASH _____
 2 = 30u" GOLD _____

MATERIAL:

- SHELL: STEEL, NICKEL PLATED
- INSULATOR: GLASS-FILLED NYLON THERMOPLASTIC, UL94 V-0
- PROCESS TEMP.: 260° C
- CONTACT: BRASS
- SEALING MATERIAL: F08 FLEXIBLE ADHESIVE

ELECTRICAL:

- CURRENT RATING: 5 AMPS
- CONTACT RESISTANCE: 15 mOhms Max.
- INSULATION RESISTANCE: 1,000 MOhms min.
- WORKING VOLTAGE: 250VAC
- TEMPERATURE: -55° C TO 125° C

MEETS IP67 STANDARDS

(SEE PAGE 3 FOR SEALING DETAILS)

UNITS = inch [mm]

DO NOT SCALE FROM DRAWING

RoHS COMPLIANT

	THESE DRAWINGS AND SPECIFICATIONS ARE THE PROPERTY OF NorComp AND SHALL NOT BE REPRODUCED, COPIED OR USED AS THE BASIS FOR THE MANUFACTURE OF SALE OF APPARATUS WITHOUT WRITTEN PERMISSION.		DRAWN: PAM JENKINS	DATE: 9-18-08
	<h1>NorComp</h1>		SCALE: NTS	SHEET OF 1 3
DWG NO. 772-EYY-113RYY1				

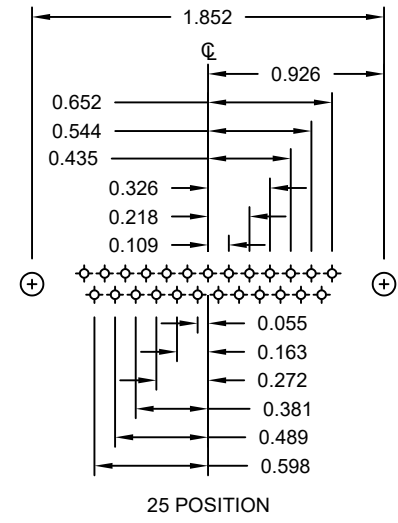
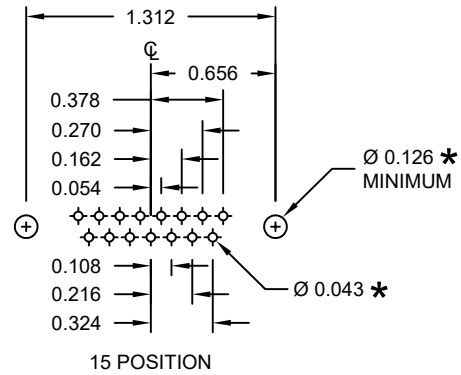
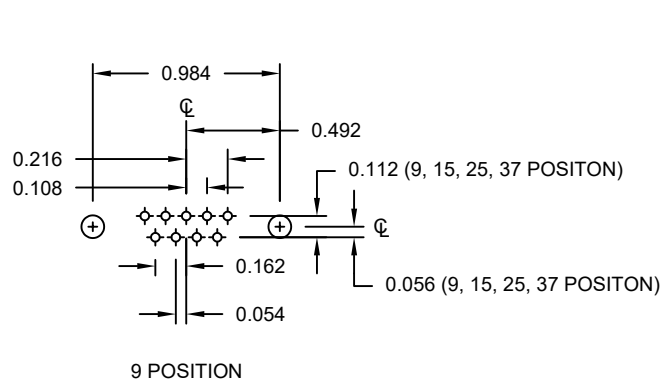

UNITS = inch

* TYP.
SUGGESTED SIZE
MAY NOT BE SUITABLE FOR ALL APPLICATIONS

DO NOT SCALE FROM DRAWING

	THESE DRAWINGS AND SPECIFICATIONS ARE THE PROPERTY OF NorComp AND SHALL NOT BE REPRODUCED, COPIED OR USED AS THE BASIS FOR THE MANUFACTURE OF SALE OF APPARATUS WITHOUT WRITTEN PERMISSION.		DRAWN: PAM JENKINS	DATE: 9-18-08
	NorComp		SCALE: NTS	SHEET OF 2 3
DWG NO. 772-EYY-113RYY1				

DESCRIPTION: IP67 - MALE - SOLDER CUP - MACHINED - ECONOMY - SEALING PROCESS

HARDWARE OPTIONS

ALL CLINCH-NUTS ARE 4-40 INTERNAL THREADS

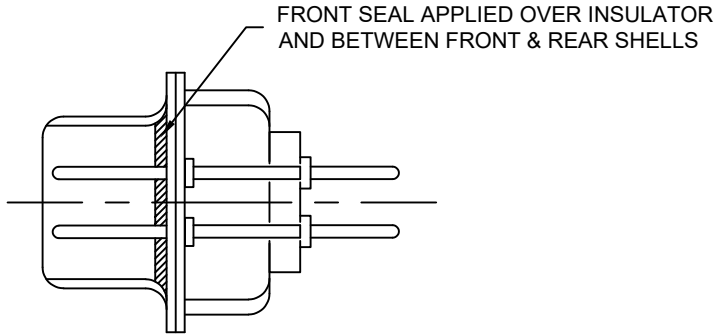
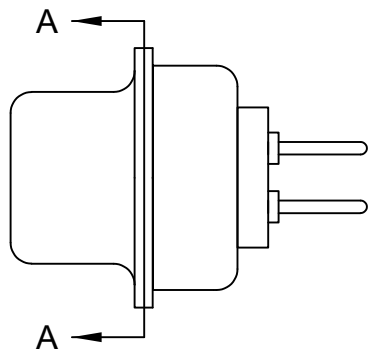

DETAIL A-A

01X 0.098" (BOARD SIDE)

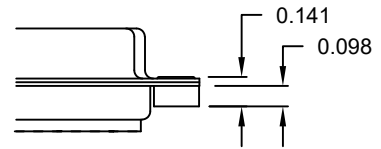

05X 0.237" (BOARD SIDE)

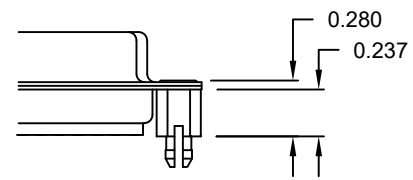

UNITS = inch [mm]

DO NOT SCALE FROM DRAWING

	THESE DRAWINGS AND SPECIFICATIONS ARE THE PROPERTY OF NorComp AND SHALL NOT BE REPRODUCED, COPIED OR USED AS THE BASIS FOR THE MANUFACTURE OF SALE OF APPARATUS WITHOUT WRITTEN PERMISSION.		DRAWN: PAM JENKINS	DATE: 9-18-08
	<h1>NorComp</h1>		SCALE: NTS	SHEET 3 OF 3
DWG NO. 772-EYY-113RYY1				

Mouser Electronics

Authorized Distributor

Click to View Pricing, Inventory, Delivery & Lifecycle Information:

[NorComp:](#)

[772-E09-113R001](#) [772-E15-113R001](#) [772-E25-113R001](#) [772-E15-113R011](#) [772-E15-113R051](#) [772-E25-113R011](#)
[772-E25-113R051](#) [772-E09-113R051](#) [772-E09-113R011](#)