

Corrugated Loom Tubing

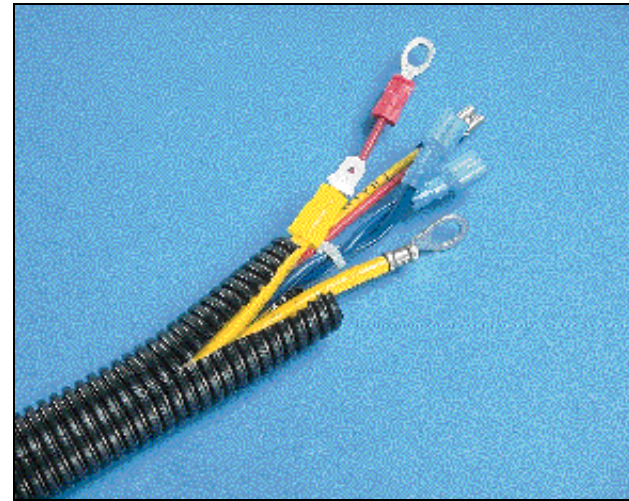

APPLICATIONS

- Protect wires from abrasion
- Route and manage a variety of wires and cables, including fiber optic
- Bundle wires in control panels
- Contain and organize wire harnesses
- Route wires in automotive, truck, trailer, conversion van, recreational vehicle and marine industries

FEATURES

- Impact and crush resistant
- Available in slit and solid wall design
- Available in standard colors of yellow and orange
- Available in polyethylene and heat stabilized nylon

BENEFITS

- Provides excellent abrasion resistance
- Easy installation for applications with and without breakouts
- Useful for identification of fiber optic applications
- Can be used in many applications

Abrasion Protection Materials Technical Data For Corrugated Loom Tubing	Ratings & Approvals			Physical Properties		Chemical Resistance			
	UL Temperature Index	Flammability (UL 94)	Melting Temperature	Specific Gravity (d792)	Minimum Tensile @ 23° C (psi)	Organic Solvents	Alkalies	Acids	Petro-Chemicals
Black Polyethylene Economic material suitable for continuous use at temperatures of -40° F (-40° C) to 176° F (80° C).	N/A	HB	266° F (130° C)	.926	1529 (D638)	Excellent	Excellent	Excellent	Good
Heat Stabilized Black Nylon Nylon is a strong, durable, high abrasion resistant material for continuous use at temperatures of -40° F (-40° C) to 248° F (120° C).	N/A	HB	437° F (225° C)	1.06-1.16	10,000 (D638)	Excellent	Good	Fair	Good

NOTE: Typical operating temperature ranges are extended based on end use application and specific environmental tests.

The Functional Part Number System Makes Ordering Easy

Corrugated Loom Tubing Part Number Description

Example: **CLT 100 N-C 630**

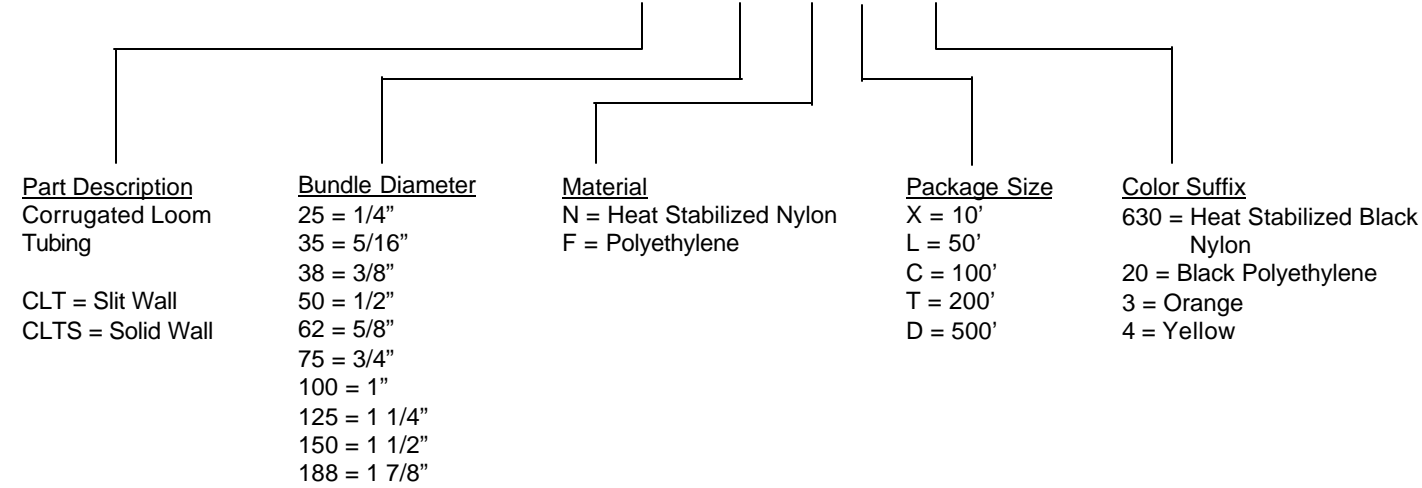

Ordering Information - Corrugated Loom Tubing

PANDUIT® Part Number		Material	Color	Inside Diameter	Outside Diameter	Feet Per Pkg.	Pkg. Qty.*			
Slit	Solid									
CLT25F-C20	CLTS25F-C	Polyethylene	Black	.265" (6.7)	.390" (9.9)	100'	1 Roll			
CLT35F-C20	CLTS35F-C			.350" (8.9)	.500" (12.7)					
CLT38F-C20	CLTS38F-C			.414" (10.5)	.556" (14.1)					
CLT50F-C20	CLTS50F-C			.505" (12.8)	.670" (17.0)					
CLT62F-C20	CLTS62F-C			.665" (16.9)	.830" (21.1)					
CLT75F-C20	CLTS75F-C			.760" (19.3)	.935" (23.7)					
CLT100F-C20	CLTS100F-C			.915" (23.2)	1.090" (27.7)					
CLT125F-L20	CLTS125F-L			1.290" (32.8)	1.500" (38.1)					
CLT150F-X20	**			1.550" (39.1)	1.860" (47.2)					
CLT150F-T20	**			1.550" (39.1)	1.860" (47.2)					
CLT188F-X20	CLTS150F-D			1.881" (47.8)	2.169" (55.1)					
CLT188F-C20	**			1.881" (47.8)	2.169" (55.1)					
CLT188F-6C20	**			1.881" (47.8)	2.169" (55.1)					
CLT25F-C3	CLTS25F-C3			Polyethylene	Orange	.265" (6.7)		.390" (9.9)	100'	1 Roll
CLT35F-C3	CLTS35F-C3					.350" (8.9)		.500" (12.7)		
CLT38F-C3	CLTS38F-C3					.414" (10.5)		.556" (14.1)		
CLT50F-C3	CLTS50F-C3	.505" (12.8)	.670" (17.0)							
CLT62F-C3	CLTS62F-C3	.665" (16.9)	.830" (21.1)							
CLT75F-C3	CLTS75F-C3	.760" (19.3)	.935" (23.7)							
CLT100F-C3	CLTS100F-C3	.915" (23.2)	1.090" (27.7)							
CLT125F-C3	CLTS125F-C3	1.290" (32.8)	1.500" (38.1)							
CLT150F-X3	**	1.550" (39.1)	1.860" (47.2)							
CLT150F-T3	**	1.550" (39.1)	1.860" (47.2)							
CLT150F-D3	CLTS150F-D3	1.550" (39.1)	1.860" (47.2)							
CLT188F-X3	**	1.881" (47.8)	2.169" (55.1)							
CLT188F-C3	**	1.881" (47.8)	2.169" (55.1)							
CLT188F-6C3	**	1.881" (47.8)	2.169" (55.1)							
CLT125F-L4	**	Polyethylene	Yellow			1.290" (32.8)	1.500" (38.1)	50'	1 Roll	
CLT150F-X4	**					1.550" (39.1)	1.860" (47.2)			
CLT150F-T4	**			1.550" (39.1)	1.860" (47.2)					
CLT150F-D4	**			1.550" (39.1)	1.860" (47.2)					
CLT188F-X4	**			1.881" (47.8)	2.169" (55.1)					
CLT188F-C4	**			1.881" (47.8)	2.169" (55.1)					
CLT188F-6C4	**	1.881" (47.8)	2.169" (55.1)							
CLT25N-C630	CLTS25N-C	Heat Stabilized Black Nylon	Black	.265" (6.7)	.390" (9.9)	100'	1 Roll			
CLT35N-C630	CLTS35N-C			.350" (8.9)	.500" (12.7)					
CLT38N-C630	CLTS38N-C			.414" (10.5)	.556" (14.1)					
CLT50N-C630	CLTS50N-C			.505" (12.8)	.670" (17.0)					
CLT62N-C630	CLTS62N-C			.665" (16.9)	.830" (21.1)					
CLT75N-C630	CLTS75N-C			.760" (19.3)	.935" (23.7)					
CLT100N-C630	CLTS100N-C			.915" (23.2)	1.090" (27.7)					
CLT125N-L630	CLTS125N-L			1.290" (32.8)	1.500" (38.1)					
CLT150N-D630	CLTS150N-D			1.550" (39.1)	1.860" (47.2)					
CLT188N-6C630	**			1.881" (47.8)	2.169" (55.1)					

*Order number of rolls required.
 **Contact factory for additional sizes, materials, colors, and bulk packaging.
 NOTE: Custom cut-to-length sizes are available upon request. Contact factory for details.



Corrugated Loom Tubing Fittings

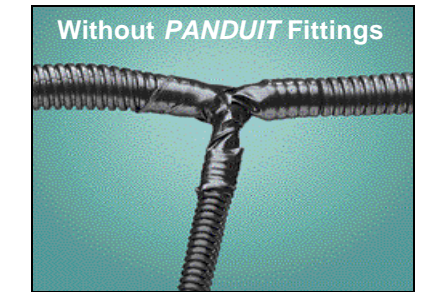
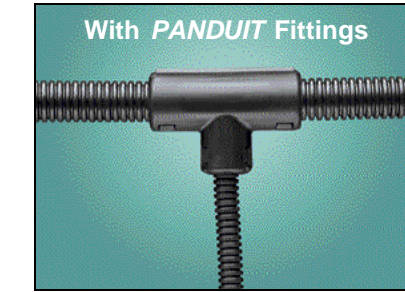

FEATURES

- Fast assembly
- Virtually eliminates taping
- Easy to assemble
- Locking latch design
- Durable polyethylene shell
- Works with most popular sizes of Corrugated Loom Tubing

BENEFITS

- Reduces production time
- Improves system appearance
- Reduces operator fatigue
- Secures fittings firmly in place
- Protects wires
- Provides easy selection of fittings for an application

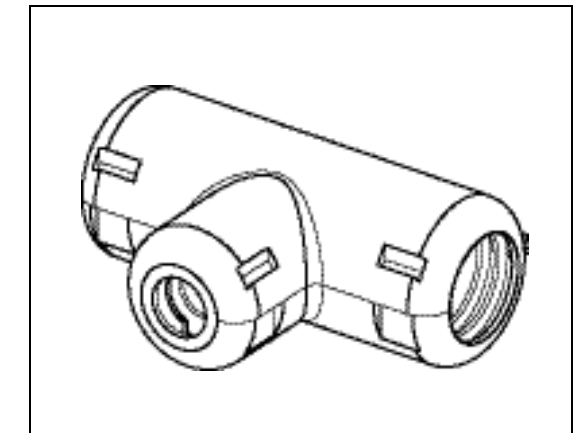
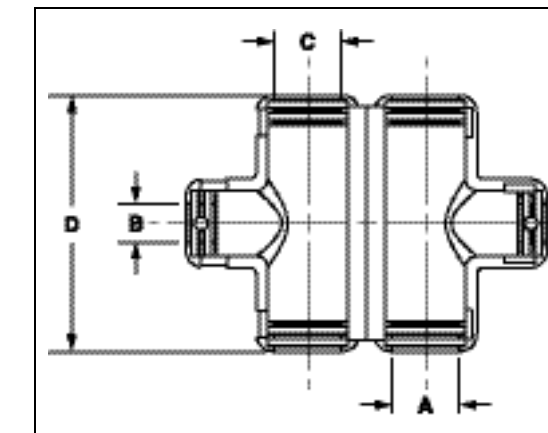

Ordering Information - Corrugated Loom Tubing Fittings

Part Number	A	B	C	D	Material	Color	Std. Pkg	Std. Ctn.
CF382538F-Q	.375	.250	.375	2.06	Polyethylene	Black	25	100
CF502550F-Q	.500	.250	.500	2.30	Polyethylene	Black	25	100
CF503850F-Q	.500	.375	.500	2.30	Polyethylene	Black	25	100
CF752575F-Q	.750	.250	.750	3.06	Polyethylene	Black	25	100
CF753875F-Q	.750	.375	.750	3.06	Polyethylene	Black	25	100

Products for Specific Use with Corrugated Loom Tubing

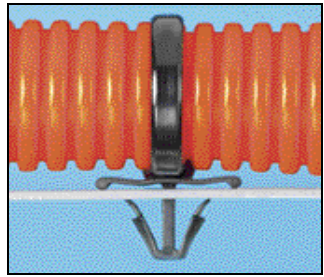

PAN-TY®
Center Mounted
Heat Stabilized
Nylon 6.6 Wing
Push Mount Ties
(PLWP)

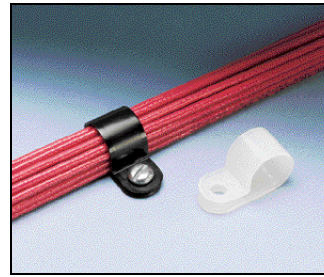

Fixed Diameter
Cable Clamps
(CCS, CCH)

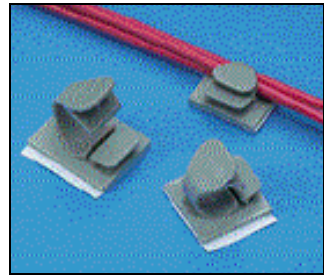

Latching Wire Clip
Adhesive Backed
Mounting Device
(LWC)

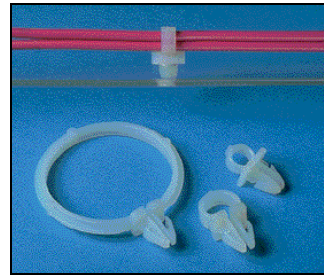

Snap-In Clips
(SICH)

PANDUIT® Part #	Corrugated Loom Tubing
PLUP40SE-D30	Any Size Applies
PLWP40SD-D30	Any Size Applies
PLWP50SE-D30	Any Size Applies
LWC38-A-C	CLT25F-C20
LWC50-A-C	CLT38F-C20
LWC75-A-C	CLT50F-C20
LWC100-A-C	CLT100F-C20
SICH50-C	CLT25F-C20
SICH75-C	CLT50F-C20
SICH100-C	CLT75F-C20
SICH150-C	CLT125F-C20
CCS38-S8-C	CLT25F-C20
CCS50-S8-C	CLT38F-C20
CCH62-S10-C	CLT50F-C20
CCH75-S10-C	CLT50F-C20
CCH100-S10-C	CLT100F-C20
CCH125S10-C	CLT100F-L20
CCH150S10-C	CLT125F-D20

Other Abrasion Protection Products From PANDUIT

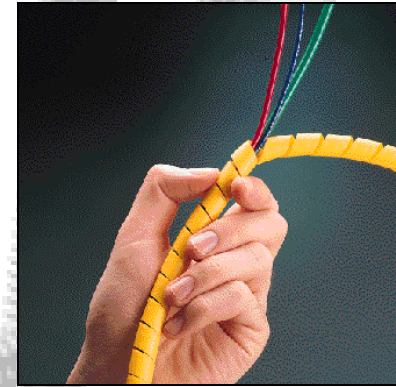

Spiral Wrap

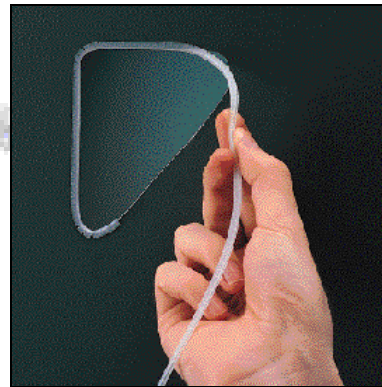

Grommet Edging

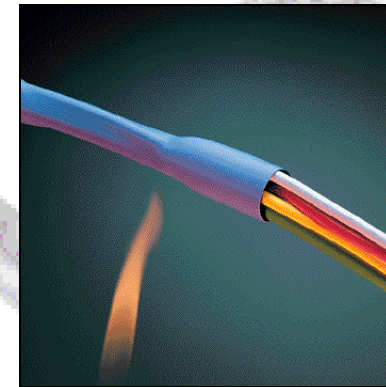

Heat Shrink
Tubing

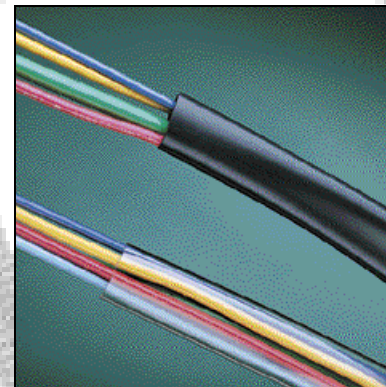

PVC Tubing

(Ask For Heat Shrink/Abrasion Protection Catalog SA101N48F-AIS)



Braided Sleeving



PRODUCT BULLETIN

Corrugated Loom Tubing and Fittings

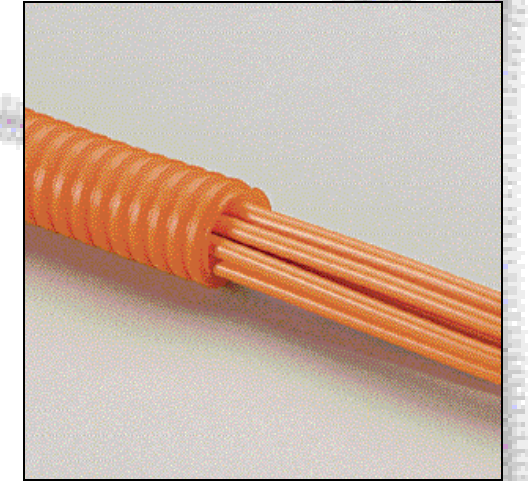
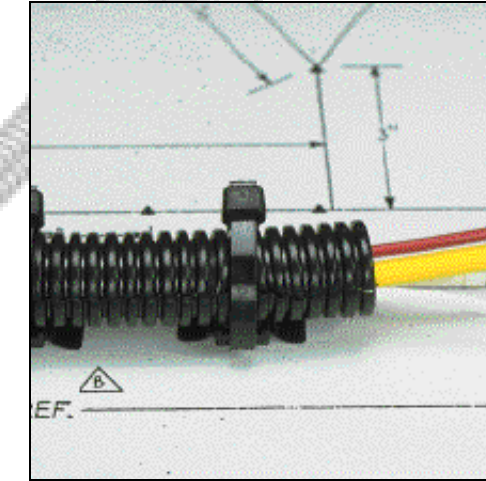

PANDUIT® offers a full-line of Corrugated Loom Tubing and Fittings for wire harness and cable applications. Corrugated Loom Tubing (CLT) provides users with an economical solution that features efficient installation and complete abrasion protection. Available in heat stabilized nylon and polyethylene materials, CLT is suitable for a wide range of environments. It is also available in both slit and solid wall construction to facilitate easy installation in a variety of applications. PANDUIT's new line of Fittings provide a secure way to join CLT at junctions and breakouts while improving the appearance of wire harnesses.

Our products are warranted to be free from defects in material and workmanship at the time of sale but our obligation under this warranty is limited to the replacement of any product proven to be defective within 6 months (for product) or 90 days (for tools) from the date of delivery. Tool warranty is void if PANDUIT/Tools are modified, altered or misused in any way. Use of Panduit tooling with any product other than the specified Panduit products for which the tool was designed, constitutes misuse. Before using, user shall determine the suitability of the product for his intended use and user assumes all risk and liability whatsoever in connection therewith.



Panduit Corp.
17301 Ridgeland Avenue
Tinley Park, IL 60477-3091
Phone: 800-777-3300
Fax: 770-781-9076
Email: info@panduit.com
Website: www.panduit.com

Panduit Canada
Div. of Panduit Corp.
140 Amber Street
Markham, Ontario L3R 3J8
Phone: 800-387-9689
Fax: 905-475-6998

WORLDWIDE SUBSIDIARIES AND SALES OFFICES

This warranty is made in lieu of and excludes all other warranties, expressed or implied. THE IMPLIED WARRANTIES OF MERCHANTABILITY AND FITNESS FOR A PARTICULAR USE ARE SPECIFICALLY EXCLUDED. Neither seller nor manufacturer shall be liable for any other injury, loss or damage, whether direct or consequential, arising out of the use of, or the inability to use, the product.

The information contained in this literature is based on our experience to date and is believed to be reliable. It is intended as a guide for use by persons having technical skill at their own discretion and risk. We do not guarantee favorable results or assume any liability in connection with its use. Dimensions contained herein are for reference purposes only. For specific dimensional requirements consult the factory. This publication is not to be taken as a license to operate under, or a recommendation to infringe any existing patents. This supersedes and voids all previous literature, etc.

For Pricing and Further Information -
Contact your local
PANDUIT Distributor or Sales Office

SA-WA04CB01D
Printed in the U.S.A.

Copyright © 2001 Panduit Corp. All Rights Reserved.