

Installation Instructions

Original Instructions



Ultrasonic Sensors

Bulletin Number 873P



Specifications

Attribute	873P-D18x-400-Dy ⁽¹⁾	873P-D18x-900-Dy ⁽¹⁾	873P-D18x-2200-Dy ⁽¹⁾	873P-D30x-2500-Dy ⁽¹⁾	873P-D30x-3500-Dy ⁽¹⁾	873P-D30x-6000-Dy ⁽¹⁾
Certification	c-UL-us Listed and CE Marked for all applicable directives					
Rated sensing distance [mm (in.)]	50...400 (1.97...15.75) ⁽²⁾	100...900 (3.94...35.43) ⁽²⁾	200...2200 (7.87...86.61) ⁽²⁾	200...2500 (7.87...98.42) ⁽²⁾	250...3500 (9.84...137.79) ⁽²⁾	350...6000 (13.78...236.22) ⁽³⁾
Teachable sensing range [mm (in.)]	50...400 (1.97...15.75)	100...900 (3.94...35.43)	200...2200 (7.87...86.61)	200...2500 (7.87...98.42)	250...3500 (9.84...137.79)	350...6000 (13.78...236.22)
Blind zone [mm (in.)]	0...50 (0...1.97)	0...100 (0...3.94)	0...200 (0...7.87)	0...200 (0...7.87)	0...250 (0...9.84)	0...350 (0...13.78)
Beam angle	15°±2°	14°±2°	14°±2°	10°±2°	12°±2°	15°±2°
Sensitivity adjustment	Push button					
Linearity	1%			<3%		
Resolution (SIO) [mm (in.)]	1 (0.04)	2 (0.08)	3 (0.12)	2 (0.08)	4 (0.16)	6 (0.24)
Resolution (IO-link)	1 mm					
Accuracy	0.50%			1%		
Hysteresis	<1%			<3%		
Ripple	5%					
Operating voltage	10...30V DC					
Current consumption	<50 mA			<30 mA		
Protection type	<ul style="list-style-type: none"> • Short circuit • Reverse polarity • Transient noise • Overload 					
Output current	100 mA					
Leakage current	≤10 μA					
Transducer frequency	300 kHz	300 kHz	200 kHz	150 kHz	112 kHz	75 kHz
Output voltage drop, max	2.2V					
Output type	<ul style="list-style-type: none"> • P1 Model: PNP or IO-Link • P2 Model: Dual PNP or IO-Link • AI Model: Analog Current or IO-Link • AV Model: Analog Voltage or IO-Link • AIP2 Model: Dual PNP and Analog Current or IO-Link • AVP2 Model: Dual PNP and Analog Voltage or IO-Link 					
Switching frequency	10 Hz	3 Hz	2 Hz	1 Hz		
Time delay before availability (Digital Output)	600 ms					
Response time (Analog Output)	400 ms			450 ms		
Time delay before availability (Analog Output)	650 ms			600 ms		
Temperature range	-20...+70 °C (-4...+158 °F)					
Temperature compensation	Yes					
Temperature drift	±2%			±5%		
Material	<ul style="list-style-type: none"> • Housing: Plastic - PBT • Active head: Epoxy - glass resin 					
Ingress protection rating	IP67					

- (1) Replace the x with P1, P2, AI, AV, AIP2, AVP2.
If x is P1, replace the y with D4 (Micro QD, 4-pin). Replace the y with D5 (Micro QD, 5-pin) for all other models.
- (2) Metallic target 200 x 200 mm (7.87 x 7.87 in.)
- (3) Metallic target 400 x 400 mm (15.75 x 15.75 in.)

Dual-switching and/or Analog Output

In this sensing mode, you teach the sensor two switching points: P1 is the first taught point and P2 is the second taught point. For dual discrete switching outputs, P1 defines the switching point of Pin-4 outputs and P2 defines the switching point of Pin-2 outputs. For analog output, P1 determines 4 mA or 0V position and P2 determines 20 mA or 10V position. Output logic, Normally Open (N.O.) or Normally Closed (N.C.), is defined based on teaching sequence of the near setpoint and far setpoint: teach the near setpoint first for a N.O./rising ramp output; teach the far setpoint first for a N.C./falling ramp output. The analog output is scaled between the two taught points (P1 and P2).

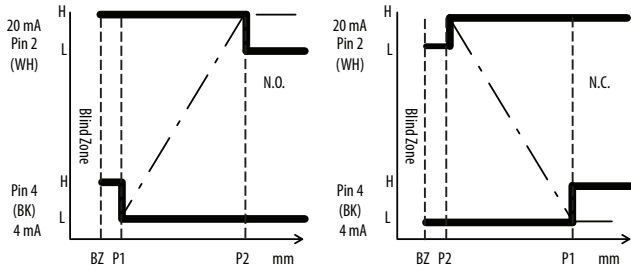

Setpoint 1

- Place the target at the desired near/far setpoint.
 - Teaching the near setpoint first yields an N.O./rising ramp output.
 - Teaching the far setpoint first yields an N.C./falling ramp output.
- With the target still in place, press and release the Teach button. The yellow and green status indicators flash simultaneously, which indicates that the first setpoint (P1) is set. The sensor is waiting for the second setpoint (P2).

Setpoint 2

- Place the target at the desired near/far setpoint.
- Press and release the Teach button while the green and yellow status indicators stop flashing. The sensor is ready to operate.

Single-switching and/or Analog Output

In this sensing mode, one switching point is taught within the defined sensing range of the sensor. The working range of the sensor becomes the minimum sensing distance (blind zone) to a user-taught setpoint. Depending on where the setpoint is taught, the output turns ON when the target passes between the minimum sensing distance and the taught setpoint. The analog output is scaled between minimum sensing distance and taught setpoint. When using the single-switching output mode, it is only possible to configure the sensor for Normally Open logic and rising ramp analog output.

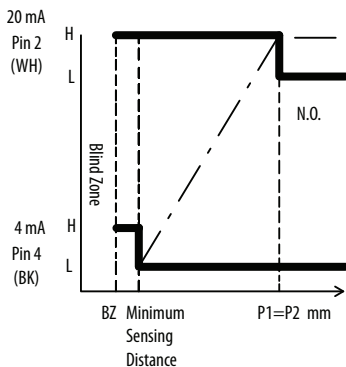

Setpoint

- Place the target at the desired setpoint.
- With the target still in place, press and release the Teach button. The yellow and green status indicators flash simultaneously, which indicates that the first setpoint (P1) is now set. The sensor is waiting for the second setpoint. Keep the target and sensor in the same position, and press and release the Teach button again to set the second setpoint (P2). The yellow status indicator turns off and the green status indicator stops flashing, which indicates that the sensor is ready for use. The minimum sensing distance is shown in [Specifications on page 1](#).

IMPORTANT

When you configure the sensor for single-switching mode, it is important that the target is at the exact same distance for both the first and second push of the Teach button. If the target or sensor has moved even slightly, the detected ranges are different for the two pushes of the Teach button, and the sensor is configured for dual-switching mode.

The green and yellow status indicators flash asynchronously for about 2 seconds, which indicates that there is no target present within the sensing range of the sensor and, therefore, no setpoint to teach. When no setpoint to teach occurs, the 873P sensor ignores the teach attempt and restores its previous settings. By comparison, when an object is detected during teach, the yellow and green status indicators flash synchronously and continue flashing until the second push of the Teach button.

Status Indicators

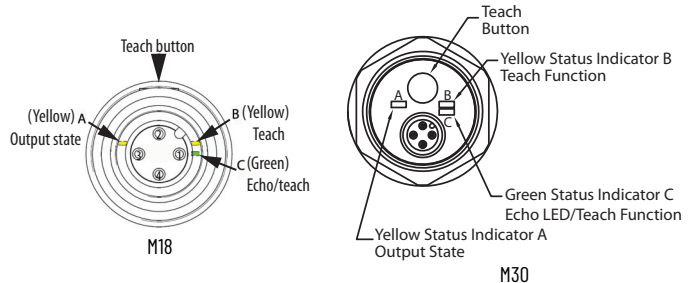

Double PNP Output Status Indicator Functions

Indicator	Color	Function
A	Yellow	P1 Point in double digital output
B	Yellow	P2 Point in double digital output/Teach function
C	Green	ECHO Indicator/Teach function

Dual PNP Discrete Output and One Analog Output Status Indicators ⁽¹⁾

Operating Model	Green Indicator (Alignment)	Yellow Indicator A (Output)	Yellow Indicator B (Teach)
Standard Operation			
Target Present	ON ⁽²⁾	ON/OFF ⁽³⁾	ON/OFF ⁽³⁾
Target Absent	ON/OFF ⁽²⁾	ON/OFF ⁽³⁾	ON/OFF ⁽³⁾

- The analog output depends on the user-taught setpoints for the dual discrete sensor. Therefore, it does not have a separate status indicator.
- Green status indicator indicates that an echo is reflected back to the sensor by an object, not necessarily the target. Primary use is alignment.
- For single discrete sensors, status indicator A triggers ON/OFF depending on target position relative to the taught setpoints and if N.O. or N.C. logic is used. For dual discrete sensors, status indicators A and B trigger ON/OFF depending on the target position relative to the taught setpoints and on the logic used (N.O. or N.C.).

Lockout Feature for Teach Button

The lockout feature locks the push button to help prevent unwanted teaching of the sensor.

Lock Teach Button

1. Press the Teach button for 8 seconds, until the yellow status indicators A and B flash alternately with the green status indicator C.
2. Release the Teach button.

The push button is now locked.

Unlock Teach Button

1. Press the Teach button for 8 seconds, until the yellow status indicators A and B flash alternately with the green status indicator C.
2. Release the Teach button.

It is once again possible to teach the sensor.

Synchronization of Ultrasonic Sensors

In this mode, all sensors are connected to a same output on the PLC. A SYNC pulse simultaneously drives all sensors that are connected to the PLC output. When mounting the sensors, pay attention to a minimum distance between the sensors; this distance varies depending on the types of sensors used (see [How it Works](#)). The target must be positioned at the same distance from each synchronized sensor; the target position should overall be flat. When mounted correctly, the synchronized sensors perform like one sensor with an extended detection angle.

IMPORTANT Sensor response times increase proportionally to the number of synchronized sensors.

How it Works

Connect Pin 2 (white) to all sensors to be synchronized.

All sensors trigger simultaneously. Any eventual crosstalk signal related to a longer sensing distance is ignored. An external synchronization pulse controls the sensors.

All minimum distances depend on target distance and material. "T" is the pulse time period that is applied on the SYNC wire, and "Width" refers to the pulse width.

- | | |
|--|--|
| <ul style="list-style-type: none"> • 400 mm sensing range sensors
T ≥ 4 ms
500 μs ≤ Width ≤ 1 ms
Minimum distance between sensors:
50...100 mm (1.97...3.94 in.) | <ul style="list-style-type: none"> • 2500 mm sensing range sensors
T ≥ 25 ms
500 μs ≤ Width ≤ 5 ms
Minimum distance between sensors:
100 mm (3.94 in.) for working distances up to 1.5 m (4.9 ft), and 50 mm (1.97 in.) for distances >1.5 m (4.9 ft). |
| <ul style="list-style-type: none"> • 900 mm sensing range sensors
T ≥ 7.5 ms
500 μs ≤ Width ≤ 1 ms
Minimum distance between sensors:
30...50 mm (1.18...1.97 in.) | <ul style="list-style-type: none"> • 3500 mm sensing range sensors
T ≥ 35 ms
500 μs ≤ Width ≤ 5 ms
Minimum distance between sensors:
100 mm (3.94 in.) for working distances up to 1.5 m (4.9 ft), and 50 mm (1.97 in.) for distances >1.5 m (4.9 ft). |
| <ul style="list-style-type: none"> • 2200 mm sensing range sensors
T ≥ 17.5 ms
500 μs ≤ Width ≤ 1 ms
Minimum distance between sensors:
30...40 mm (1.18...1.57 in.) | <ul style="list-style-type: none"> • 6000 mm sensing range sensors
T ≥ 60 ms
500 μs ≤ Width ≤ 1 ms
Minimum distance between sensors:
200 mm (7.87 in.) for working distances up to 1.5 m (4.9 ft), and 50 mm (1.97 in.) for distances >1.5 m (4.9 ft). |

Beam Diagrams

50...400 mm (1.97...15.75 in.) Sensing Range

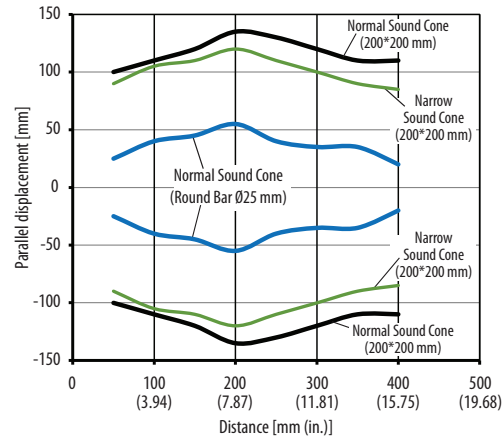

100...900 mm (3.94...35.43 in.) Sensing Range

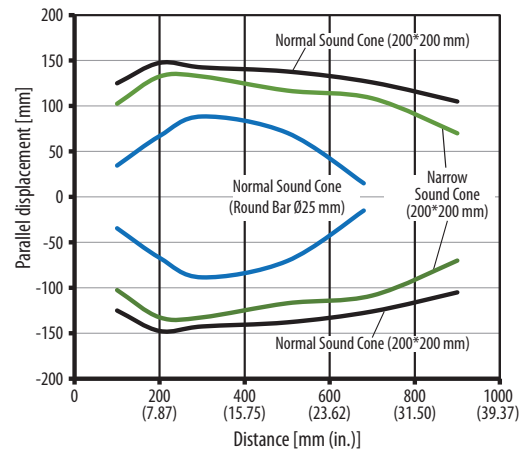

200...2200 mm (7.87...86.61 in.) Sensing Range

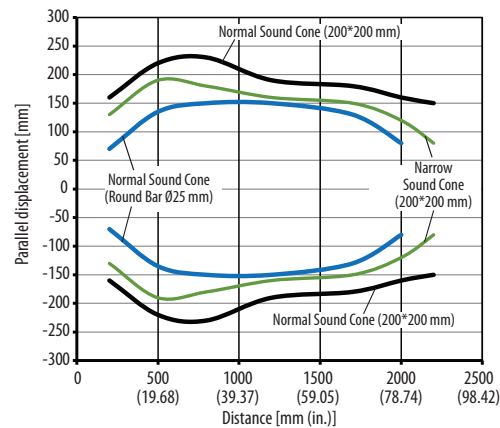

200...2500 mm (7.87...98.43 in.) Sensing Range

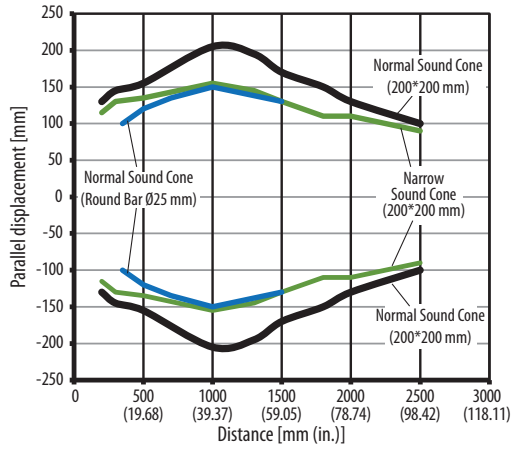

250...3500 mm (9.84...137.79 in.) Sensing Range

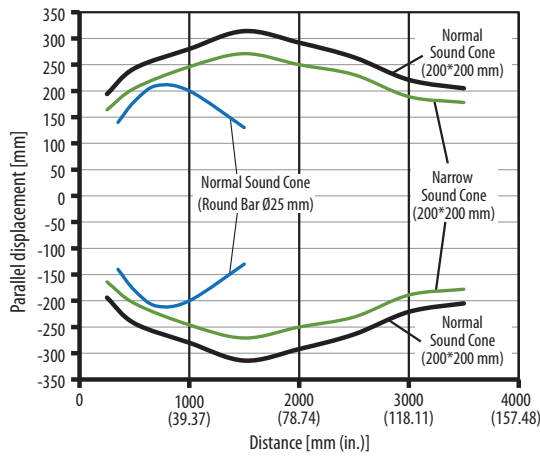

350...6000 mm (13.78...236.22 in.) Sensing Range

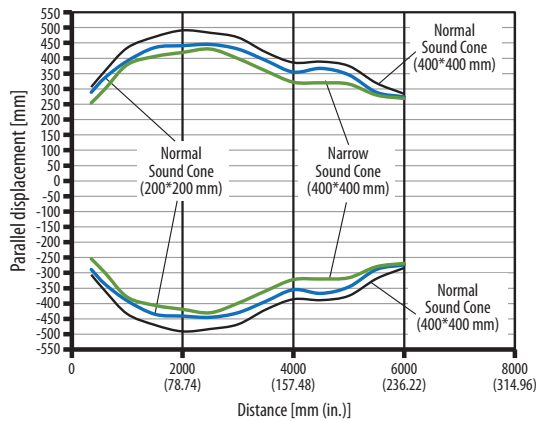

Wiring Diagrams

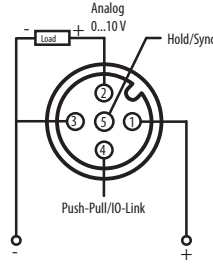

Single PNP and Analog Voltage Models

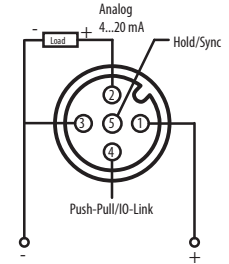

Single PNP and Analog Current Models

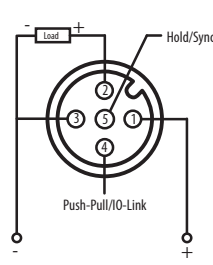

Dual PNP Models

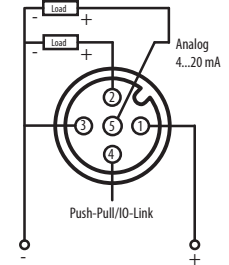

Dual PNP and Analog Current Models

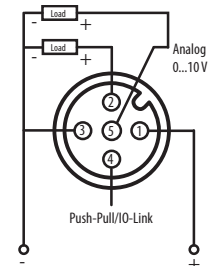

Dual PNP and Analog Voltage Models

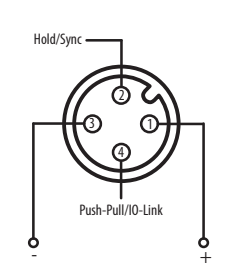

Single PNP Models

IMPORTANT Solid-state devices can be susceptible to radio frequency (RF) interference depending on the power and the frequency of the transmitting source. If RF transmitting equipment is to be used in the vicinity of the solid-state devices, thorough testing can be performed to verify that transmitter operation is restricted to a safe operating distance from the sensor equipment and its wiring.



ATTENTION: If a hazardous condition can result from unintended operation of this device, access to the sensing area can be guarded.

Approximate Dimensions

Dimensions shown in mm (in.).

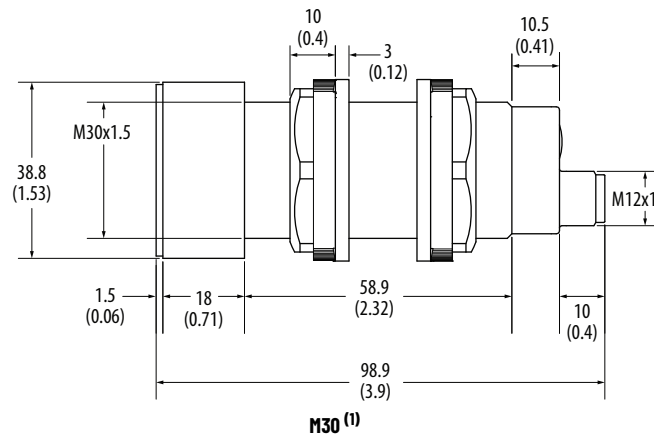
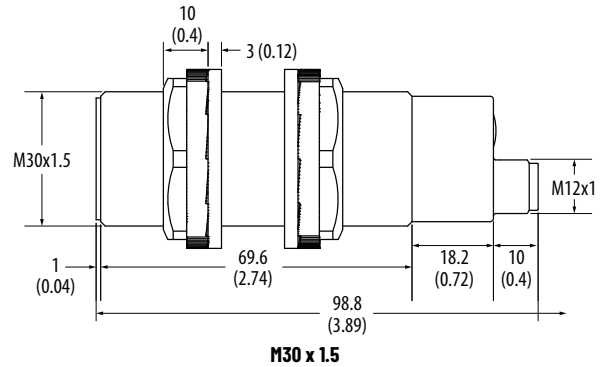
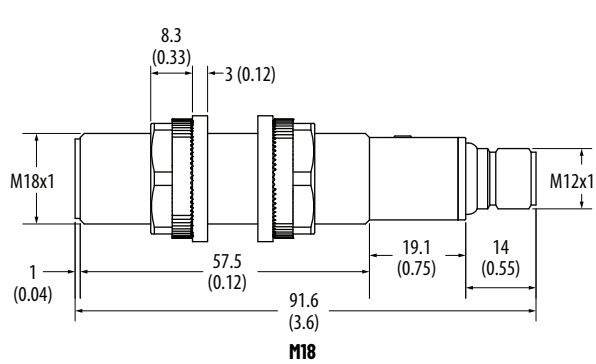

(1) 38.8 mm (1.53 in.) diameter, max

Additional Resources

These documents contain additional information concerning related products from Rockwell Automation.

Resource	Description
Ultrasonic Sensors with IO-Link Interface User Manual, publication 873P-UM001	Provides information to install, wire, and troubleshoot your 873P sensor.
Industrial Automation Wiring and Grounding Guidelines, publication 1770-4.1	Provides general guidelines for installing a Rockwell Automation industrial system.
Product Certifications website, rok.auto/certifications .	Provides declarations of conformity, certificates, and other certification details.

You can view or download publications at rok.auto/literature.

Rockwell Automation Support

Use these resources to access support information.

Technical Support Center	Find help with how-to videos, FAQs, chat, user forums, and product notification updates.	rok.auto/support
Knowledgebase	Access Knowledgebase articles.	rok.auto/knowledgebase
Local Technical Support Phone Numbers	Locate the telephone number for your country.	rok.auto/phonesupport
Literature Library	Find installation instructions, manuals, brochures, and technical data publications.	rok.auto/literature
Product Compatibility and Download Center (PCDC)	Download firmware, associated files (such as AOP, EDS, and DTM), and access product release notes.	rok.auto/pcdc

Documentation Feedback

Your comments help us serve your documentation needs better. If you have any suggestions on how to improve our content, complete the form at rok.auto/docfeedback.

Waste Electrical and Electronic Equipment (WEEE)







At the end of life, this equipment should be collected separately from any unsorted municipal waste.

Rockwell Automation maintains current product environmental compliance information on its website at rok.auto/pec.

Your comments help us serve your documentation needs better. If you have any suggestions on how to improve our content, complete the form at rok.auto/docfeedback.

For technical support, visit rok.auto/support.

Rockwell Otomasyon Ticaret A.Ş. Kar Plaza İş Merkezi E Blok Kat:6 34752 İçerenköy, İstanbul, Tel: +90 (216) 5698400 EEE Yönetmeliğine Uygundur

Connect with us.    

rockwellautomation.com — expanding **human possibility**[™]

AMERICAS: Rockwell Automation, 1201 South Second Street, Milwaukee, WI 53204-2496 USA, Tel: (1) 414.382.2000, Fax: (1) 414.382.4444

EUROPE/MIDDLE EAST/AFRICA: Rockwell Automation NV, Pegasus Park, De Kleetlaan 12a, 1831 Diegem, Belgium, Tel: (32) 2 663 0600, Fax: (32) 2 663 0640

ASIA PACIFIC: Rockwell Automation, Level 14, Core F, Cyberport 3, 100 Cyberport Road, Hong Kong, Tel: (852) 2887 4788, Fax: (852) 2508 1846

Allen-Bradley, expanding human possibility, and Rockwell Automation are trademarks of Rockwell Automation, Inc.

Trademarks not belonging to Rockwell Automation are property of their respective companies.

Publication 873P-IN006A-EN-P - October 2020

Copyright © 2020 Rockwell Automation, Inc. All rights reserved. Printed in the U.S.A.

10005775215 Ver 01