

**INA141**

## Precision, Low Power, G = 10, 100 INSTRUMENTATION AMPLIFIER

### FEATURES

- **LOW OFFSET VOLTAGE:** 50 $\mu$ V max
- **LOW DRIFT:** 0.5 $\mu$ V/ $^{\circ}$ C max
- **ACCURATE GAIN:**  $\pm$ 0.05% at G = 10
- **LOW INPUT BIAS CURRENT:** 5nA max
- **HIGH CMR:** 117dB min
- **INPUTS PROTECTED TO  $\pm$ 40V**
- **WIDE SUPPLY RANGE:**  $\pm$ 2.25 to  $\pm$ 18V
- **LOW QUIESCENT CURRENT:** 750 $\mu$ A
- **8-PIN PLASTIC DIP, SO-8**

### APPLICATIONS

- BRIDGE AMPLIFIER
- THERMOCOUPLE AMPLIFIER
- RTD SENSOR AMPLIFIER
- MEDICAL INSTRUMENTATION
- DATA ACQUISITION

### DESCRIPTION

The INA141 is a low power, general purpose instrumentation amplifier offering excellent accuracy. Its versatile 3-op amp design and small size make it ideal for a wide range of applications. Current-feedback input circuitry provides wide bandwidth even at high gain (200kHz at G = 100).

Simple pin connections set an accurate gain of 10 or 100V/V without external resistors. Internal input protection can withstand up to  $\pm$ 40V without damage.

The INA141 is laser trimmed for very low offset voltage (50 $\mu$ V), drift (0.5 $\mu$ V/ $^{\circ}$ C) and high common-mode rejection (117dB at G = 100). It operates with power supplies as low as  $\pm$ 2.25V, and quiescent current is only 750 $\mu$ A—ideal for battery operated systems.

The INA141 is available in 8-pin plastic DIP, and SO-8 surface-mount packages, specified for the  $-40^{\circ}$ C to  $+85^{\circ}$ C temperature range.

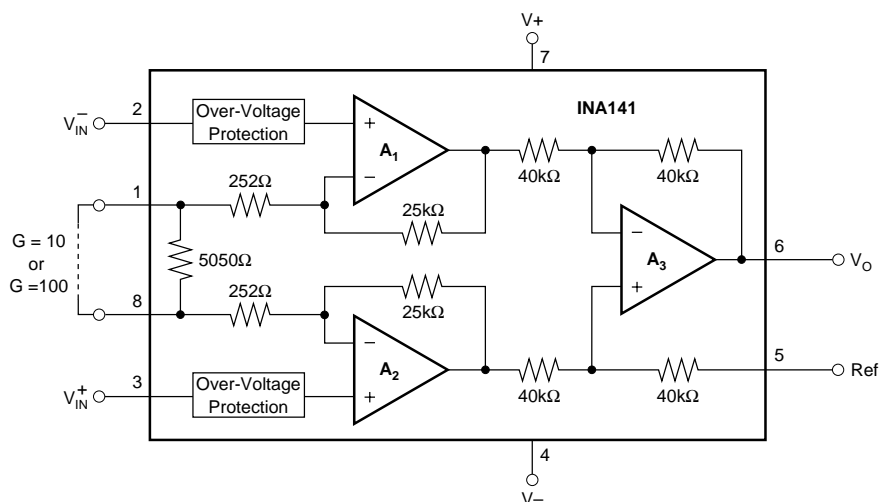

International Airport Industrial Park • Mailing Address: PO Box 11400, Tucson, AZ 85734 • Street Address: 6730 S. Tucson Blvd., Tucson, AZ 85706 • Tel: (520) 746-1111 • Twx: 910-952-1111  
Internet: <http://www.burr-brown.com/> • FAXLine: (800) 548-6133 (US/Canada Only) • Cable: BBRCORP • Telex: 066-6491 • FAX: (520) 889-1510 • Immediate Product Info: (800) 548-6132

PDS-1297B



# SPECIFICATIONS

At  $T_A = +25^\circ\text{C}$ ,  $V_S = \pm 15\text{V}$ , and  $R_L = 10\text{k}\Omega$ , unless otherwise noted.

PARAMETER	CONDITIONS	INA141P, U			INA141PA, UA			UNITS
		MIN	TYP	MAX	MIN	TYP	MAX	
<b>INPUT</b>								
Offset Voltage, RTI	$G = 100$		$\pm 20$	$\pm 50$		*	$\pm 125$	$\mu\text{V}$
	$G = 10$		$\pm 50$	$\pm 100$		*	$\pm 250$	$\mu\text{V}$
vs Temperature	$G = 100$		$\pm 0.2$	$\pm 0.5$		*	$\pm 1.5$	$\mu\text{V}/^\circ\text{C}$
	$G = 10^{(2)}$		$\pm 0.5$	$\pm 2$		*	$\pm 2.5$	$\mu\text{V}/^\circ\text{C}$
vs Power Supply	$V_S = \pm 2.25$ to $\pm 18\text{V}$ , $G = 100$		$\pm 0.4$	$\pm 1$		*	$\pm 3$	$\mu\text{V}/\text{V}$
	$G = 10$		$\pm 2$	$\pm 10$		*	$\pm 20$	$\mu\text{V}/\text{V}$
Long-Term Stability	$G = 100$		0.2			*		$\mu\text{V}/\text{mo}$
	$G = 10$		0.5			*		$\mu\text{V}/\text{mo}$
Impedance, Differential			$10^{10} \parallel 2$			*		$\Omega \parallel \text{pF}$
Common-Mode			$10^{10} \parallel 9$			*		$\Omega \parallel \text{pF}$
Common-Mode Voltage Range <sup>(1)</sup>	$V_O = 0\text{V}$	$(V+) - 2$ $(V-) + 2$	$(V+) - 1.4$ $(V-) + 1.7$		*	*		V
Safe Input Voltage				$\pm 40$			*	V
Common-Mode Rejection	$V_{CM} = \pm 13\text{V}$ , $\Delta R_S = 1\text{k}\Omega$						*	
	$G = 100$	117	125		110	120		dB
	$G = 10$	100	106		93	100		dB
<b>BIAS CURRENT</b>								
vs Temperature			$\pm 2$	$\pm 5$		*	$\pm 10$	nA
Offset Current			$\pm 30$			*		$\text{pA}/^\circ\text{C}$
vs Temperature			$\pm 1$	$\pm 5$		*	$\pm 10$	nA
			$\pm 30$			*		$\text{pA}/^\circ\text{C}$
<b>NOISE VOLTAGE, RTI</b>								
$f = 10\text{Hz}$	$G = 100$ , $R_S = 0\Omega$		10			*		$\text{nV}/\sqrt{\text{Hz}}$
$f = 100\text{Hz}$			8			*		$\text{nV}/\sqrt{\text{Hz}}$
$f = 1\text{kHz}$			8			*		$\text{nV}/\sqrt{\text{Hz}}$
$f_B = 0.1\text{Hz}$ to $10\text{Hz}$			0.2			*		$\mu\text{Vp-p}$
$f = 10\text{Hz}$	$G = 10$ , $R_S = 0\Omega$		22			*		$\text{nV}/\sqrt{\text{Hz}}$
$f = 100\text{Hz}$			13			*		$\text{nV}/\sqrt{\text{Hz}}$
$f = 1\text{kHz}$			12			*		$\text{nV}/\sqrt{\text{Hz}}$
$f_B = 0.1\text{Hz}$ to $10\text{Hz}$			0.6			*		$\mu\text{Vp-p}$
Noise Current								
$f = 10\text{Hz}$			0.9			*		$\text{pA}/\sqrt{\text{Hz}}$
$f = 1\text{kHz}$			0.3			*		$\text{pA}/\sqrt{\text{Hz}}$
$f_B = 0.1\text{Hz}$ to $10\text{Hz}$			30			*		$\text{pAp-p}$
<b>GAIN</b>								
Gain Error	$V_O = \pm 13.6\text{V}$ , $G = 100$		$\pm 0.03$	$\pm 0.075$		*	$\pm 0.15$	%
	$G = 10$		$\pm 0.01$	$\pm 0.05$		*	$\pm 0.15$	%
Gain vs Temperature <sup>(2)</sup>	$G = 10, 100$		$\pm 2$	$\pm 10$		*	*	$\text{ppm}/^\circ\text{C}$
Nonlinearity	$G = 100$		$\pm 0.0005$	$\pm 0.002$		*	$\pm 0.004$	% of FSR
	$G = 10$		$\pm 0.0003$	$\pm 0.001$		*	$\pm 0.002$	% of FSR
<b>OUTPUT</b>								
Voltage: Positive	$R_L = 10\text{k}\Omega$	$(V+) - 1.4$	$(V+) - 0.9$		*	*		V
Negative	$R_L = 10\text{k}\Omega$	$(V-) + 1.4$	$(V-) + 0.9$		*	*		V
Load Capacitance Stability			1000			*		pF
Short-Circuit Current			+6/-15			*		mA
<b>FREQUENCY RESPONSE</b>								
Bandwidth, -3dB	$G = 100$		200			*		kHz
	$G = 10$		1			*		MHz
Slew Rate	$V_O = \pm 10\text{V}$ , $G = 10$		4			*		V/ $\mu\text{s}$
Settling Time, 0.01%	$V_O = \pm 5\text{V}$ , $G = 100$		9			*		$\mu\text{s}$
	$G = 10$		7			*		$\mu\text{s}$
Overload Recovery	50% Overdrive		4			*		$\mu\text{s}$
<b>POWER SUPPLY</b>								
Voltage Range		$\pm 2.25$	$\pm 15$	$\pm 18$	*	*	*	V
Current, Total	$V_{IN} = 0\text{V}$		$\pm 750$	$\pm 800$		*	*	$\mu\text{A}$
<b>TEMPERATURE RANGE</b>								
Specification		-40		85	*		*	$^\circ\text{C}$
Operating		-40		125	*		*	$^\circ\text{C}$
$\theta_{JA}$ 8-Pin DIP			80			*		$^\circ\text{C}/\text{W}$
SO-8 SOIC			150			*		$^\circ\text{C}/\text{W}$

\* Specification same as INA141P, U.

NOTE: (1) Input common-mode range varies with output voltage—see typical curves. (2) Guaranteed by wafer test.

The information provided herein is believed to be reliable; however, BURR-BROWN assumes no responsibility for inaccuracies or omissions. BURR-BROWN assumes no responsibility for the use of this information, and all use of such information shall be entirely at the user's own risk. Prices and specifications are subject to change without notice. No patent rights or licenses to any of the circuits described herein are implied or granted to any third party. BURR-BROWN does not authorize or warrant any BURR-BROWN product for use in life support devices and/or systems.

## PIN CONFIGURATION

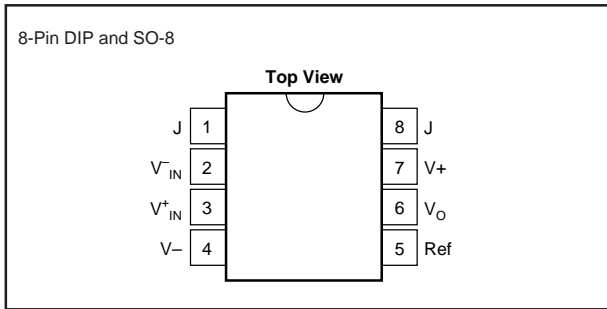

## ABSOLUTE MAXIMUM RATINGS

Supply Voltage .....	±18V
Analog Input Voltage Range .....	±40V
Output Short-Circuit (to ground) .....	Continuous
Operating Temperature .....	-40°C to +125°C
Storage Temperature .....	-40°C to +125°C
Junction Temperature .....	+150°C
Lead Temperature (soldering, 10s) .....	+300°C

## ELECTROSTATIC DISCHARGE SENSITIVITY

This integrated circuit can be damaged by ESD. Burr-Brown recommends that all integrated circuits be handled with appropriate precautions. Failure to observe proper handling and installation procedures can cause damage.

ESD damage can range from subtle performance degradation to complete device failure. Precision integrated circuits may be more susceptible to damage because very small parametric changes could cause the device not to meet its published specifications.

## ORDERING INFORMATION

PRODUCT	PACKAGE	PACKAGE DRAWING NUMBER <sup>(1)</sup>	TEMPERATURE RANGE
INA141PA	8-Pin Plastic DIP	006	-40°C to +85°C
INA141P	8-Pin Plastic DIP	006	-40°C to +85°C
INA141UA	SO-8 Surface-Mount	182	-40°C to +85°C
INA141U	SO-8 Surface-Mount	182	-40°C to +85°C

NOTE: (1) For detailed drawing and dimension table, please see end of data sheet, or Appendix C of Burr-Brown IC Data Book.

# TYPICAL PERFORMANCE CURVES

At  $T_A = +25^\circ\text{C}$  and  $V_S = \pm 15\text{V}$ , unless otherwise noted.

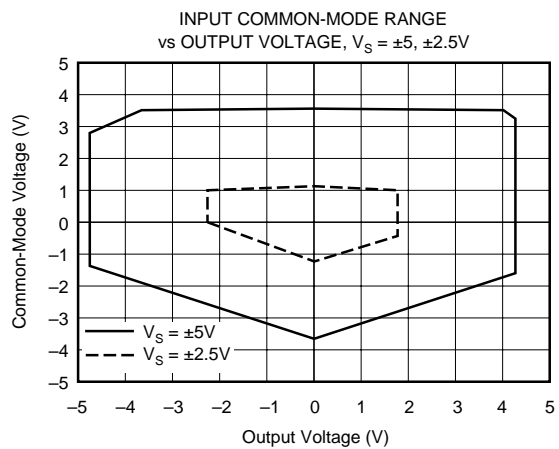
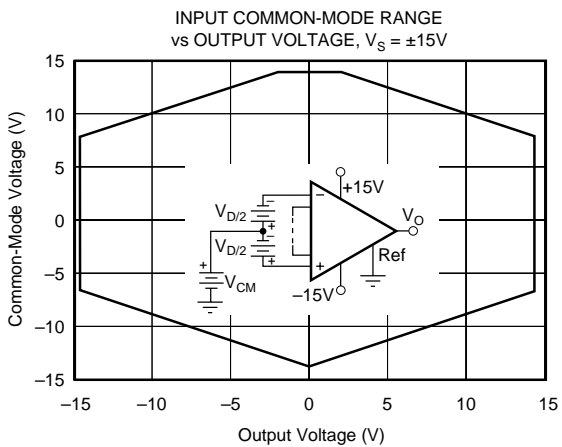
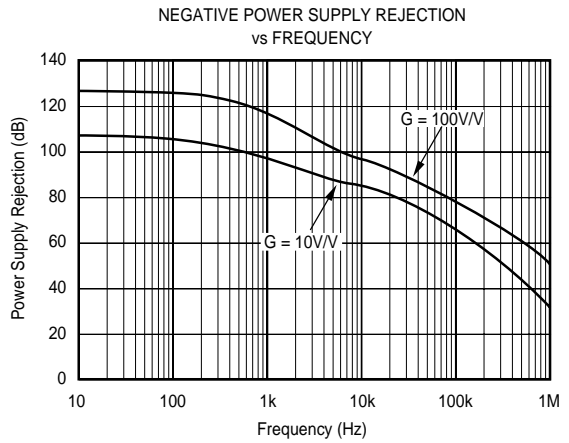
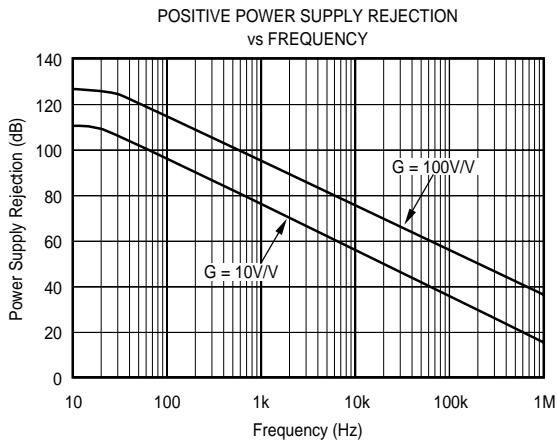
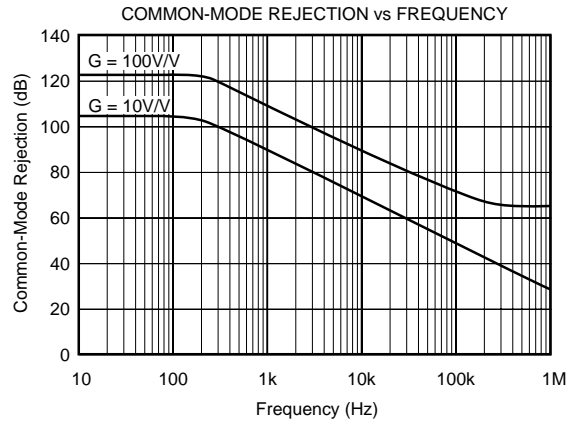
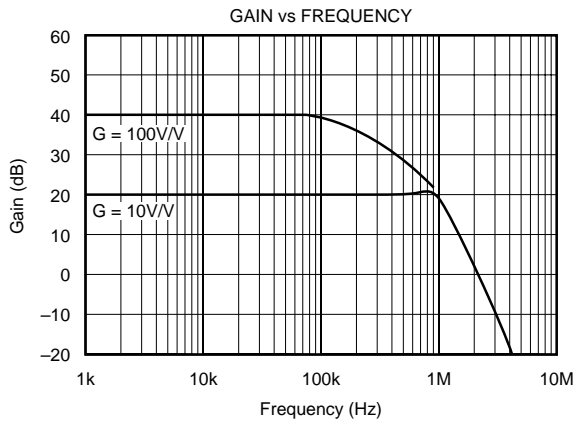

# TYPICAL PERFORMANCE CURVES (CONT)

At  $T_A = +25^\circ\text{C}$  and  $V_S = \pm 15\text{V}$ , unless otherwise noted.

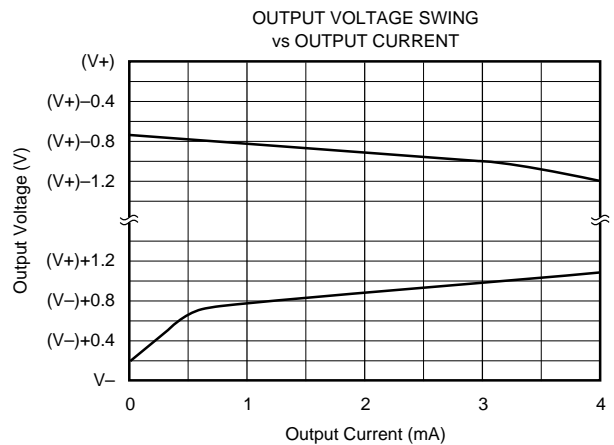
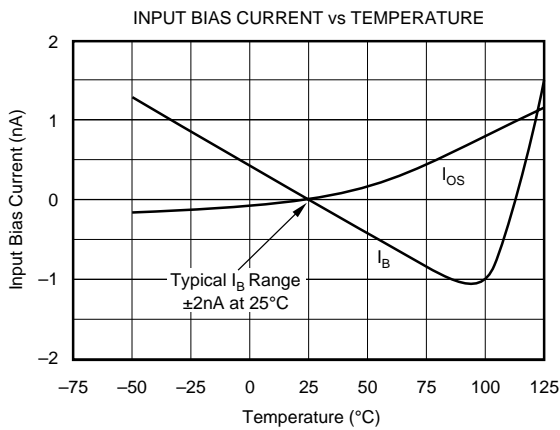
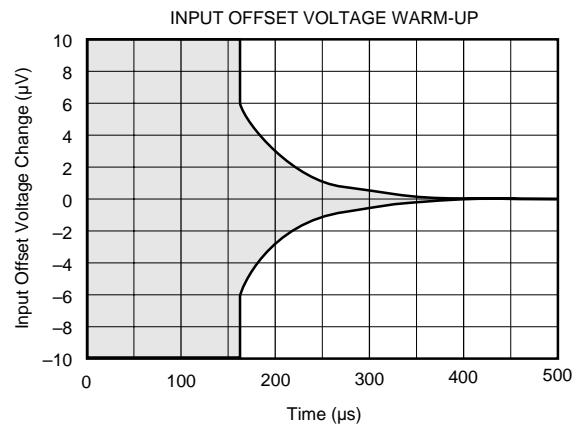
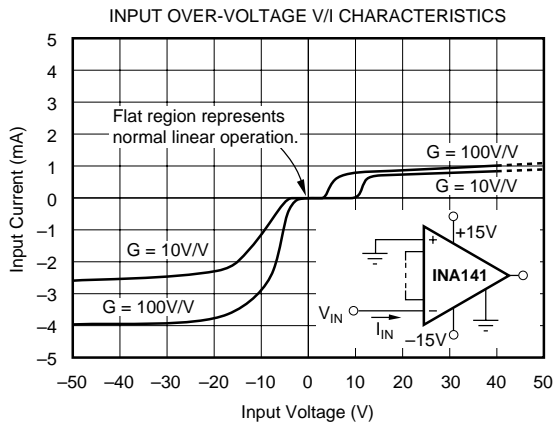
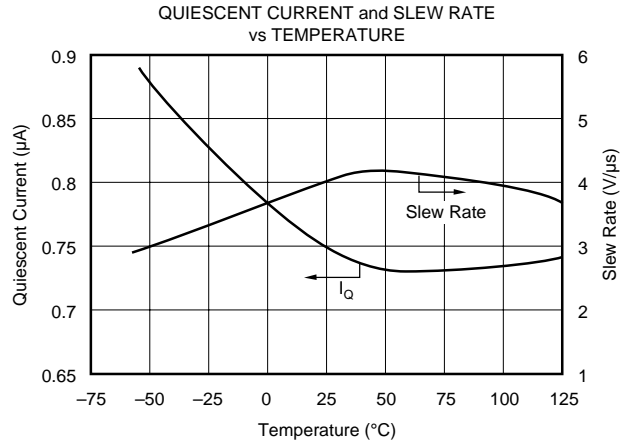
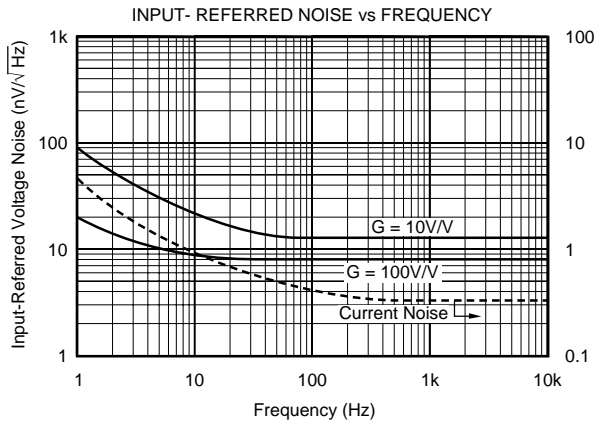

# TYPICAL PERFORMANCE CURVES (CONT)

At  $T_A = +25^\circ\text{C}$  and  $V_S = \pm 15\text{V}$ , unless otherwise noted.

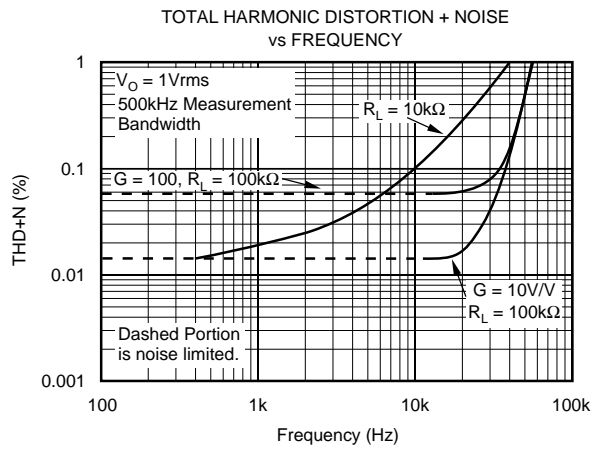
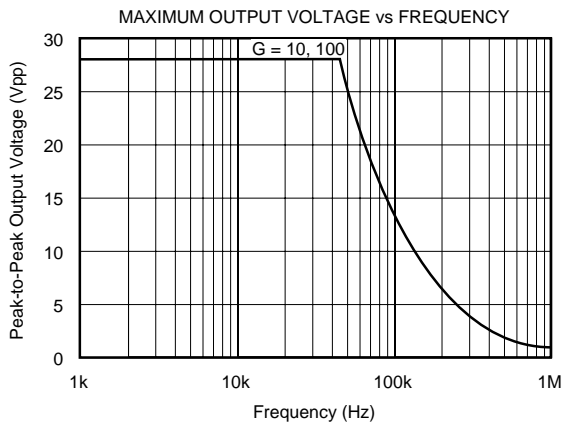
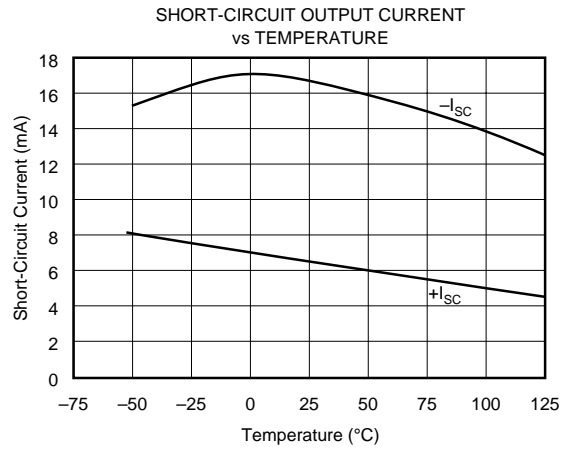
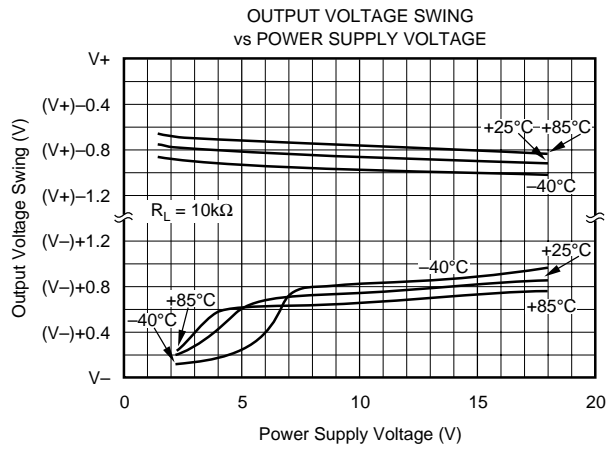

# TYPICAL PERFORMANCE CURVES (CONT)

At  $T_A = +25^\circ\text{C}$  and  $V_S = \pm 15\text{V}$ , unless otherwise noted.

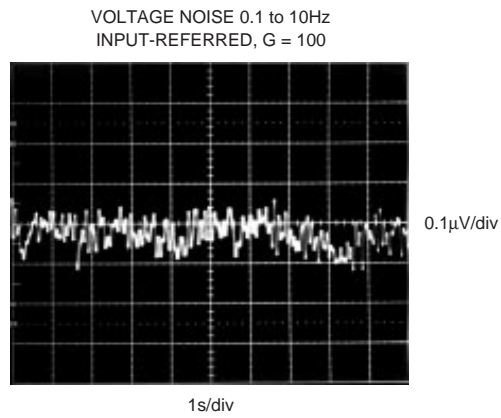
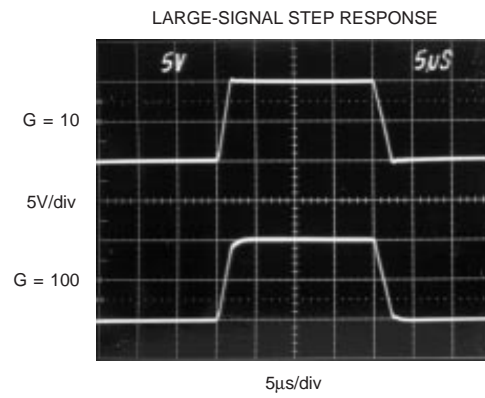
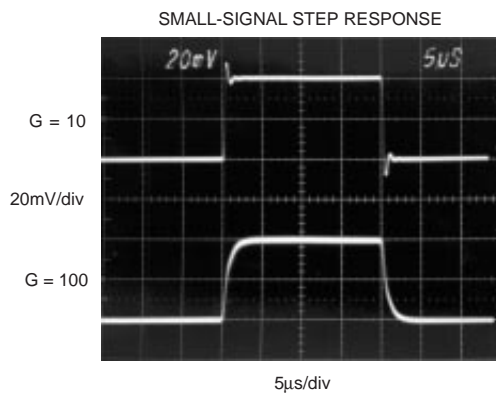

# APPLICATION INFORMATION

Figure 1 shows the basic connections required for operation of the INA141. Applications with noisy or high impedance power supplies may require decoupling capacitors close to the device pins as shown.

The output is referred to the output reference (Ref) terminal which is normally grounded. This must be a low-impedance connection to assure good common-mode rejection. A resistance of  $8\Omega$  in series with the Ref pin will cause a typical device to degrade to approximately 80dB CMR ( $G = 1$ ).

## SETTING THE GAIN

Gain is selected with a jumper connection as shown in Figure 1.  $G = 10V/V$  with no jumper installed. With a jumper installed,  $G = 100V/V$ . To preserve good gain accuracy, this jumper must have low series resistance. A resistance of  $0.5\Omega$  in series with the jumper will decrease the gain by 0.1%.

Internal resistor ratios are laser trimmed to assure excellent gain accuracy. Actual resistor values can vary by approximately  $\pm 25\%$  from the nominal values shown.

Gains between 10 and 100 can be achieved by connecting an external resistor to the jumper pins. This is not recommended, however, because the  $\pm 25\%$  variation of internal resistor values makes the required external resistor value uncertain. A companion model, INA128, features accurately trimmed internal resistors so that gains from 1 to 10,000 can be set with an external resistor.

## DYNAMIC PERFORMANCE

The typical performance curve "Gain vs Frequency" shows that, despite its low quiescent current, the INA141 achieves wide bandwidth, even at  $G = 100$ . This is due to the current-feedback topology of the INA141. Settling time also remains excellent at  $G = 100$ .

## NOISE PERFORMANCE

The INA141 provides very low noise in most applications. Low frequency noise is approximately  $0.2\mu V_p-p$  measured from 0.1 to 10Hz ( $G = 100$ ). This provides dramatically improved noise when compared to state-of-the-art chopper-stabilized amplifiers.

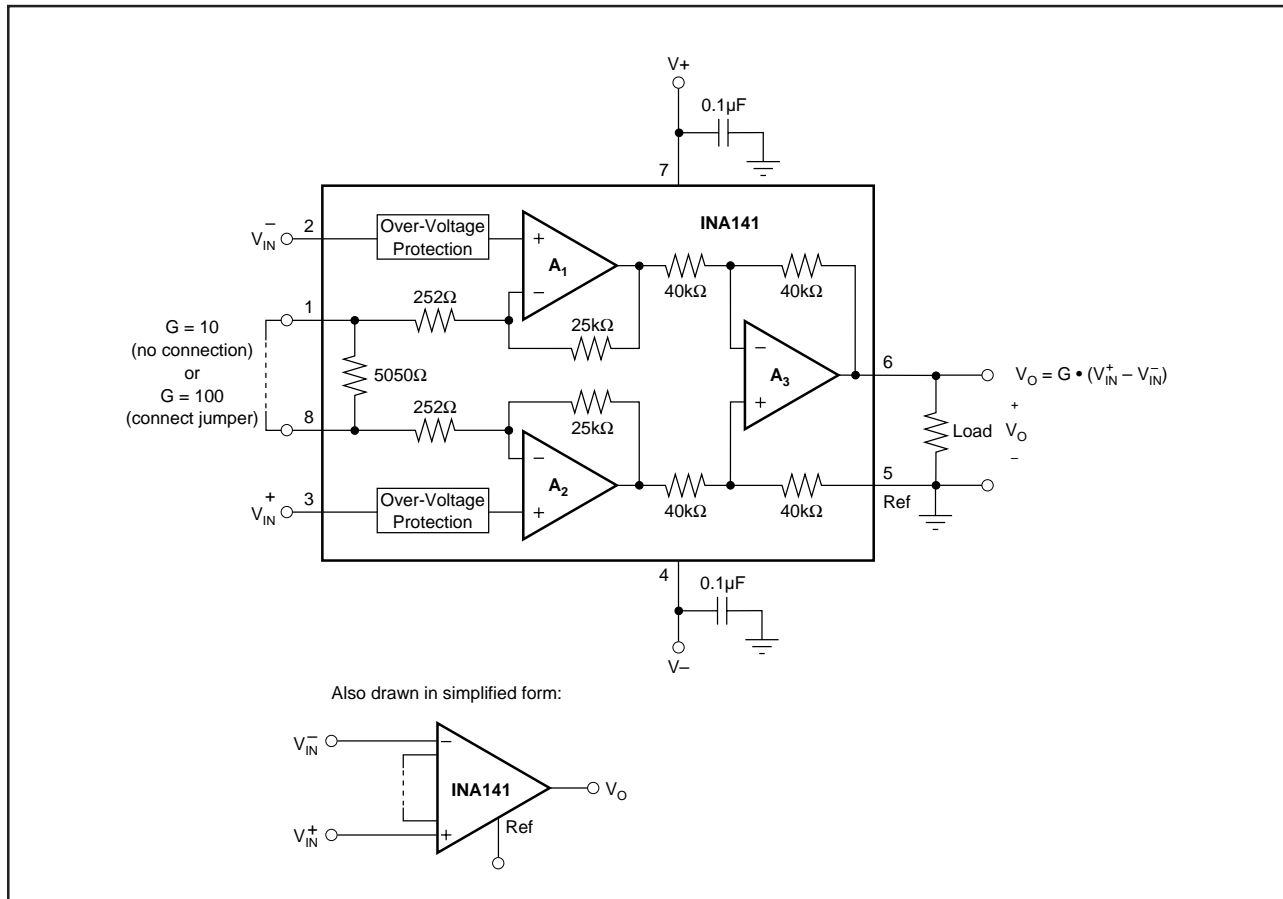

FIGURE 1. Basic Connections.



## OFFSET TRIMMING

The INA141 is laser trimmed for low offset voltage and offset voltage drift. Most applications require no external offset adjustment. Figure 2 shows an optional circuit for trimming the output offset voltage. The voltage applied to Ref terminal is summed with the output. The op amp buffer provides low impedance at the Ref terminal to preserve good common-mode rejection.

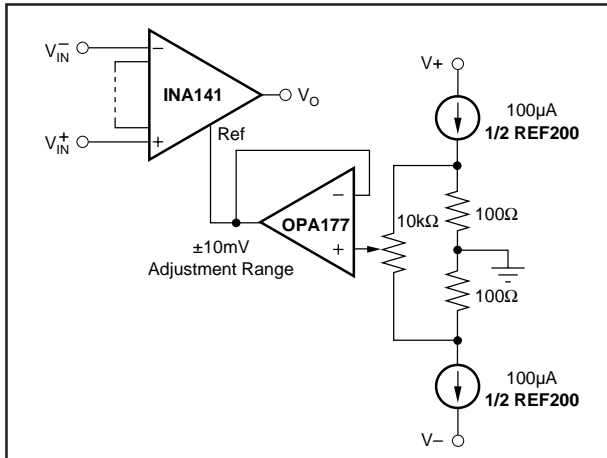

FIGURE 2. Optional Trimming of Output Offset Voltage.

## INPUT BIAS CURRENT RETURN PATH

The input impedance of the INA141 is extremely high—approximately  $10^{10}\Omega$ . However, a path must be provided for the input bias current of both inputs. This input bias current is approximately  $\pm 2\text{nA}$ . High input impedance means that this input bias current changes very little with varying input voltage.

Input circuitry must provide a path for this input bias current for proper operation. Figure 3 shows various provisions for an input bias current path. Without a bias current path, the inputs will float to a potential which exceeds the common-mode range of the INA141 and the input amplifiers will saturate.

If the differential source resistance is low, the bias current return path can be connected to one input (see the thermocouple example in Figure 3). With higher source impedance, using two equal resistors provides a balanced input with possible advantages of lower input offset voltage due to bias current and better high-frequency common-mode rejection.

## INPUT COMMON-MODE RANGE

The linear input voltage range of the input circuitry of the INA141 is from approximately 1.4V below the positive supply voltage to 1.7V above the negative supply. As a differential input voltage causes the output voltage to increase, however, the linear input range will be limited by the output voltage swing of amplifiers  $A_1$  and  $A_2$ . So the linear common-mode input range is related to the output voltage of the complete amplifier. This behavior also depends on supply voltage—see performance curves “Input Common-Mode Range vs Output Voltage”.

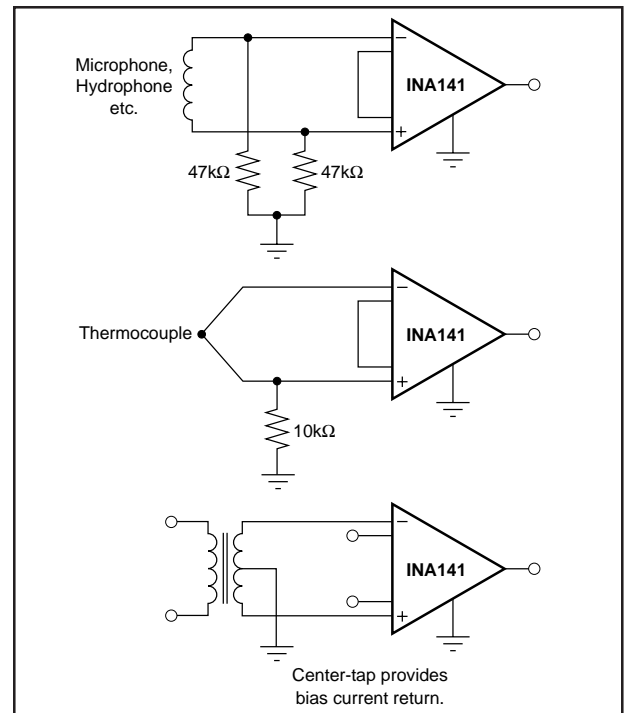

FIGURE 3. Providing an Input Common-Mode Current Path.

Input overload can produce an output voltage that appears normal. For example, if an input overload condition drives both input amplifiers to their positive output swing limit, the difference voltage measured by the output amplifier will be near zero. The output of the INA141 will be near 0V even though both inputs are overloaded.

## LOW VOLTAGE OPERATION

The INA141 can be operated on power supplies as low as  $\pm 2.25\text{V}$ . Performance remains excellent with power supplies ranging from  $\pm 2.25\text{V}$  to  $\pm 18\text{V}$ . Most parameters vary only slightly through this supply voltage range—see Typical Performance Curves. Operation at very low supply voltage requires careful attention to assure that the input voltages remain within their linear range. Voltage swing requirements of internal nodes limit the input common-mode range with low power supply voltage. Typical performance curves, “Input Common-Mode Range vs Output Voltage” show the range of linear operation for  $\pm 15\text{V}$ ,  $\pm 5$ , and  $\pm 2.5\text{V}$  supplies.

## INPUT PROTECTION

The inputs of the INA141 are individually protected for voltages up to  $\pm 40\text{V}$ . For example, a condition of  $-40\text{V}$  on one input and  $+40\text{V}$  on the other input will not cause damage. Internal circuitry on each input provides low series impedance under normal signal conditions. To provide equivalent protection, series input resistors would contribute excessive noise. If the input is overloaded, the protection circuitry limits the input current to a safe value of approximately 1.5 to 5mA. The typical performance curve “Input Bias Current vs Common-Mode Input Voltage” shows this input current limit behavior. The inputs are protected even if the power supplies are disconnected or turned off.

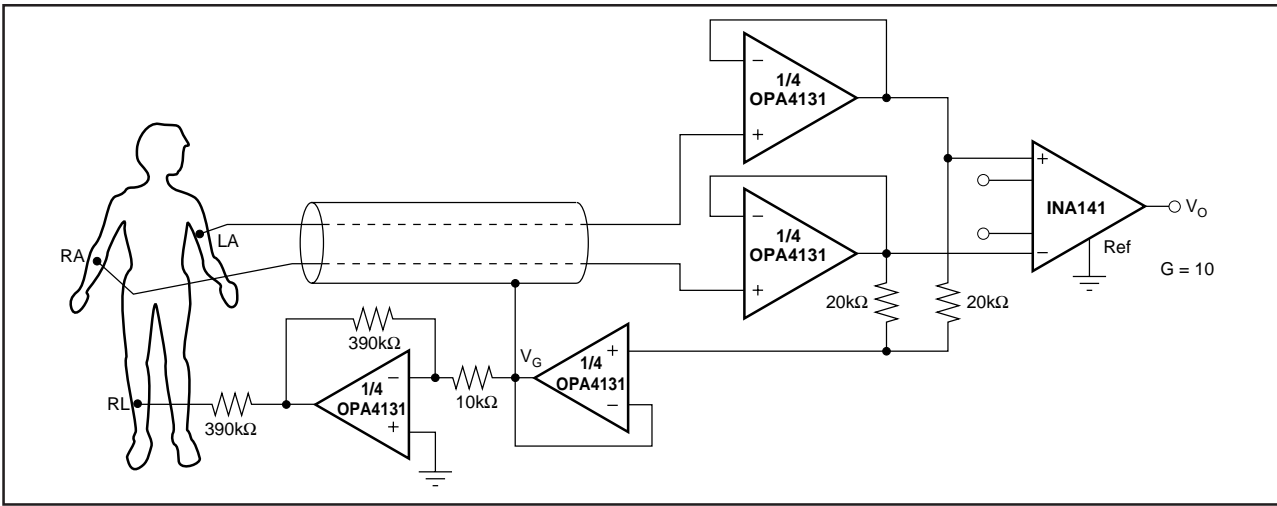

FIGURE 4. ECG Amplifier With Right-Leg Drive.

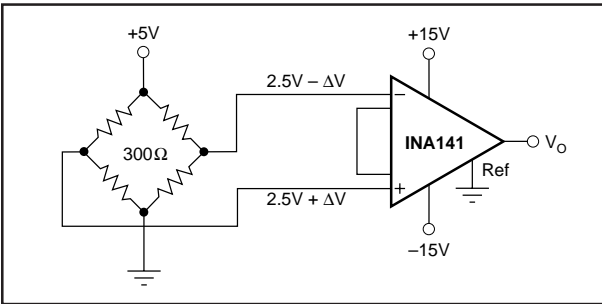

FIGURE 5. Bridge Amplifier.

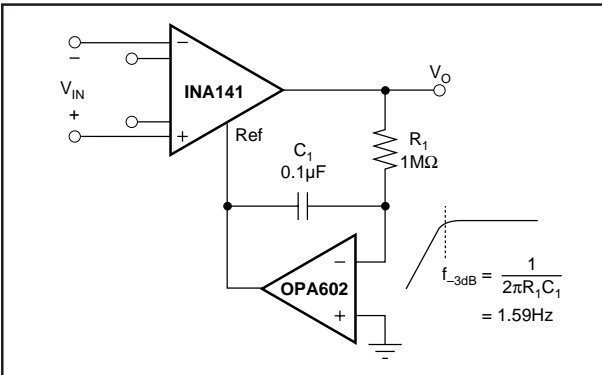

FIGURE 6. AC-Coupled Instrumentation Amplifier.

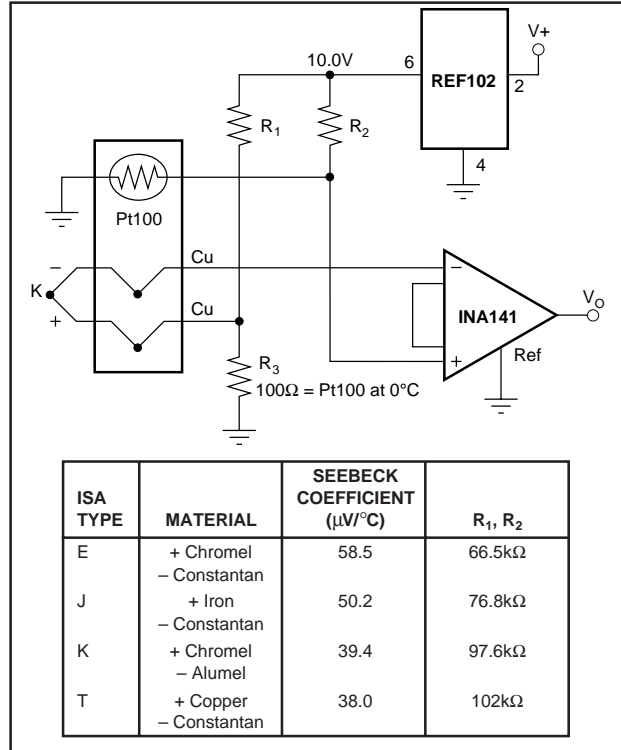

FIGURE 7. Thermocouple Amplifier With RTD Cold-Junction Compensation.

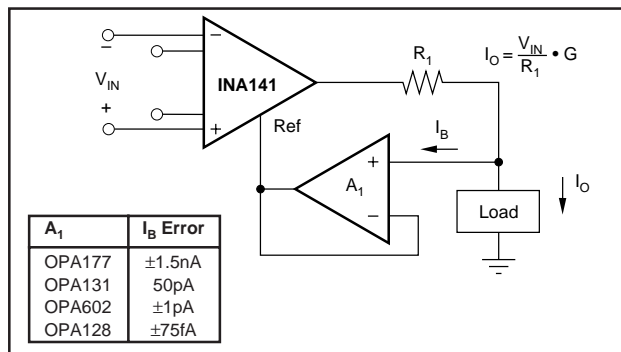

FIGURE 8. Differential Voltage to Current Converter.

**PACKAGING INFORMATION**

Orderable Device	Status (1)	Package Type	Package Drawing	Pins	Package Qty	Eco Plan (2)	Lead finish/ Ball material (6)	MSL Peak Temp (3)	Op Temp (°C)	Device Marking (4/5)	Samples
INA141U	ACTIVE	SOIC	D	8	75	RoHS & Green	NIPDAU	Level-3-260C-168 HR		INA 141U	<a href="#">Samples</a>
INA141U/2K5	ACTIVE	SOIC	D	8	2500	RoHS & Green	NIPDAU	Level-3-260C-168 HR		INA 141U	<a href="#">Samples</a>
INA141U/2K5E4	ACTIVE	SOIC	D	8	2500	RoHS & Green	NIPDAU	Level-3-260C-168 HR		INA 141U	<a href="#">Samples</a>
INA141UA	ACTIVE	SOIC	D	8	75	RoHS & Green	NIPDAU	Level-3-260C-168 HR	-40 to 85	INA 141U A	<a href="#">Samples</a>
INA141UA/2K5	ACTIVE	SOIC	D	8	2500	RoHS & Green	NIPDAU	Level-3-260C-168 HR	-40 to 85	INA 141U A	<a href="#">Samples</a>
INA141UA/2K5E4	ACTIVE	SOIC	D	8	2500	RoHS & Green	NIPDAU	Level-3-260C-168 HR	-40 to 85	INA 141U A	<a href="#">Samples</a>
INA141UAE4	ACTIVE	SOIC	D	8	75	RoHS & Green	NIPDAU	Level-3-260C-168 HR	-40 to 85	INA 141U A	<a href="#">Samples</a>

(1) The marketing status values are defined as follows:

**ACTIVE:** Product device recommended for new designs.

**LIFEBUY:** TI has announced that the device will be discontinued, and a lifetime-buy period is in effect.

**NRND:** Not recommended for new designs. Device is in production to support existing customers, but TI does not recommend using this part in a new design.

**PREVIEW:** Device has been announced but is not in production. Samples may or may not be available.

**OBSOLETE:** TI has discontinued the production of the device.

(2) **RoHS:** TI defines "RoHS" to mean semiconductor products that are compliant with the current EU RoHS requirements for all 10 RoHS substances, including the requirement that RoHS substance do not exceed 0.1% by weight in homogeneous materials. Where designed to be soldered at high temperatures, "RoHS" products are suitable for use in specified lead-free processes. TI may reference these types of products as "Pb-Free".

**RoHS Exempt:** TI defines "RoHS Exempt" to mean products that contain lead but are compliant with EU RoHS pursuant to a specific EU RoHS exemption.

**Green:** TI defines "Green" to mean the content of Chlorine (Cl) and Bromine (Br) based flame retardants meet JS709B low halogen requirements of <=1000ppm threshold. Antimony trioxide based flame retardants must also meet the <=1000ppm threshold requirement.

(3) MSL, Peak Temp. - The Moisture Sensitivity Level rating according to the JEDEC industry standard classifications, and peak solder temperature.

(4) There may be additional marking, which relates to the logo, the lot trace code information, or the environmental category on the device.

(5) Multiple Device Markings will be inside parentheses. Only one Device Marking contained in parentheses and separated by a "~" will appear on a device. If a line is indented then it is a continuation of the previous line and the two combined represent the entire Device Marking for that device.

(6) Lead finish/Ball material - Orderable Devices may have multiple material finish options. Finish options are separated by a vertical ruled line. Lead finish/Ball material values may wrap to two lines if the finish value exceeds the maximum column width.

**Important Information and Disclaimer:**The information provided on this page represents TI's knowledge and belief as of the date that it is provided. TI bases its knowledge and belief on information provided by third parties, and makes no representation or warranty as to the accuracy of such information. Efforts are underway to better integrate information from third parties. TI has taken and continues to take reasonable steps to provide representative and accurate information but may not have conducted destructive testing or chemical analysis on incoming materials and chemicals. TI and TI suppliers consider certain information to be proprietary, and thus CAS numbers and other limited information may not be available for release.

In no event shall TI's liability arising out of such information exceed the total purchase price of the TI part(s) at issue in this document sold by TI to Customer on an annual basis.

## TAPE AND REEL INFORMATION



### QUADRANT ASSIGNMENTS FOR PIN 1 ORIENTATION IN TAPE



\*All dimensions are nominal

Device	Package Type	Package Drawing	Pins	SPQ	Reel Diameter (mm)	Reel Width W1 (mm)	A0 (mm)	B0 (mm)	K0 (mm)	P1 (mm)	W (mm)	Pin1 Quadrant
INA141U/2K5	SOIC	D	8	2500	330.0	12.4	6.4	5.2	2.1	8.0	12.0	Q1
INA141UA/2K5	SOIC	D	8	2500	330.0	12.4	6.4	5.2	2.1	8.0	12.0	Q1

**TAPE AND REEL BOX DIMENSIONS**

\*All dimensions are nominal

Device	Package Type	Package Drawing	Pins	SPQ	Length (mm)	Width (mm)	Height (mm)
INA141U/2K5	SOIC	D	8	2500	367.0	367.0	35.0
INA141UA/2K5	SOIC	D	8	2500	853.0	449.0	35.0

## IMPORTANT NOTICE AND DISCLAIMER

TI PROVIDES TECHNICAL AND RELIABILITY DATA (INCLUDING DATASHEETS), DESIGN RESOURCES (INCLUDING REFERENCE DESIGNS), APPLICATION OR OTHER DESIGN ADVICE, WEB TOOLS, SAFETY INFORMATION, AND OTHER RESOURCES "AS IS" AND WITH ALL FAULTS, AND DISCLAIMS ALL WARRANTIES, EXPRESS AND IMPLIED, INCLUDING WITHOUT LIMITATION ANY IMPLIED WARRANTIES OF MERCHANTABILITY, FITNESS FOR A PARTICULAR PURPOSE OR NON-INFRINGEMENT OF THIRD PARTY INTELLECTUAL PROPERTY RIGHTS.

These resources are intended for skilled developers designing with TI products. You are solely responsible for (1) selecting the appropriate TI products for your application, (2) designing, validating and testing your application, and (3) ensuring your application meets applicable standards, and any other safety, security, or other requirements. These resources are subject to change without notice. TI grants you permission to use these resources only for development of an application that uses the TI products described in the resource. Other reproduction and display of these resources is prohibited. No license is granted to any other TI intellectual property right or to any third party intellectual property right. TI disclaims responsibility for, and you will fully indemnify TI and its representatives against, any claims, damages, costs, losses, and liabilities arising out of your use of these resources.

TI's products are provided subject to TI's Terms of Sale (<https://www.ti.com/legal/termsofsale.html>) or other applicable terms available either on [ti.com](https://www.ti.com) or provided in conjunction with such TI products. TI's provision of these resources does not expand or otherwise alter TI's applicable warranties or warranty disclaimers for TI products.

Mailing Address: Texas Instruments, Post Office Box 655303, Dallas, Texas 75265  
Copyright © 2021, Texas Instruments Incorporated