

CLW-1809-W2E-ER series

9V / 2A Wall mounted type AC/DC adaptor



■ Features:

- Universal AC input / Full range
- ErP step II / CEC level VI compliance
- No load power consumption $P < 0.075W$
- Protections: Overload / Short circuit / Over Voltage



ELECTRICAL SPECIFICATION

MODEL	CLW-1809-W2E-ER
-------	-----------------

OUTPUT

Rated Voltage	9V
Rated Current	2A
Current Range	0 ÷ 2A
Rated Power	18W
Line Regulation	± 1%
Load Regulation	± 5%
Tolerance [3]	± 8%
Ripple & Noise (max.) [2]	200mV _{p-p}
Setup, Rise Time [4]	5000ms, 30ms / 230VAC at full load
Hold up Time (typ.)	4ms / 230VAC at full load

INPUT

Voltage Range	90 ÷ 264VAC
Frequency Range	47 ÷ 63Hz
Efficiency (typ.)	81.66%
AC Current (typ.)	0.4A / 115VAC, 0.2A / 230VAC
No load Power Consumption (max.)	0.075W

PROTECTIONS

Overload	Range: 105-200% Auto-recovery.
Short Circuit	Type: hiccup mode, auto-recovery.
Over Voltage	Type: auto-recovery.

CLW-1809-W2E-ER series

9V / 2A Wall mounted type AC/DC adaptor



WORKING ENVIRONMENT

Working Temperature	0°C ÷ 40°C
Working Humidity	10 ÷ 90% RH non-condensing
Storage Temperature and Humidity	-20° C ÷ 85° C, 5 ÷ 90% RH non-condensing

SAFETY and EMC REGULATIONS

Safety Standards	Compliance to EN 62368
Withstand Voltage	IN/OUT: 3.6kVAC
Isolation Resistance	IN/OUT: 50M Ω /500VDC/25° C/70%
EMC Emission	Compliance to EN55032
EMC Immunity	Compliance to EN61000-4-2, -3, -4, -5
Harmonic Current	Compliance to EN61000-3-3; EN61000-3-2

OTHERS

DC wire and plug	Wire: 22AWG*2C, length = 1500mm	Plug: 2.1/5.5, positive inside
Dimensions	78.7 x 27.6 x 69.1mm (L x W x H)	
Net Weight	90.1g	

1. All parameters NOT specially mentioned are measured at 230VAC input, rated load and 25° C of ambient temperature.
2. Ripple & noise are measured at 20MHz of bandwidth by using a 12" twisted pair-wire terminated with a 0.1 μ F i 47 μ F parallel capacitor.
3. Tolerance includes set up tolerance, line regulation and load regulation.
4. Setup and rise time is measured from 0 to 90% rated output voltage.
5. Power supply is considered as component not indented to apply by end-user. Power supply meets safety and EMC standards however the final equipment with power supply must be re-quality to comply with EMC Directives.

MECHANICAL SPECIFICATION

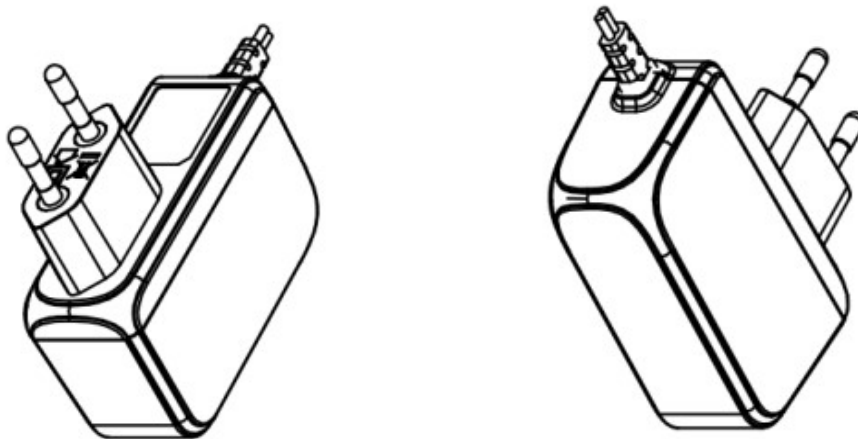

CLW-1809-W2E-ER series

9V / 2A Wall mounted type AC/DC adaptor



MECHANICAL SPECIFICATION

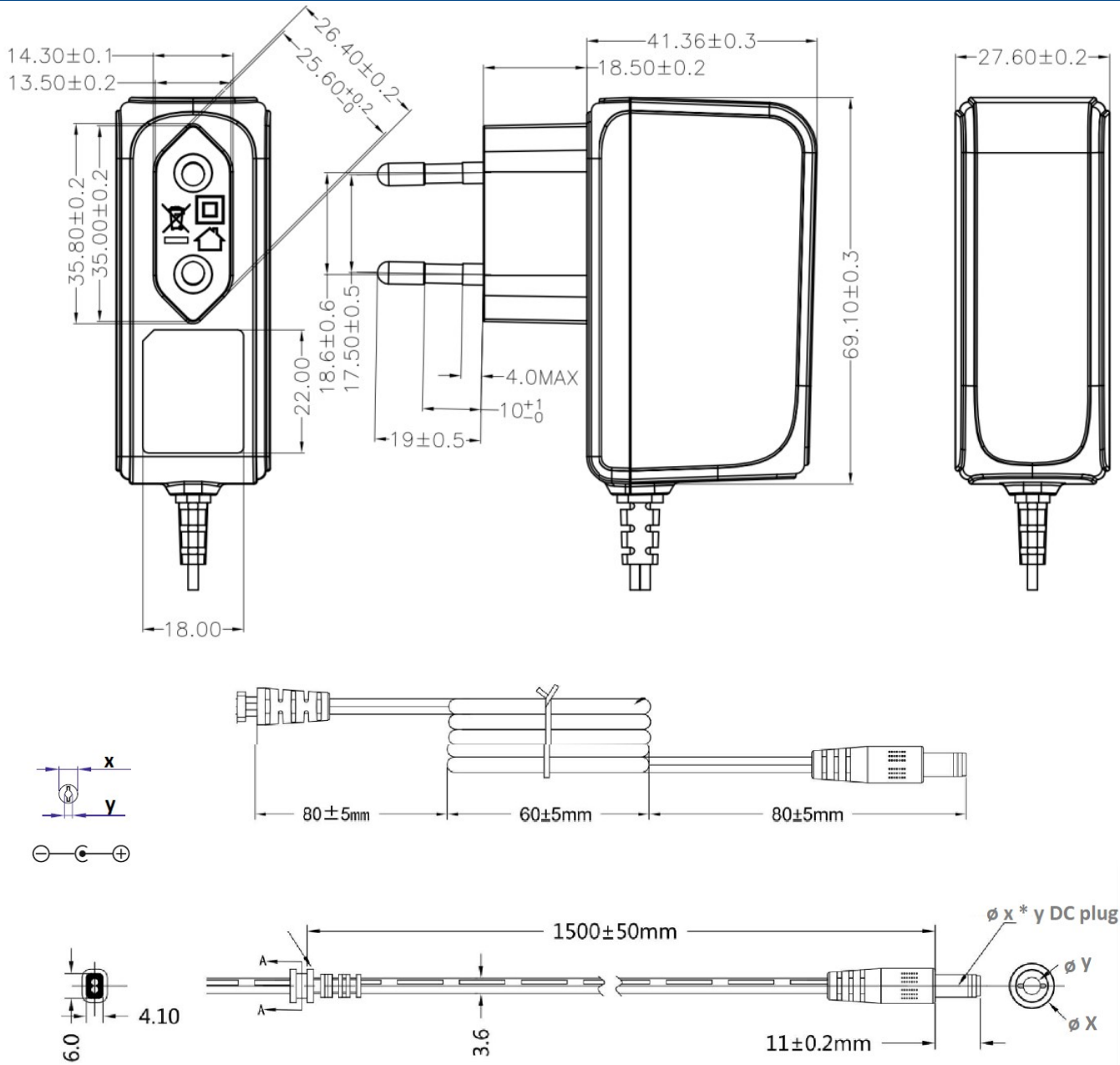

*MODEL	DC PLUG	X [mm]	Y [mm]	Polarity
CLW-1809-W2E-ER	5.5x2.1mm	5.5	2.1	center positive
CLW-1809-W2E-ER25	5.5x2.5mm	5.5	2.5	center positive
CLW-1809-W2E-ER13	3.5x1.3mm	3.5	1.3	center positive
CLW-1809-W2E-ER40	4.0x1.7mm	4.0	1.7	center positive
CLW-1809-W2E-ER48	4.8x1.7mm	4.8	1.7	center positive
CLW-1809-W2E-ER-CN	5.5x2.1mm	5.5	2.1	center negative
CLW-1809-W2E-ER25-CN	5.5x2.5mm	5.5	2.5	center negative
CLW-1809-W2E-ER13-CN	3.5x1.3mm	3.5	1.3	center negative
CLW-1809-W2E-ER40-CN	4.0x1.7mm	4.0	1.7	center negative
CLW-1809-W2E-ER48-CN	4.8x1.7mm	4.8	1.7	center negative

CLW-1809-W2E-ER series

9V / 2A Wall mounted type AC/DC adaptor

