

Enclosures can be Factory Modified ( Milling, Drilling, Printing etc.)  
 Contact Factory [mjm@hammondmfg.com](mailto:mjm@hammondmfg.com) for quotes  
 Solid models of this enclosure available in STEP or IGES.  
 (Part number and text placement/orientation on our products are subject to change,  
 we do not recommend using them as a locating reference for modification purposes)

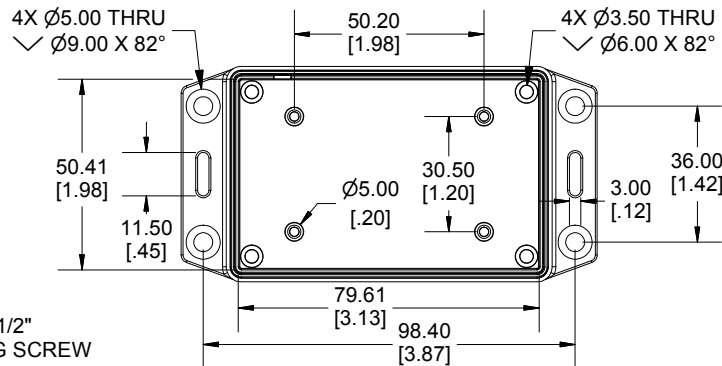
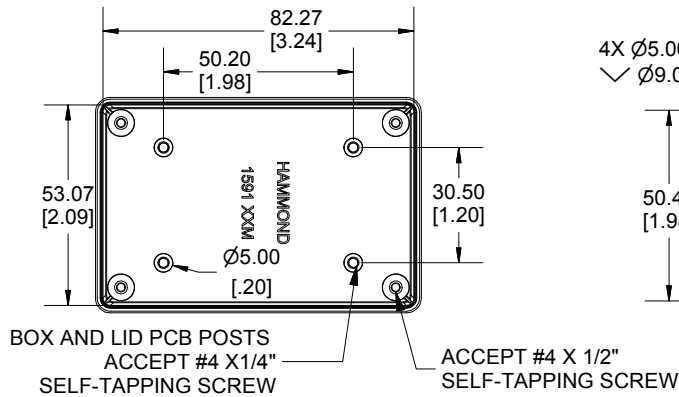

NOTE	
Tab dimensions show maximum size, tab may vary.	
Purchased assembly includes box, lid and 4 cover screws.	
Enclosure molded from GPABS Plastic.	
Other materials / colours available consult factory.	
Recommended Torque : (35-43) Ozf.in / (25-30) cN.m	

PART NUMBERS	
1591XXMSFL Enclosure	
Black Textured Enclosure	1591XXMSFLBK
ACCESSORIES	
Black Cover Screws #4 X 1/2" Self-tapping	1591TS100BK (Pkg 100)
Plated Cover Screws #4 X 1/2" Self-tapping	1591TS100 (Pkg 100)
Plated Cover Screws [M3-0.5 X 10mm]P.C.	1593ATS50 (Pkg 50)
Board Screws	1593ATS100 (Pkg 100)

**HAMMOND  
MANUFACTURING®**

**1591XXMSFL**

[www.hammondmfg.com](http://www.hammondmfg.com)

Dimensions:  
mm  
[inches]