



Beta CW Datasheet

Beta CW

The Beta CW from Global Laser is a robust, high quality laser diode module which provides a reliable laser source to a wide range of applications including alignment, edge detection and bar code reading.

A wide range of standard wavelength and powers are available for the Beta CW which also features the benefits of an isolated housing and reverse polarity protection as standard. An A/R coated user adjustable collimating lens produces an elliptical output beam which can be focused to produce a fine focused spot. Lens assemblies which circularize the beam or provide lower beam divergence can also be supplied. A variety of line generating optics are also available. Some models also feature a TTL input to allow the output to be pulsed on and off via a TTL level signal.

A wide range of mounting clamps are also available which allows the user to mount the Beta CW securely to a machine or workbench while still allowing parallel and vertical adjustment.



Specification

Mechanical Specification		
Mass (grams)	16.5	
Dimensions (mm)	15 x 46.00	
Housing Material	Black Anodised Aluminium	
Isolated Body	Yes	
Lead Length (mm)	250	
Optical Options		
Beam Size at Aperture (mm)	5 by 2	
Beam Divergence (mRad)	<0.5	
Minimum Focus Distance (mm)	25	
Spot Size at Minimum Focus (µm)	<50*	
Power Stability Over Temperature Range	±3.6% #	
Bore Sighting (mRad)	≤10	
Environmental Information		
Operating Case Temperature (°C)	635nm & 650nm	-10°C to +45°C (Note 1)
	670nm & 785nm	-10°C to +55°C (Note 1)
Storage Temperature (°C)	-10°C to +80°C	
Operating Humidity (%RH)	90 non condensing	
MTTF @ 25°C	635nm	>29,000 hours
	650nm	>100,000 hours
	670nm	>100,000 hours
	785nm	>90,000 hours
Electrical Specification		
	635nm Models	650, 670 & 780nm Models
Red Lead (Vdc)	+3.5 to +5	N/A
Green Lead (V)	0	0
Black Lead	N/A	-5 to -8
Blue Lead	N/A	TTL Enable
Operating Current at 25°C (mA)	≤70	
Reverse Polarity Protection	Yes	
TTL Disable Input	N/A	Active High
Frequency Range (Hz)	N/A	≤100 #

NOTES

* Varies with Laser Diode Type

Varies with Laser Diode type and output power. This data is based on Beta CW 670nm, 3mW

Note 1: The operating case temperature range is dependant on the laser diode fitted. The quoted information is the typical range. Some wavelengths and powers may have a wider operating temperature range. Please contact us for the temperature range for individual models

Specifications are typical at 25° unless otherwise stated

Mounting Options

Heavy Duty Mounting Clamp

The optional heavy duty mounting clamp allows the Beta CW range to be securely fixed at any required direction or angle. The base plate has a series of threaded holes which allows the clamp to be fixed directly onto a machine or workbench.

Magnetic Mount

A magnetic base is also available which allows the heavy duty clamp to be magnetically attached to a ferrous surface, negating the need for any mounting holes.

Swivel Mount Clamp

The optional swivel clamp allows the Beta CW to be mounted securely. It offers the user up and down movement as well as $\pm 45^\circ$ horizontal swivel. The base plate has a series of holes which allows the clamp to be fixed directly onto a machine or workbench.



Lens Options

Standard Lens:-

S Lens: Produces an elliptical collimated beam or elliptical focused spot.

Optional Collimating Lenses:-

C1 Lens: Collimating lens with an aperture of 1mm which produces a circular collimated beam or focused spot.

C1.5 Lens: Collimating lens with an aperture of 1.5mm which produces a circular collimated beam or focused spot.

C2 Lens: Collimating lens with an aperture of 2mm which produces a circular collimated beam or focused spot.

C3 Lens: Collimating lens with an aperture of 3mm which produces a circular collimated beam or focused spot.

HG Lens: High quality glass aspheric lens which produces a elliptical collimated beam or well defined spot over longer working distance.

Line Lens Assemblies:-

L4 Line Lens: Produces a gaussian line with a full fan angle of typically 8°

L8 Line Lens: Produces a gaussian line with a full fan angle of typically 16°

LW53: Produces a gaussian line with full fan angle of typically 90°

Please note other fan angles are available on request.

Power Options

Wavelength (nm)	Power (mW)
635	0.8, 2.8
650	2.8
670	0.8, 2.8
780	2.8
Custom	Please call with your requirements

Please note that all wavelength tolerance can vary typically by $\pm 10\text{nm}$

Not all the powers are available with all lens options

Laser Safety

Our lasers are compliant to IEC 60825-1 2007 standards. The lasers fall within one of the following classifications depending on power and wavelength.

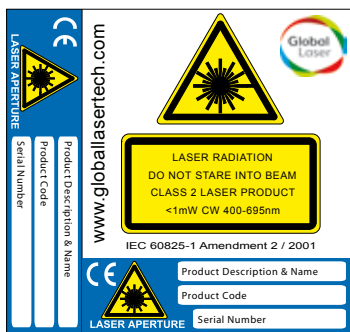

Class 2 Label

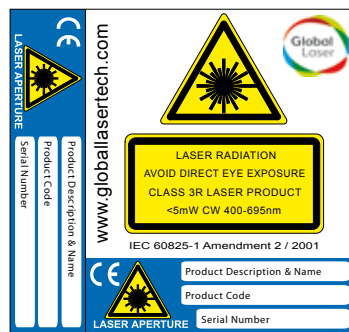

Class 3R Label

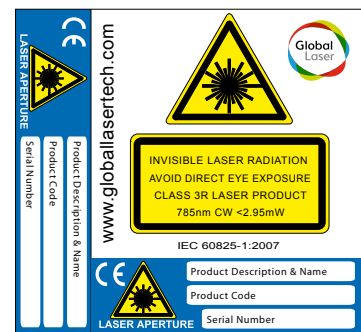

Class 3R 780nm Label

Quality & Warranty

The Beta CW range is supplied with a 12 month parts and labour warranty. Our manufacturing operations are certified to ISO9001.

Mechanical Drawings

Beta CW

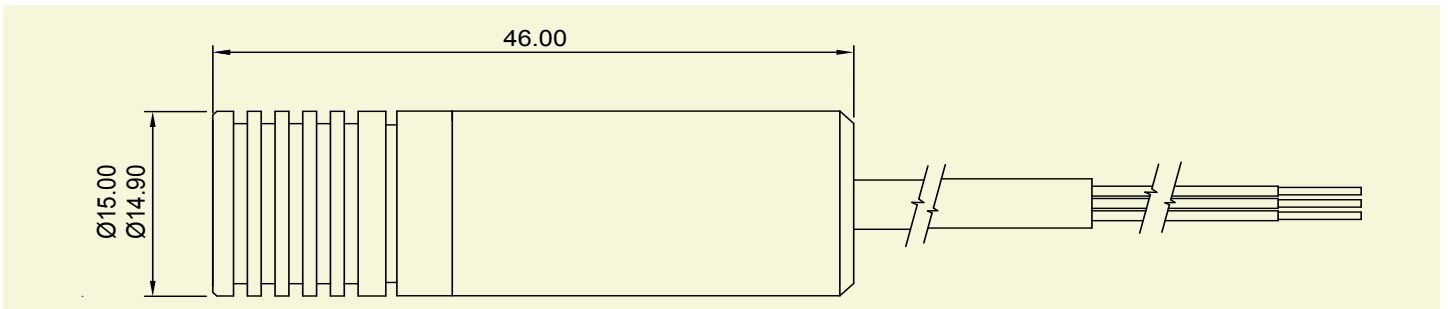

Beta CW with Line Lens

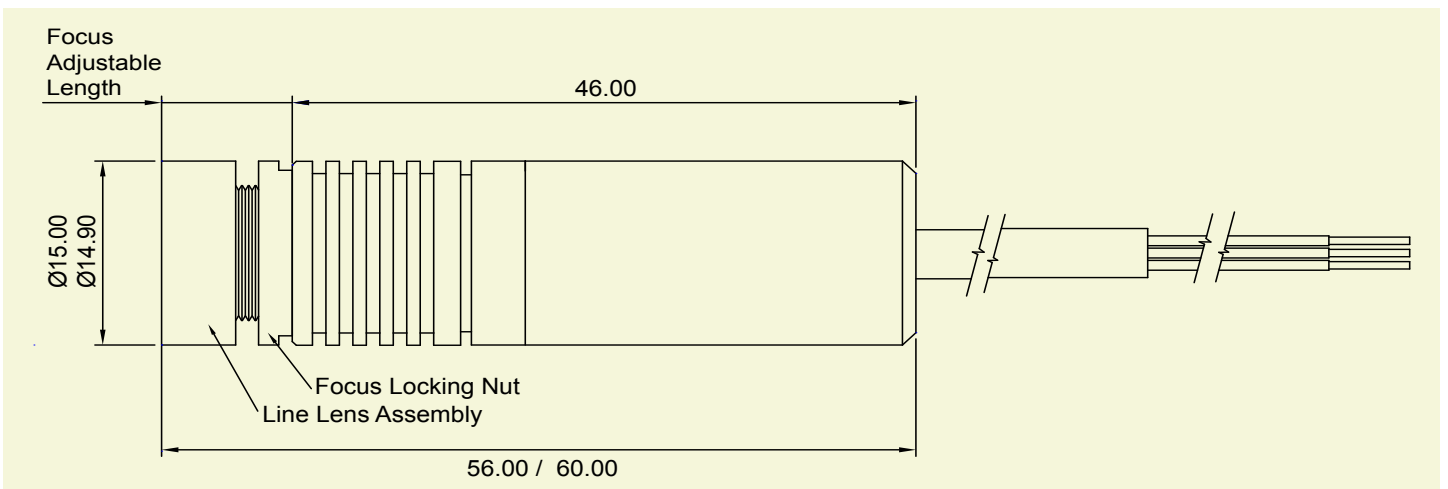

Heavy Duty Mounting Clamp

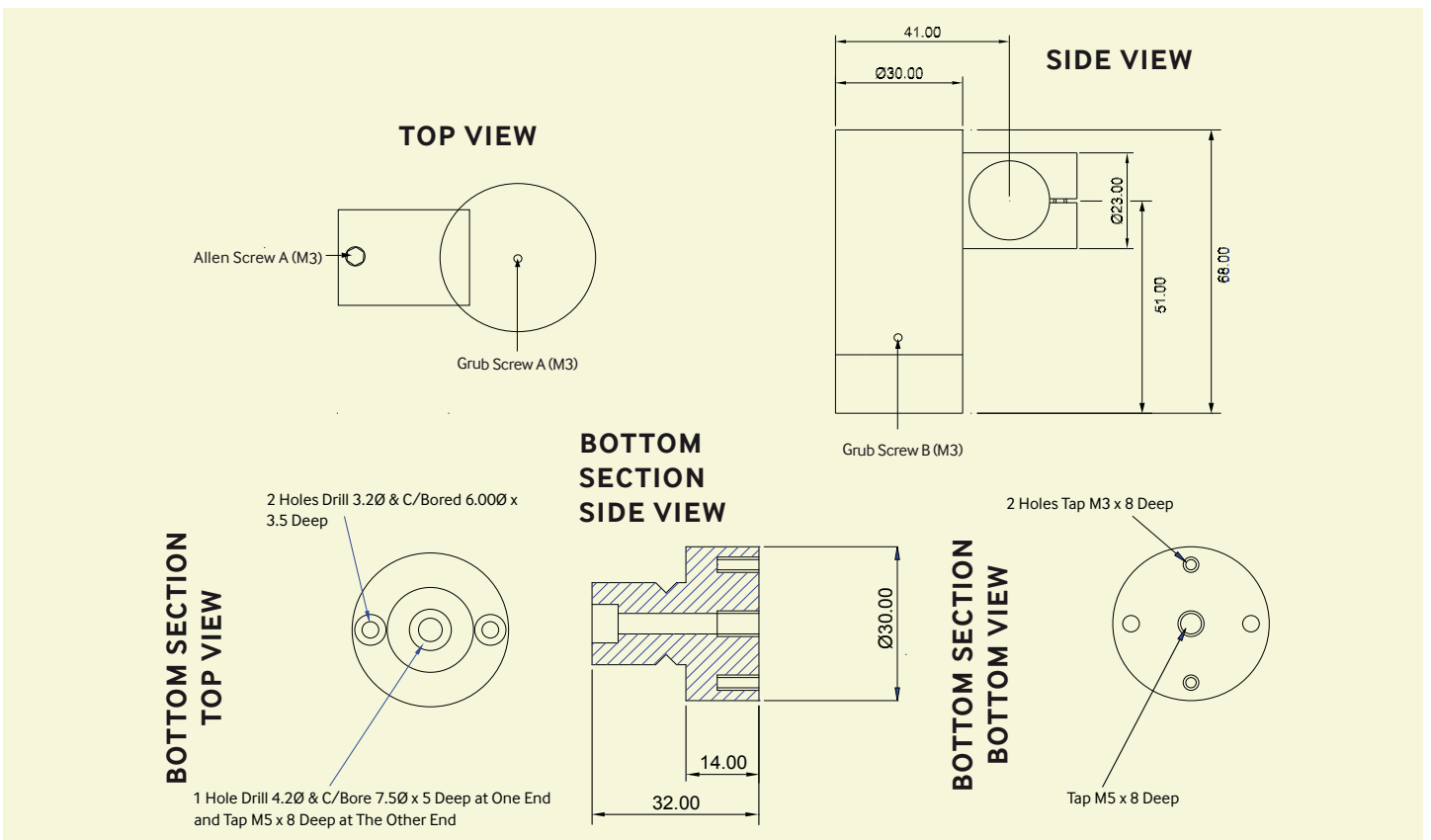

Swivel Mount

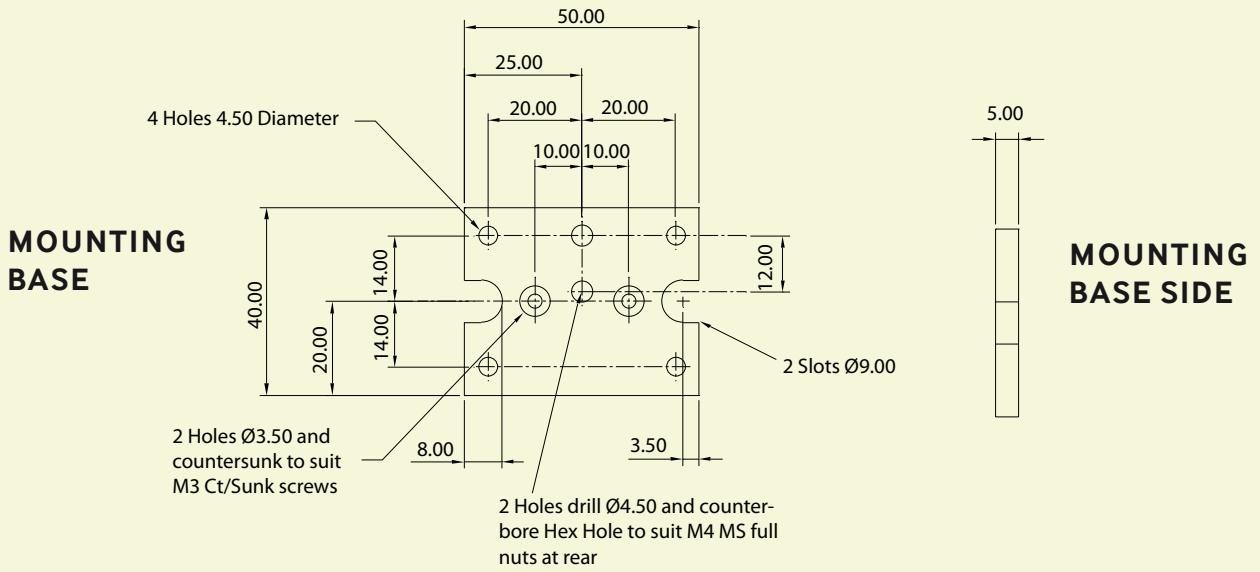
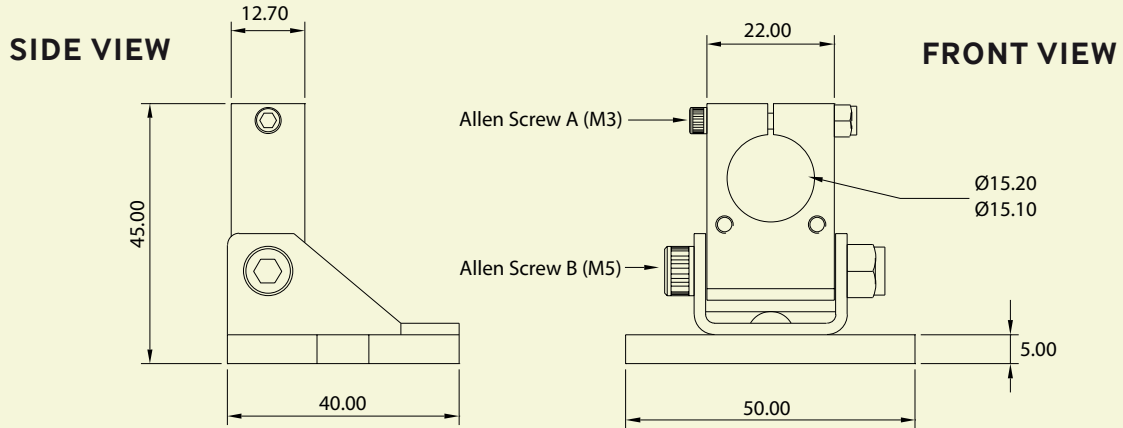

Magnetic Base

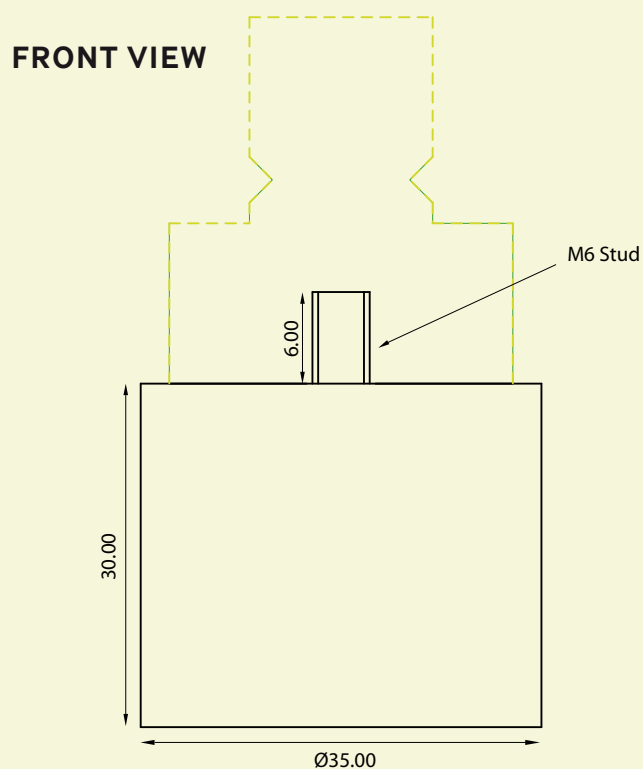

Drawings not to scale

Notes

Please Note: Global Laser reserve the right to change descriptions and specifications without notice.



For further information about any of our products please contact your local distributor or you can contact Global Laser in the UK. Your Local Distributor is:

T: +44 (0)1495 212213
F: +44 (0)1495 214004
E: sales@globallasertech.com
www.globallasertech.com

Global Laser Ltd
Unit 9-10
Roseheyworth Business Park
Abertillery, Gwent NP13 1SP UK