

Zero Differential Pressure Type Pilot Operated 2 Port Solenoid Valve

For Steam



New



Enclosure IP65



Steam

* Can be used with heated water.

Long service life

3 million cycles*1

*1 Based on SMC's test condition

Improved resistance to foreign objects

Double guide rings

- Stable sliding performance
- Improved scraper performance reduces the entry of foreign objects.

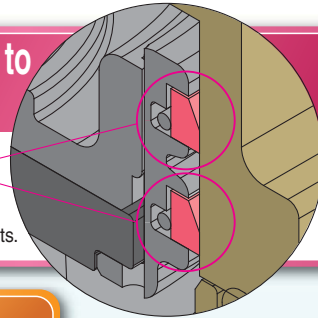

Reduced apparent power

18 VA → **12 VA***2

20 VA → **15 VA***3

*Existing model VXS22 → 2 VXS23/24
*Existing model VXS23 → 3 VXS25/26

Reduced coil temperature rise

120°C → **100°C***4

*Existing model VXS22/23 → 4 VXS23 to 26

24 VDC added



Electrical entry

Grommet/DIN terminal
Conduit terminal/Conduit



DIN terminal added



Body material

C37 (Brass), Stainless steel

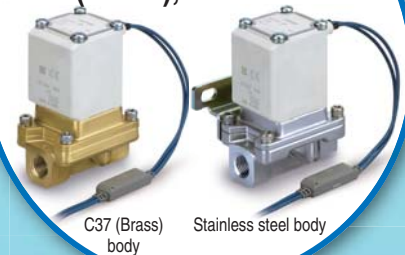

C37 (Brass) body

Stainless steel body

High sealing performance

Internal leakage (Air)

1.0 cm³/min or less

Full-wave rectifier standardised

- Improved durability
- Reduced buzz noise
- Low-noise construction

Series VXS



CAT.EUS70-52A-UK

Zero Differential Pressure Type Pilot Operated 2 Port Solenoid Valve *Series VXS*



Enclosure
IP65

Flame resistance
UL94V-0 conformed

Flame resistant mold coil material

24 VDC,
DIN terminal
standardised

Rubber seal
(special FKM) with high
sealing performance

Internal leakage (Air)
1.0 cm³/min or less

Reliability is improved due to a piston main valve and a rubber seal made of special FKM.

Double guide rings

- Stable sliding performance
- Improved scraper performance reduces the entry of foreign objects.

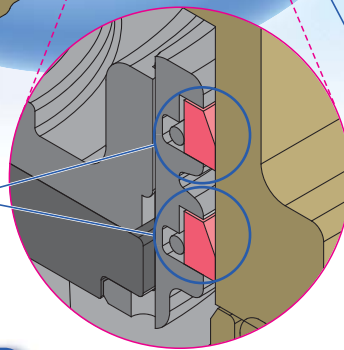

Clearance

Reduced power consumption

18 VA → **12 VA***1

20 VA → **15 VA***2

*Existing model VXS22 → 1 VXS23/24

*Existing model VXS23 → 2 VXS25/26

Reduced coil temperature rise

120°C → **100°C***3

*Existing model VXS22/23 → 3 VXS23 to 26

Improved armature durability

Low-noise construction

Noise reduction and low impact due to bumper

By providing a bumper and clearance, we reduced the collision sound of the core when ON (when the valve is open).

Body material

C37 (Brass),
Stainless steel

Built-in full-wave rectifier type (AC specification)

Improved durability

Service life is extended by the special construction. (compared with current shading coil)

Reduced buzz noise

Rectified to DC by the full-wave rectifier, resulting in a buzz noise reduction.

Low-noise construction

Specially constructed to reduce the impact noise during operation.

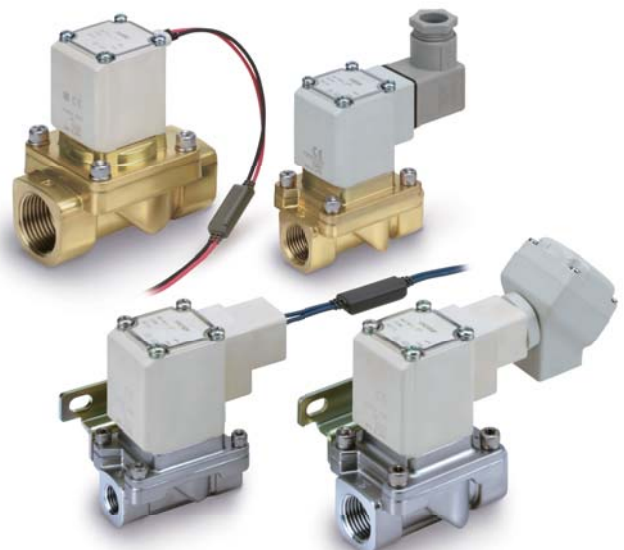

Model	Size	Orifice diameter [mm]	Port size	Body material	Fluid
VXS23	10A	10	1/4, 3/8	C37 (Brass)	
				Stainless steel	
VXS24	15A	15	1/2	C37 (Brass)	
				Stainless steel	
VXS25	20A	20	3/4	C37 (Brass)	
				Stainless steel	
VXS26	25A	25	1	C37 (Brass)	
				Stainless steel	

Variations

Series

Direct Operated

Series VX

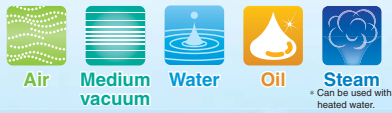

Compact Series VDW



Valve type	Port size	Orifice diameter [mm]
N.C./N.O.	1/8, 1/4, 3/8, 1/2, ø6, ø8, ø10, ø12	2, 3, 4, 5, 7, 8, 10

Valve type	Port size				Orifice diameter [mm]
	Common SUP type		Individual SUP type		
	IN	OUT	IN	OUT	
N.C./N.O.	3/8	1/8 1/4	1/8 1/4	3/8	2, 3, 4, 5, 7

Valve type	Port size	Orifice diameter [mm]
N.C.	M5, 1/8, ø3.2, ø4, ø6	1, 1.6, 2.3, 3.2

Pilot Operated

Series VXD



Zero differential pressure Series VXZ



Valve type	Port size	Orifice diameter [mm]
N.C./N.O.	1/4, 3/8, 1/2, 3/4, 1, Ø 10, Ø 3/8", Ø 12	10, 15, 20, 25

Valve type	Port size	Orifice diameter [mm]
N.C./N.O.	1/4, 3/8, 1/2, 3/4, 1, ø10, ø12, ø3/8"	10, 15, 20, 25

Fluid/Orifice Diameter

	Series	Applicable fluid	Orifice diameter [mm]				
			1	5	10	20	50
Direct Operated	Series VX* * For single unit	Air, Medium vacuum, Water, Oil, Steam (Can be used with heated water.)	2	10			
	Series VDW	Air, Medium vacuum, Water	1	3.2			
Pilot Operated	Series VXD	Air, Water, Oil, Heated water, High temperature oil			10	25	
	Series VXZ	Air, Water, Oil, Heated water, High temperature oil			10	25	

INDEX

Zero Differential Pressure Type Pilot Operated 2 Port Solenoid Valve *Series VXS*

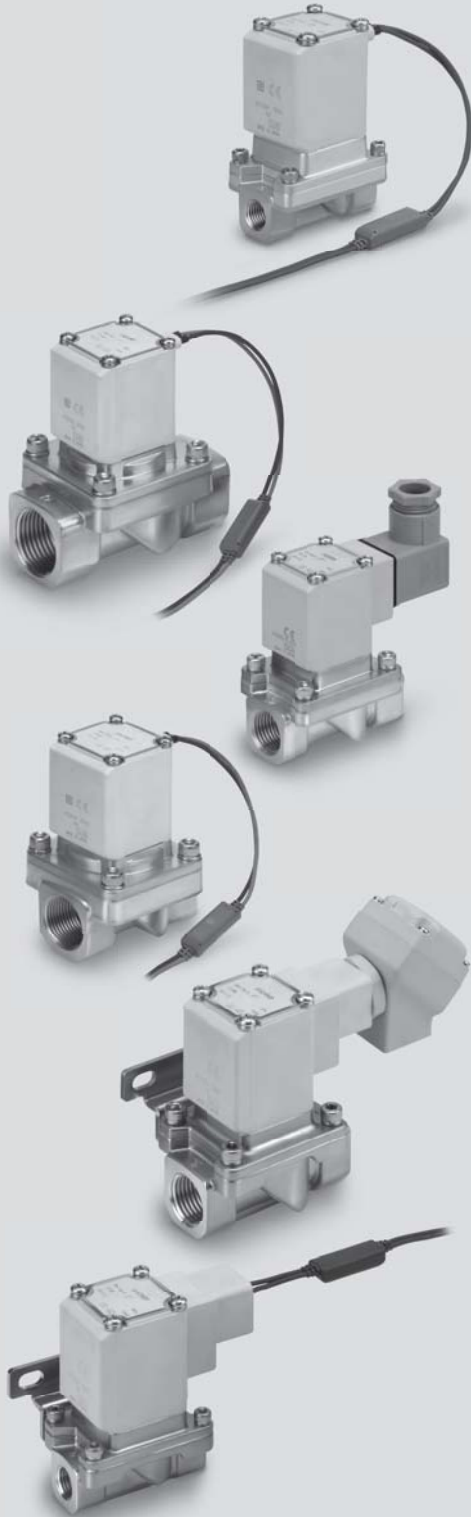

Common Specifications P. 2

Selection Steps P. 2



For Steam

Model/Valve Specifications, Fluid and Ambient Temperature,
Valve Leakage Rate P. 3

How to Order P. 4

Construction P. 6

Dimensions

Body material: C37 (Brass), Stainless steel P. 7

Replacement Parts P. 8

Glossary of Terms P. 9

Solenoid Valve Flow-rate Characteristics P. 10

Flow-rate Characteristics P. 12

Specific Product Precautions P. 13

Safety Instructions Back cover

Specifications

For Steam

Options

Construction

Dimensions

Series VXS

Common Specifications/Selection Steps

Standard Specifications

Valve specifications	Valve construction		Zero differential pressure type pilot operated piston type
	Withstand pressure (with water pressure)		2.0 MPa
	Body material		C37 (Brass), Stainless steel
	Seal material		FKM
	Enclosure		Dust-tight, Water-jet-proof type (IP65)
	Environment		Location without corrosive or explosive gases
Coil specifications	Rated voltage	AC	24 VAC, 48 VAC, 100 VAC, 110 VAC, 200 VAC, 220 VAC, 230 VAC, 240 VAC
		DC	24 VDC
	Allowable voltage fluctuation		±10% of rated voltage
	Allowable leakage voltage	AC (Built-in full-wave rectifier type)	5% or less of rated voltage
		DC	2% or less of rated voltage
Coil insulation type		Class H	

⚠ Be sure to read “Specific Product Precautions” before handling.

⚠ When pressure differential is less than 0.01 MPa, operation may become unstable. Please contact SMC in case of low flow operation. (Refer to page 6.)

Solenoid Coil Specifications

Normally Closed (N.C.)

DC Specification

Model	Power consumption [W] <small>Note 1)</small>	Temperature rise [°C] <small>Note 2)</small>
VXS23/24	12	100
VXS25/26	15	100

Note 1) The value at ambient temperature of 20°C and when the rated voltage is applied. (Variation: ±10%)

Note 2) The value at ambient temperature of 20°C and when the rated voltage is applied. The value depends on the ambient environment. This is for reference.

AC Specification (Built-in Full-wave Rectifier Type)

Model	Apparent power [VA] <small>Note 1) 2)</small>	Temperature rise [°C] <small>Note 3)</small>
VXS23/24	12	100
VXS25/26	15	100

Note 1) The value at ambient temperature of 20°C and when the rated voltage is applied. (Variation: ±10%)

Note 2) There is no difference in the frequency and the inrush and energised apparent power, since a rectifying circuit is used in the AC (Built-in full-wave rectifier type).

Note 3) The value at ambient temperature of 20°C and when the rated voltage is applied. The value depends on the ambient environment. This is for reference.

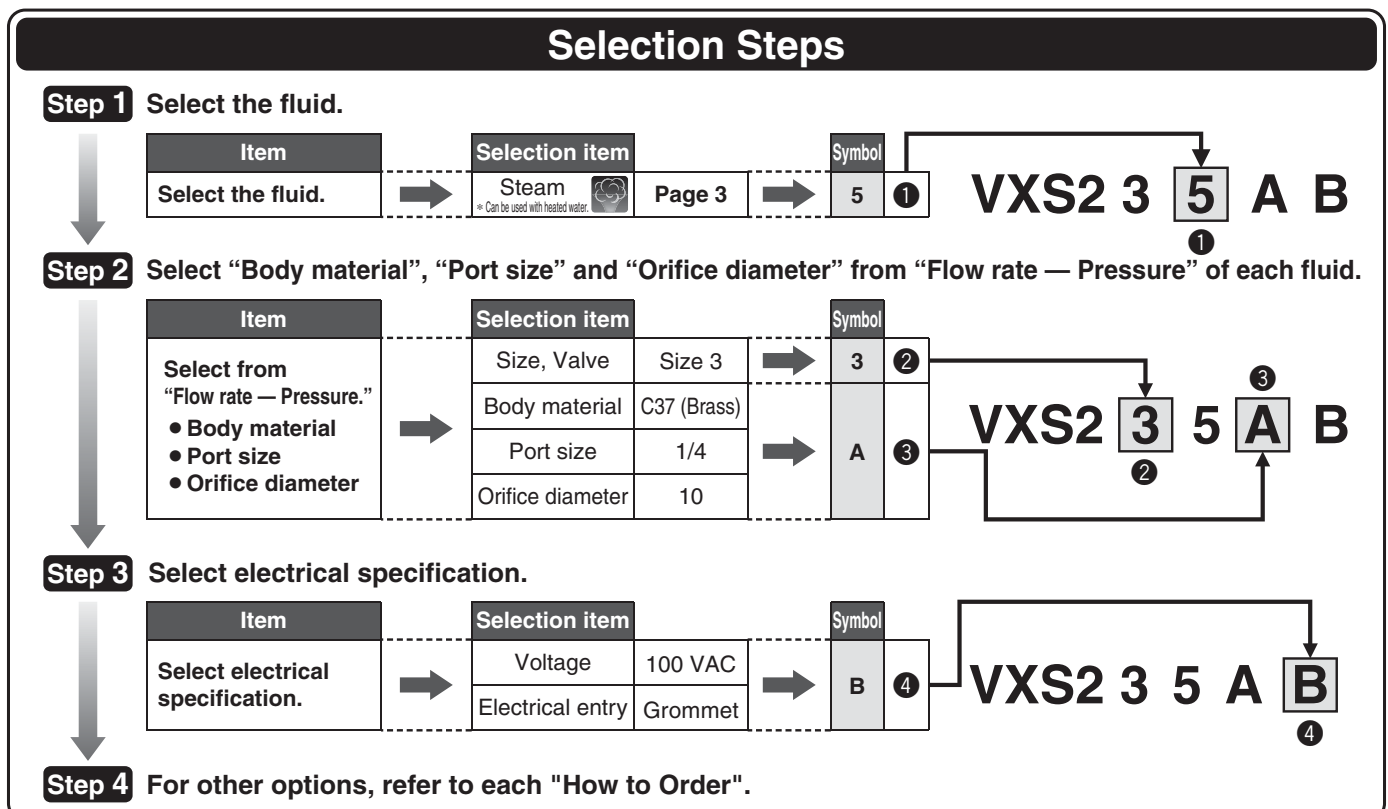



For Steam

* Can be used with heated water.

Specifications

For Steam

Model/Valve Specifications

N.C.

Symbol

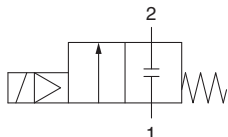

When the valve is closed, flow is blocked from port 1 to port 2. However, if the pressure in port 2 is higher than port 1, the valve will not be able to block the fluid and it will flow from port 2 to port 1.

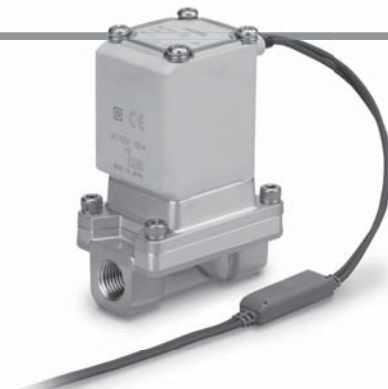

Normally Closed (N.C.)

Body material	Size	Port size (Nominal diameter)	Orifice diameter [mm]	Model	Min. operating pressure differential ^{Note 1)} [MPa]	Max. operating pressure differential (MPa)		Flow-rate characteristics		Max. system pressure [MPa]	Weight ^{Note 2)} [g]
						AC	DC	Av x 10 ⁻⁶ m ²	Cv		
C37 (Brass), Stainless steel	3	1/4 (8A)	10	VXS235	0	1.0		58	2.4	1.0	600
		3/8 (10A)						67	2.8		720
	4	1/2 (15A)	15	VXS245				130	5.3		1100
	5	3/4 (20A)	20	VXS255				220	9.2		1300
	6	1 (25A)	25	VXS265				290	12.0		

Note 1) The operation of the valve may be unstable due to the capacity of the pressure supply source such as pumps and boilers or the pressure loss by the orifice of piping. Please contact SMC to check if the required valve size can be used in the application. Please contact SMC for the compatibility of the circuit flow and valve size. (Refer to page 6.)

Note 2) Weight of grommet type. Add 10 g for conduit, 30 g for DIN terminal, and 60 g for conduit terminal type respectively.

• Refer to "Glossary of Terms" on page 9 for details on the maximum operating pressure differential.

Options

Construction

Fluid and Ambient Temperature

Fluid	Temperature [°C]	Ambient temperature [°C]
Steam	183 or less	-20 to 60
Heated water	99 or less	

Note) With no freezing

Valve Leakage Rate

Internal Leakage

Fluid	Seal material	Leakage rate
Steam	FKM	1 cm ³ /min or less
Heated water		0.1 cm ³ /min or less

External Leakage

Fluid	Seal material	Leakage rate
Steam	FKM	1 cm ³ /min or less
Heated water		0.1 cm ³ /min or less

Note) Leakage is the value at ambient temperature 20°C.

Dimensions

Series VXS



How to Order

VXS2 **3** **5** **A** **B**

Common Specifications

Seal material	FKM
---------------	-----

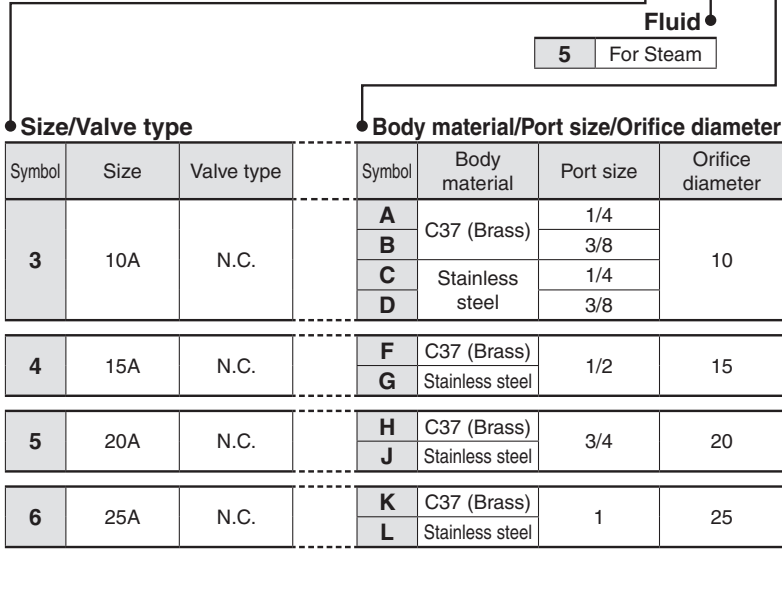

Other options

Symbol	Oil-free	Port thread
—	—	Rc
A	—	G
B	—	NPT
D	○	G
E	○	NPT
Z	○	Rc

Voltage/Electrical entry

(coil insulation type: class H)

Symbol	Voltage	Electrical entry
A	24 VDC	Grommet
B	100 VAC	Grommet (With surge voltage suppressor)
C	110 VAC	
D	200 VAC	
E	230 VAC	
G	24 VDC	DIN terminal (With surge voltage suppressor Note 1) 2)
H	100 VAC	
J	110 VAC	
K	200 VAC	
L	230 VAC	Conduit terminal (With surge voltage suppressor)
N	100 VAC	
P	110 VAC	
Q	200 VAC	
R	230 VAC	Conduit (With surge voltage suppressor)
T	100 VAC	
U	110 VAC	
V	200 VAC	
W	230 VAC	

Symbol	Voltage	Electrical entry
Z1A	48 VAC	Grommet (With surge voltage suppressor)
Z1B	220 VAC	
Z1C	240 VAC	
Z1U	24 VAC	
Z1F	48 VAC	DIN terminal (With surge voltage suppressor)
Z1G	220 VAC	
Z1H	240 VAC	
Z1V	24 VAC	
Z1K	48 VAC	Conduit terminal (With surge voltage suppressor)
Z1L	220 VAC	
Z1M	240 VAC	
Z1W	24 VAC	
Z1P	48 VAC	Conduit (With surge voltage suppressor)
Z1Q	220 VAC	
Z1R	240 VAC	
Z1Y	24 VAC	

Symbol	Voltage	Electrical entry
Z2A	24 VDC	DIN terminal (With surge voltage suppressor with light)
Z2B	100 VAC	
Z2C	110 VAC	
Z2D	200 VAC	
Z2E	230 VAC	DIN terminal (With surge voltage suppressor with light)
Z2F	48 VAC	
Z2G	220 VAC	
Z2H	240 VAC	
Z2V	24 VAC	Conduit terminal (With surge voltage suppressor with light)
Z2L	100 VAC	
Z2M	110 VAC	
Z2N	200 VAC	
Z2P	230 VAC	
Z2Q	48 VAC	
Z2R	220 VAC	
Z2S	240 VAC	
Z2W	24 VAC	

Note 1) Coil for DIN terminal H type with AC voltage does not have full-wave rectifier. Full-wave rectifier is built in the DIN connector. Refer to page 8 to order it as an accessory.

Note 2) DIN connector insulation class is Class "B".

Note 3) Faston terminal is not available.

For other special options, refer to page 5.

With bracket
Special electrical entry direction

Series VXS

Other Special Options

Installation options (Mounting option/Special electrical entry direction)

The following shows combinations that can be selected using installation options.

Combinations

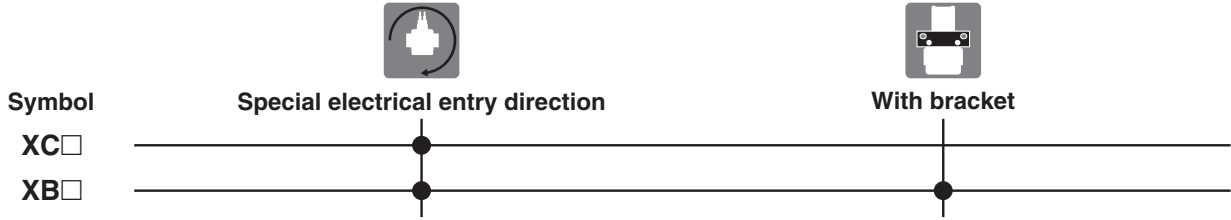

Special Electrical Entry Direction

VXS2 XC A

Enter standard product number.

Symbol	Rotation angle
A	90°
B	180°
C	270°

*1 Available for the VXS23 to 26.

With Bracket/ Special Electrical Entry Direction

VXS2 XB A

Enter standard product number.

Symbol	Rotation angle
—	Standard
A	90°
B	180°
C	270°

*1 Available for the VXS23 to 26.

*2 Bracket is packed in the same container as the main body.

How to mount a bracket

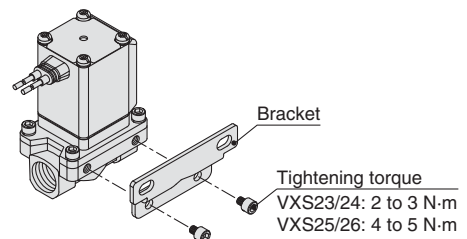

* Enter symbols in the order below when ordering a combination of electrical option, other option, etc.

Example) VXS2 3 5 A Z 1A Z XB A

Electrical option ●
Other option ●
Special electrical entry direction ●
With bracket ●

Specifications

For Steam

Options

Construction

Dimensions

Series VXS



Construction/Normally Closed (N.C.)

Body material: C37 (Brass), Stainless steel

Component Parts

No.	Description	Material
1	Solenoid coil	Cu + Fe + Resin
2	Coil cover	Stainless steel
3	Tube assembly	Stainless steel
4	Return spring	Stainless steel
5	Armature/Piston assembly	Stainless steel, FKM
6	Stopper	FKM
7	Bonnet	C37 (Brass), Stainless steel
8	Body	C37 (Brass), Stainless steel
9	O-ring	FKM

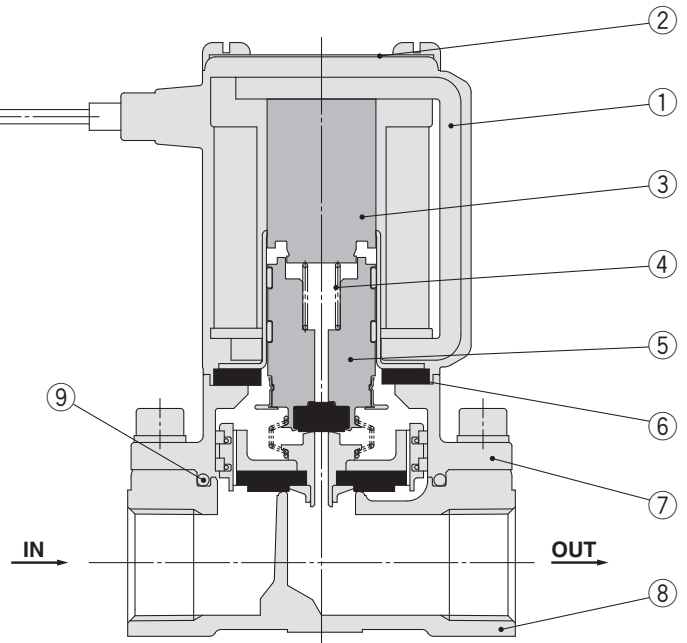

Working Principle

De-energised

The fluid enters from the IN goes through the supply orifice to fill the pressure action chamber. Main valve is closed by the pressure in the pressure action chamber and the reaction force of the return spring.

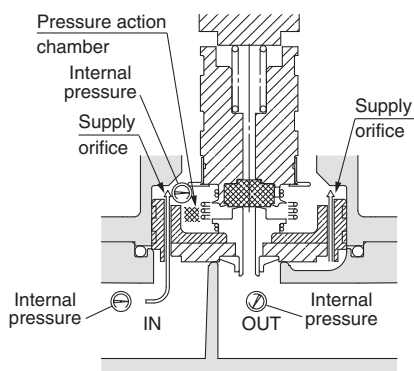

Right after energised (Pilot valve open)

When the coil is energised, the armature is attracted causing the pilot orifice to opening. The fluid filling the pressure action chamber flows to the OUT side through the pilot orifice.

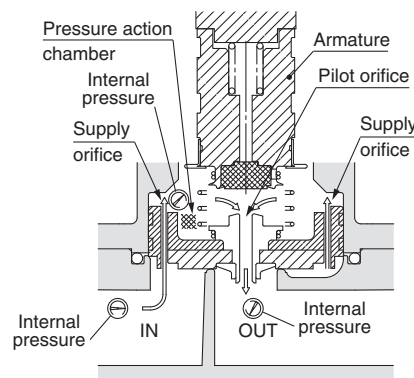

Energised (Main valve side)

The pressure in the pressure action chamber decreases by discharging fluid through the pilot orifice. Because the force which pushes down the valve is reduced by the discharge of the fluid, the force that pushes up the main valve overcomes the push down force and opens the main valve. The main valve opens by the lift spring reaction force even if pressure on the IN side is 0 MPa or very low pressure.

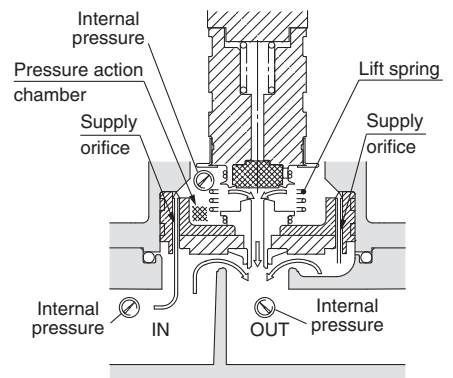

⚠ Warning

Unstable flow may occur with the product under the following conditions: • low flow from the pump or boiler, etc. • use of several elbows or tees in the circuit, or • thin nozzles installed at the end of the piping etc. This can cause valve opening/closing failure, or oscillation, and cause a valve malfunction. If products are used with vacuum, then the vacuum level can be unstable due to these conditions. Please contact SMC to check if the valve can be used in the application by providing the relevant fluid circuit.



Dimensions/Body Material: C37 (Brass), Stainless Steel

Grommet

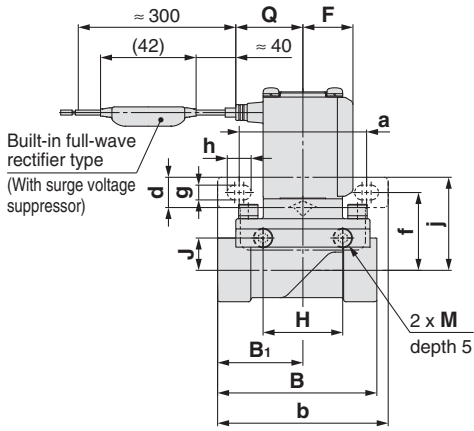

Conduit terminal

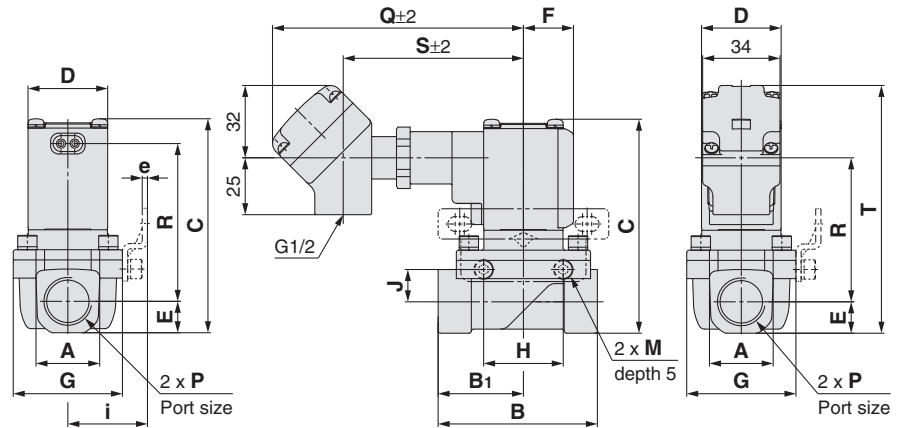

Conduit

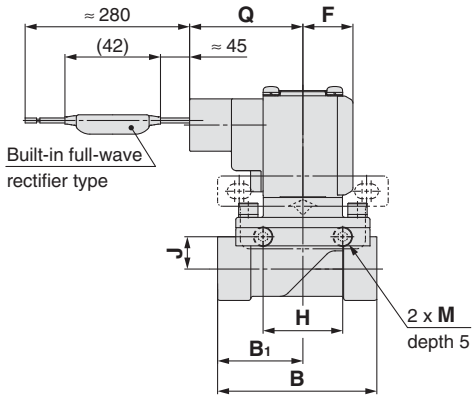

DIN terminal

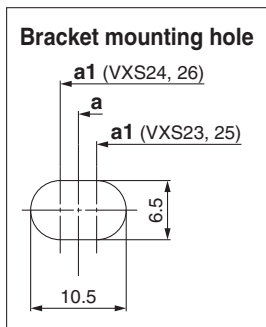
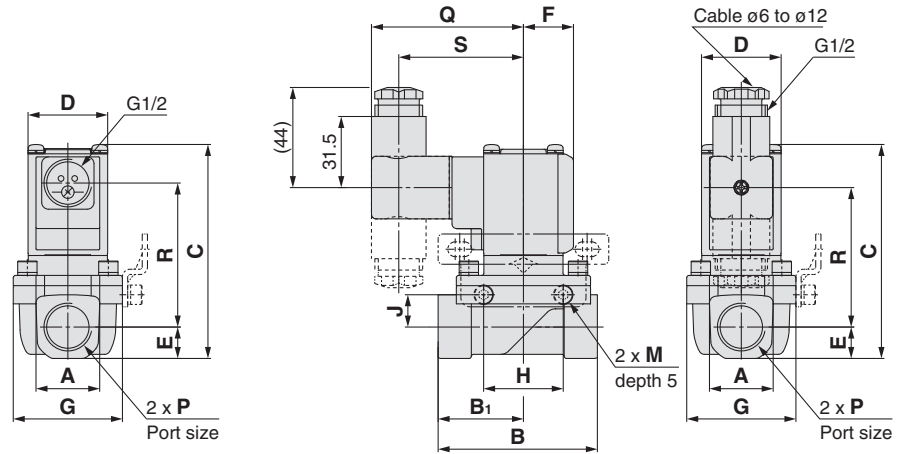

Dimensions

Model	Port size P	A	B	B ₁	C	D	E	F	G	H	J	M	Bracket mounting [mm]								
													a	b	d	e	f	g	h	i	j
VXS23	1/4, 3/8	21	57	28.5	87.5	35	10.5	22	40	35	10	M5	56	75	13.5	2.3	30	6.5	10.5	31	37
VXS24	1/2	28	70	37.5	94	35	14	22	48	35	14	M5	56	75		2.3	34	6.5	10.5	35	41
VXS25	3/4	33.5	71	38.5	105.5	40	17	24.5	62	33	15.2	M6	70.5	92		2.3	39	6.5	10.5	43	46
VXS26	1	42	95	49.5	111.5	40	20	24.5	66	37	17.2	M6	70.5	92		2.3	41	6.5	10.5	45	48

Model	Port size P	Electrical entry										
		Grommet		DIN terminal			Conduit terminal			Conduit		
		Q	R	Q	R	S	Q	R	S	T	Q	R
VXS23	1/4, 3/8	29.5	66	67	58	55	110.5	60	79.5	102.5	50	60
VXS24	1/2	29.5	69.5	67	61.5	55	110.5	63.5	79.5	109	50	63.5
VXS25	3/4	32	78	69.5	70	57.5	113	72	82	120.5	52.5	72
VXS26	1	32	81	69.5	72.5	57.5	113	74.5	82	126.5	52.5	74.5

Specifications

For Steam

Options

Construction

Dimensions

Series VXS



Replacement Parts

• DIN Connector Part No.

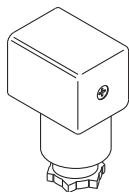

<Coil Insulation Type/Class H>

Electrical option	Rated voltage	Connector part no.
None	24 VDC	GDM2A-G-S5
	100 VAC	GDM2A-R
	110 VAC	
	200 VAC	
	220 VAC	
	230 VAC	
	240 VAC	
	24 VAC	
	48 VAC	
With light	24 VDC	GDM2A-G-Z5
	100 VAC	GDM2A-R-L1
	110 VAC	GDM2A-R-L1
	200 VAC	GDM2A-R-L2
	220 VAC	GDM2A-R-L2
	230 VAC	GDM2A-R-L2
	240 VAC	GDM2A-R-L2
	24 VAC	GDM2A-R-L5
	48 VAC	GDM2A-R-L5

• Gasket Part No. for DIN Connector

VCW20-1-29-1-F

• Bracket Assembly Part No.

VXZ 3 0S-14A-1

3	VXS2 $\frac{3}{4}$ 5□
5	VXS2 $\frac{5}{8}$ 5□

* 2 mounting screws are shipped together with the bracket assembly.

Glossary of Terms

Pressure Terminology

1. Maximum operating pressure differential

The maximum pressure differential (the difference between the inlet and outlet pressure) which is allowed for operation. When the outlet pressure is 0 MPa, this becomes the maximum operating pressure.

2. Minimum operating pressure differential

The minimum pressure differential (the difference between the inlet pressure and outlet pressure) required to keep the main valve fully open.

3. Maximum system pressure

The maximum pressure that can be applied inside the pipelines (line pressure).

[The pressure differential of the solenoid valve portion must be less than the maximum operating pressure differential.]

4. Withstand pressure

The pressure in which the valve must be withstood without a drop in performance after holding for one minute under prescribed pressure (static pressure) and returning to the operating pressure range. [value under the prescribed conditions]

Electrical Terminology

1. Apparent power [VA]

Volt-ampere is the product of voltage [V] and current [A].
Power consumption [W]: For AC, $W = V \cdot A \cdot \cos\theta$. For DC, $W = V \cdot A$.

Note) $\cos\theta$ shows power factor. $\cos\theta \approx 0.9$

2. Surge voltage

A high voltage which is momentarily generated by shutting off the power in the shut-off area.

3. Degree of protection

A degree defined in the "JIS C 0920: Waterproof test of electric machinery/appliance and the degree of protection against the intrusion of solid foreign objects."

Verify the degree of protection for each product.

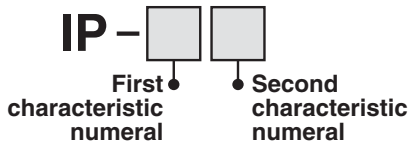

● First Characteristics: Degrees of protection against solid foreign objects

0	Non-protected
1	Protected against solid foreign objects of 50 mmø and greater
2	Protected against solid foreign objects of 12 mmø and greater
3	Protected against solid foreign objects of 2.5 mmø and greater
4	Protected against solid foreign objects of 1.0 mmø and greater
5	Dust-protected
6	Dust-tight

Electrical Terminology

● Second Characteristics: Degrees of protection against water

0	Non-protected	—
1	Protected against vertically falling water drops	Drip-proof type 1
2	Protected against vertically falling water drops when enclosure tilted up to 15°	Drip-proof type 2
3	Protected against rainfall when enclosure tilted up to 60°	Rain-proof type
4	Protected against splashing water	Splash-proof type
5	Protected against water jets	Water-jet-proof type
6	Protected against powerful water jets	Powerful water-jet-proof type
7	Protected against the effects of temporary immersion in water	Immersion type
8	Protected against the effects of continuous immersion in water	Submersible type

Example) IP65: Dust-tight, Water-jet-proof type

“Water-jet-proof type” means that no water intrudes inside an equipment that could hinder from operating normally by means of applying water for 3 minutes in the prescribed manner. Take appropriate protection measures, since a device is not usable in an environment where a droplet of water is splashed constantly.

Others

1. Material

FKM: Fluororubber

2. Oil-free treatment

The degreasing and washing of wetted parts

3. Symbol

When the valve is closed, flow is blocked from port 1 to port 2. However, if the pressure in port 2 is higher than port 1, the valve will not be able to block the fluid and it will flow from port 2 to port 1.

Solenoid Valve Flow-rate Characteristics

(How to indicate flow-rate characteristics)

1. Indication of flow-rate characteristics

The flow-rate characteristics in equipment such as a solenoid valve etc., are indicated in their specifications as shown in Table (1).

Table (1) Indication of Flow-rate Characteristics

Corresponding equipment	Indication by international standard	Other indications	Conformed standard
Process fluid control equipment	<i>Av</i>	—	IEC60534-2-3: 1997 JIS B 2005: 1995 Equipment: JIS B 8471, 8472, 8473
	—	<i>Cv</i>	
Pneumatic equipment	<i>C, b</i>	—	ISO 6358: 1989 JIS B 8390: 2000
	—	<i>S</i>	JIS B 8390: 2000 Equipment: JIS B 8373, 8374, 8375, 8379, 8381
		<i>Cv</i>	ANSI/(NFPA) T3.21.3: 1990

2. Process fluid control equipment

(1) Conformed standard

IEC60534-2-3: 1997: Industrial-process control valves. Part 2: Flow capacity, Section Three-Test procedures

JIS B 2005: 1995: Test method for the flow coefficient of a valve

Equipment standards: JIS B 8471: Solenoid valve for water

JIS B 8472: Solenoid valve for steam

JIS B 8473: Solenoid valve for fuel oil

(2) Definition of flow-rate characteristics

Av factor: Value of the clean water flow rate represented by m³/s which runs through a valve (equipment for test) when the pressure differential is 1 Pa. It is calculated using the following formula.

$$Av = Q \sqrt{\frac{\rho}{\Delta P}} \dots\dots\dots (1)$$

Av : Flow coefficient [m²]

Q : Flow rate [m³/s]

ΔP : Pressure differential [Pa]

ρ : Fluid density [kg/m³]

(3) Formula of flow rate

It is described by the practical units. Also, the flow-rate characteristics are shown in Graph (1).

In the case of liquid:

$$Q = 1.9 \times 10^6 Av \sqrt{\frac{\Delta P}{G}} \dots\dots\dots (2)$$

Q : Flow rate [L/min]

Av : Flow coefficient [m²]

ΔP : Pressure differential [MPa]

G : Relative density [water = 1]

In the case of saturated steam:

$$Q = 8.3 \times 10^6 Av \sqrt{\Delta P (P_2 + 0.1)} \dots\dots\dots (3)$$

Q : Flow rate [kg/h]

Av : Flow coefficient [m²]

ΔP : Pressure differential [MPa]

P₁ : Upstream pressure [MPa] : **ΔP = P₁ - P₂**

P₂ : Downstream pressure [MPa]

Conversion of flow coefficient:

$$Av = 28 \times 10^{-6} Kv = 24 \times 10^{-6} Cv \dots\dots\dots (4)$$

Here, **Kv** factor : Value of the clean water flow rate represented by m³/h which runs through a valve at 5 to 40°C, when the pressure differential is 1 bar.

Cv factor (Reference values): Figures representing the flow rate of clean water by US gal/min which runs through a valve at 60°F, when the pressure differential is 1 lbf/in² (psi).

Value is different from **Kv** and **Cv** factors for pneumatic purpose due to different test method.

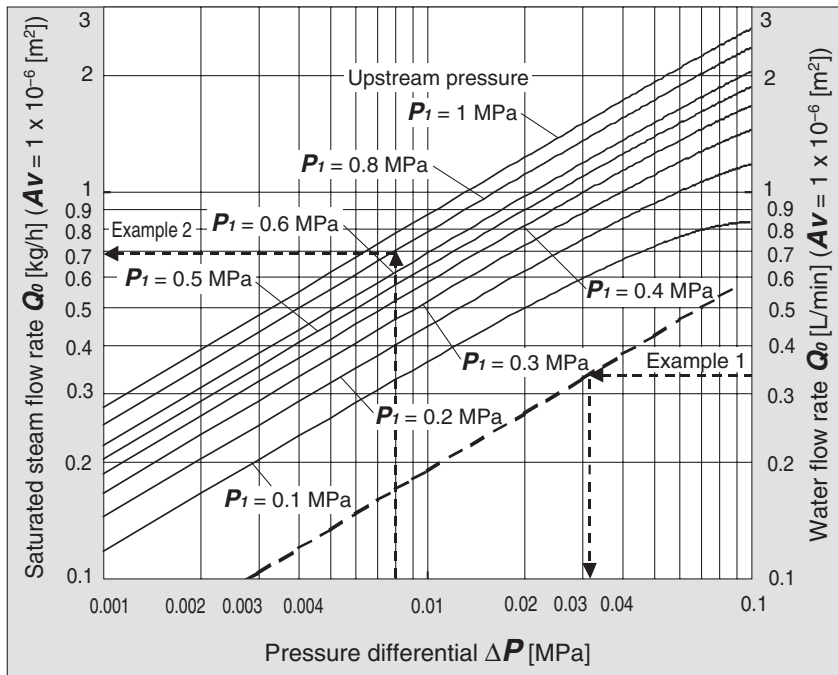

Graph (1) Flow-rate characteristics

Example 1)

Obtain the pressure differential when water 15 [L/min] runs through a solenoid valve with an $Av = 45 \times 10^{-6} [m^2]$. Since $Q_0 = 15/45 = 0.33 [L/min]$, according to Graph (1), if reading ΔP when Q_0 is 0.33, it will be 0.031 [MPa].

Example 2)

Obtain the saturated steam flow rate when $P_1 = 0.8 [MPa]$, $\Delta P = 0.008 [MPa]$ with a solenoid valve with an $Av = 1.5 \times 10^{-6} [m^2]$. According to Graph (1), if reading Q_0 when P_1 is 0.8 and ΔP is 0.008, it is 0.7 [kg/h]. Therefore, the flow rate $Q = 0.7 \times 1.5 = 1.05 [kg/h]$.

(4) Test method

Attach a test equipment with the test circuit shown in Fig. (2). Next, pour water at 5 to 40°C, then measure the flow rate with a pressure differential of 0.075 MPa. However, the pressure differential needs to be set with a large enough difference so that the Reynolds number does not go below a range of 4×10^4 .

By substituting the measurement results for formula (1) to figure out **Av**.

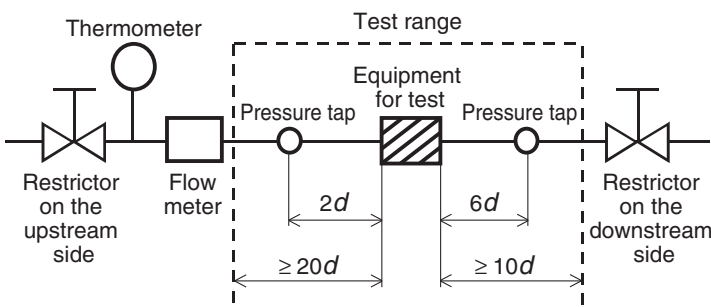
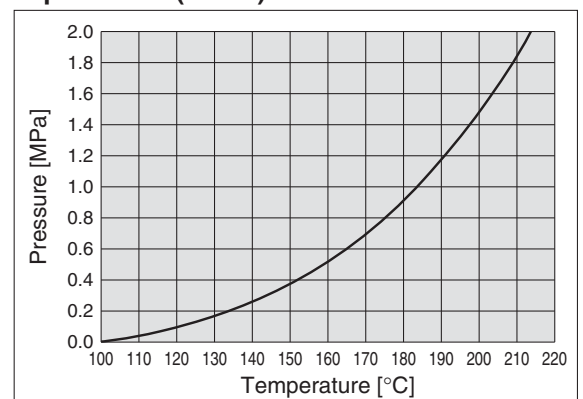

Fig. (2) Test circuit based on IEC60534-2-3, JIS B 2005

Vapor Dome (Water)



The above chart is calculated using the Antoine equation.

Series VXS

Flow-rate Characteristics

Note) Use this graph as a guide. In the case of obtaining an accurate flow rate, refer to pages 10 and 11.

For Saturated Steam

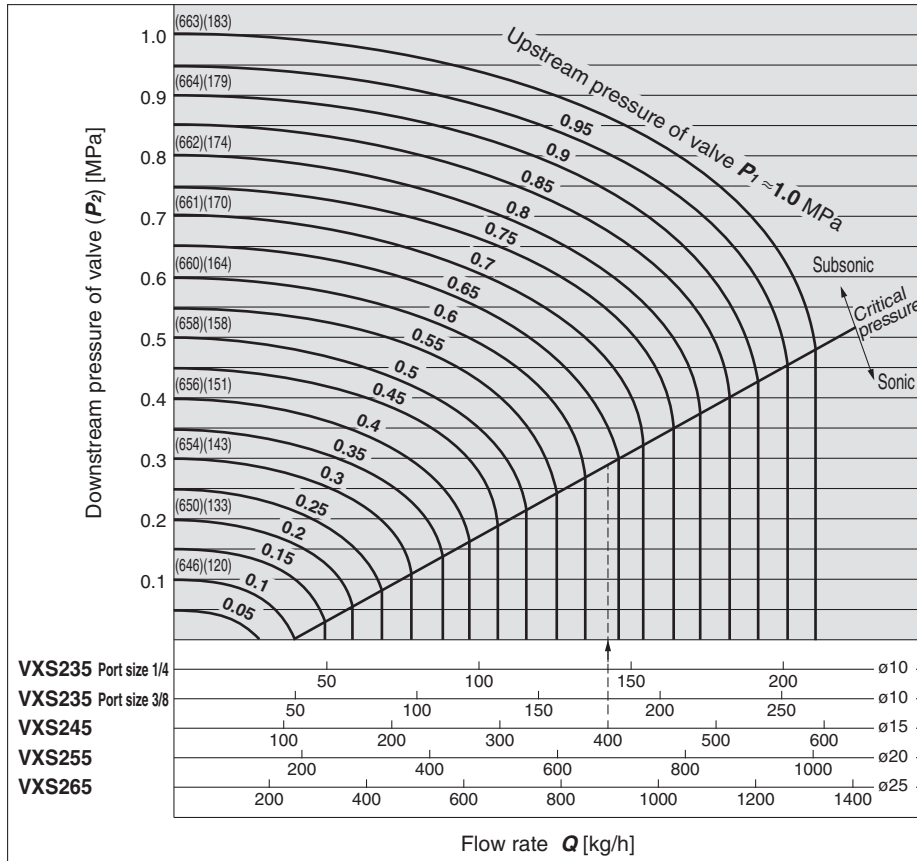

() : Saturated steam holding heat [kcal/kg] () : Saturation temperature [°C]

How to read the graph

The sonic range pressure to generate a flow rate of 400 kg/h is as follows.

For a $\phi 15$ orifice (VXS224□-04),

$P_1 \approx 0.64$ MPa

The holding heat slightly differs depending on the pressure P_1 , but at 400 kg/h it is approx. 25900 kcal/h.

For Water

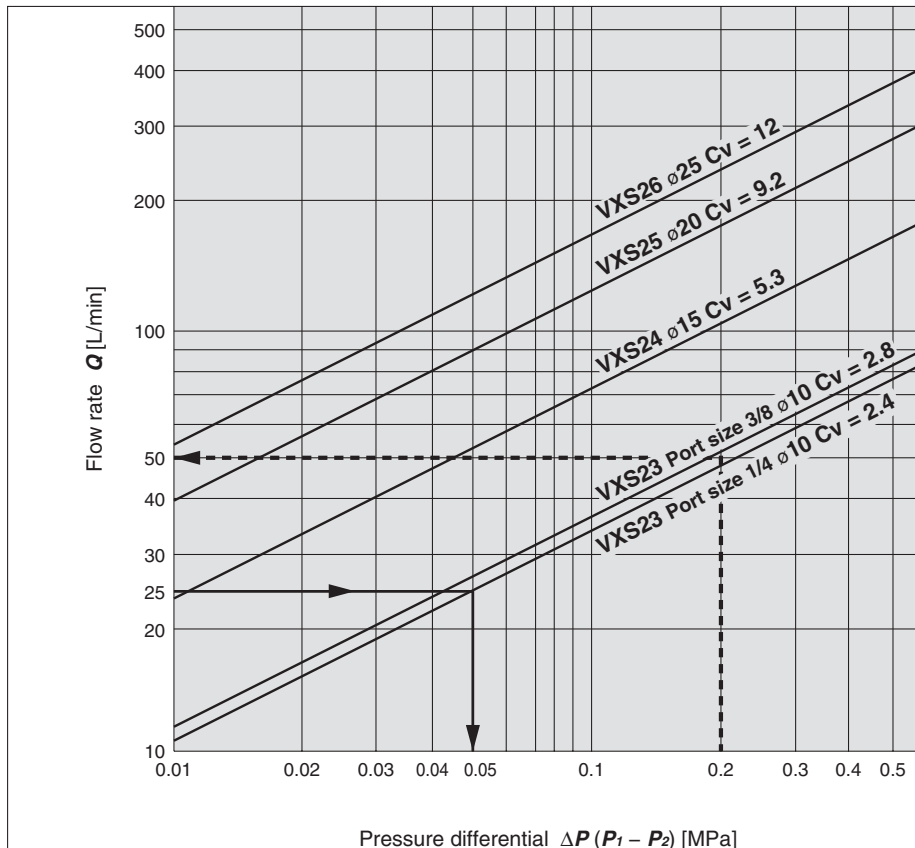

How to read the graph

The pressure differential to generate a flow rate of 25 L/min water is as follows: for a $\phi 10$ orifice (VXS23/Port size 1/4), $\Delta P \approx 0.05$ MPa

The optimum size for a pressure differential of $\Delta P \approx 0.2$ MPa and a flow of 50 L/min will be the VXS23 ($\phi 10$ orifice, port size 3/8).



Series VXS

Specific Product Precautions 1

Be sure to read before handling. Refer to back cover for Safety Instructions, "Handling Precautions for SMC Products" (M-E03-3) and the Operation Manual for 2 Port Solenoid Valves for Fluid Control Precautions. Please download it via our website, <http://www.smcworld.com>

Design

Warning

- 1. Cannot be used as an emergency shutoff valve etc.**

The valves presented in this catalogue are not designed for safety applications such as an emergency shutoff valve. If the valves are used in this type of system, other reliable safety assurance measures should also be adopted.
- 2. Extended periods of continuous energisation**

The solenoid coil will generate heat when continuously energised. Avoid using in a tightly shut container. Install it in a well ventilated area. Furthermore, do not touch it while it is being energised or right after it is energised.
- 3. Liquid rings**

In cases with a flowing liquid, provide a bypass valve in the system to prevent the liquid from entering the liquid seal circuit.
- 4. Pressure holding**

It is not usable for an application such as holding the pressure inside of a pressure vessel because air leakage is entailed in a valve.
- 5. When the conduit type is used as equivalent to an IP65 enclosure, install a wiring conduit etc.**
- 6. When an impact, such as steam hammer etc., caused by the rapid pressure fluctuation is applied, the solenoid valve may be damaged. Give an attention to it.**

Selection

Warning

- 1. Usage with low flow**

Unstable flow may occur with the product under the following conditions: • low flow from the pump or boiler, etc. • use of several elbows or tees in the circuit, or • thin nozzles installed at the end of the piping etc. This can cause valve opening/closing failure, or oscillation, and cause a valve malfunction.

Check the pressure differential and flow to select the appropriate size of the valve referring to the Flow-rate Characteristics on page 12. Ensure that pressure differential does not become lower than 0.01 MPa during ON (N.C.: Valve open).
- 2. Fluid**
 - 1) Corrosive gas**

Cannot be used since it will lead to cracks by stress corrosion or result in other incidents.
 - 2) When a brass body is used, then depending on water quality, corrosion and internal leakage may occur. If such abnormalities occur, exchange the product for a stainless steel body.**
 - 3) Use an oil-free specification when any oily particle must not enter the passage.**

Selection

Warning

- 3. Air quality**

<Steam, Water>

The use of a fluid that contains foreign objects can cause problems such as malfunction and seal failure by promoting wear of the valve seat and armature, and by sticking to the sliding parts of the armature etc. Install a suitable filter (strainer) immediately upstream from the valve. As a general rule, use 100 mesh.

As a standard, the mesh count for the strainer is 100 mesh. However, the size and shape of foreign objects that occur depends on the operating environment. Check the fluid status and choose an appropriate mesh count.

The supply water to a boiler includes materials that create a hard sediment or sludge such as calcium and magnesium.

Sediment and sludge from steam can cause the valve to not operate properly. Install a water softening device, which removes these materials. Do not use operation steam which contains chemicals, synthetic oils containing organic solvents, salts or corrosive gases, etc., as these can cause damage or deterioration.

Since the special FKM used for this product improves the alkali-resistance when compared to the general FKM, it can be used for the steam, into which the boiler compound is charged.

However, the resistance to other chemicals, such as organic solvent is the same as the general FKM. So, use this product after checking the resistance to the components included in the boiler compound.
- 4. Ambient environment**

Use within the operable ambient temperature range. Check the compatibility between the product's composition materials and the ambient atmosphere. Be certain that the fluid used does not touch the external surface of the product.
- 5. Low temperature operation**
 - 1) The valve can be used in an ambient temperature of between -20 to -10°C. However, take measures to prevent freezing or solidification of impurities, etc.**
 - 2) When using valves for water application in cold climates, take appropriate countermeasures to prevent the water from freezing in tubing after cutting the water supply from the pump, by draining the water etc. When warming by a heater etc., be careful not to expose the coil portion to a heater.**

Installation of a dryer, heat retaining of the body is recommended to prevent a freezing condition in which the dew point temperature is high and the ambient temperature is low, and the high flow runs.



Series VXS Specific Product Precautions 2

Be sure to read before handling. Refer to back cover for Safety Instructions, "Handling Precautions for SMC Products" (M-E03-3) and the Operation Manual for 2 Port Solenoid Valves for Fluid Control Precautions. Please download it via our website, <http://www.smcworld.com>

Selection

⚠ Caution

1. Leakage voltage

Particularly when using a resistor in parallel with a switching element and using a C-R element (surge voltage suppressor) to protect the switching element, take note that leakage current will flow through the resistor, C-R element, etc., creating a possible danger that the valve may not turn off.

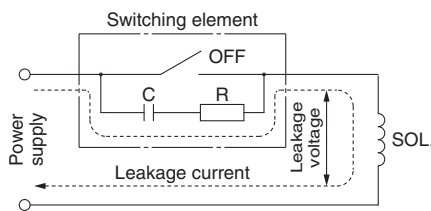

AC coil: 5% or less of rated voltage
DC coil: 2% or less of rated voltage

Mounting

⚠ Warning

1. If air leakage increases or equipment does not operate properly, stop operation.

After mounting is completed, confirm that it has been done correctly by performing a suitable function test.

2. Do not apply external force to the coil section.

When tightening is performed, apply a wrench or other tool to the outside of the piping connection parts.

3. Mount a valve with its coil position upward, not downward.

When mounting a valve with its coil positioned downward, foreign objects in the fluid will adhere to the iron core leading to a malfunction. Especially for strict leakage control, the coil must be positioned upward.

4. Do not warm the coil assembly with a heat insulator etc.

Use tape, heaters, etc., for freeze prevention on the piping and body only. They can cause the coil to burn out.

5. Secure with brackets, except in the case of steel piping and copper fittings.

6. Avoid sources of vibration, or adjust the arm from the body to the minimum length so that resonance will not occur.

7. Painting and coating

Warnings or specifications printed or labelled on the product should not be erased, removed or covered up.

Piping

⚠ Caution

1. Preparation before piping

Before piping is connected, it should be thoroughly blown out with air (flushing) or washed to remove chips, cutting oil and other debris from inside the pipe. Avoid pulling, compressing, or bending the valve body when piping.

2. Avoid connecting ground lines to piping, as this may cause electric corrosion of the system.

3. Always tighten threads with the proper tightening torque.

Refer to the tightening torque in the table below for connecting steel piping. Lower tightening torque will lead into fluid leakage. For mounting the fittings, refer to the specified torque.

Tightening Torque for Piping

Connection thread	Proper tightening torque [N·m]
Rc1/8	3 to 5
Rc1/4	8 to 12
Rc3/8	15 to 20
Rc1/2	20 to 25
Rc3/4	
Rc1	36 to 38

4. Connection of piping to products

When connecting piping to a product, avoid mistakes regarding the supply port etc.

5. Wrapping of sealant tape

When connecting pipes, fittings, etc., be sure that chips from the pipe threads and sealing material do not enter the valve. Furthermore, when sealant tape is used, leave 1.5 to 2 thread ridges exposed at the end of the threads.

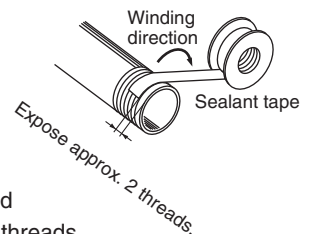

6. If an excessive amount of thread sealant such as sealant tape or liquid thread sealant is used during piping, it will get inside the product and lead to malfunction.

7. Steam generated in a boiler contains a large amount of drainage. Be sure to operate it with a drain trap installed.

8. Arrange piping so that condensate will not accumulate in the solenoid valve.

Install the piping to the solenoid valve higher than peripheral piping. Be sure to avoid installing the piping to the solenoid valve at the lowest part of the piping layout. If condensate accumulates in the solenoid valve or peripheral piping, the steam entering the piping will cause steam hammer. This will lead to destruction and malfunction of the solenoid valve and piping. If steam hammer causes problems, install bypass piping to thoroughly discharge condensate from the piping. Apply steam to the device afterward to start operation.



Series VXS

Specific Product Precautions 3

Be sure to read before handling. Refer to back cover for Safety Instructions, "Handling Precautions for SMC Products" (M-E03-3) and the Operation Manual for 2 Port Solenoid Valves for Fluid Control Precautions. Please download it via our website, <http://www.smcworld.com>

Piping

Caution

9. If the effective area of piping on the fluid supply side is restricted, the operating time may become unstable due to differential pressure fluctuation when the valve is closed.
10. For the convenience of maintenance and repair, install a bypass circuit and use a union for piping.
11. To control the fluid in the tank, connect the piping a little higher than the bottom of the tank.

Wiring

Caution

1. As a rule, use electrical wire with a cross sectional area of 0.5 to 1.25 mm² for wiring. Furthermore, do not allow excessive force to be applied to the lines.
2. Use electrical circuits which do not generate chattering in their contacts.
3. Use voltage which is within $\pm 10\%$ of the rated voltage. In cases with a DC power supply where importance is placed on responsiveness, stay within $\pm 5\%$ of the rated value. The voltage drop is the value in the lead wire section connecting the coil.
4. When a surge from the solenoid affects the electrical circuitry, install a surge voltage suppressor etc., in parallel with the solenoid. Or, adopt an option that comes with the surge voltage protection circuit. (However, a surge voltage occurs even if the surge voltage protection circuit is used. For details, please consult with SMC.)
5. Do not apply AC voltage to AC type unless it is built in full-wave rectifier, or the coil will be damaged.

Operating Environment

Warning

1. Do not use in an atmosphere having corrosive gases, chemicals, sea water, water, water vapor, or where there is direct contact with any of these.
2. Do not use in explosive atmospheres.
3. Do not use in locations subject to vibration or impact.
4. Do not use in locations where radiated heat will be received from nearby heat sources.
5. Employ suitable protective measures in locations where there is contact with water droplets, oil or welding spatter, etc.

Maintenance

Warning

1. Removing the product

The valve will reach a high temperature when used with high temperature fluids. Confirm that the valve temperature has dropped sufficiently before performing work. If touched inadvertently, there is a danger of being burned.

- 1) Shut off the fluid supply and release the fluid pressure in the system.
- 2) Shut off the power supply.
- 3) Dismount the product.

2. Low frequency operation

Switch valves at least once every 30 days to prevent a malfunction. Also, in order to use it under the optimum state, conduct a regular inspection once a half year.

Caution

1. Strainers

- 1) Be careful regarding clogging of strainers.
- 2) Clean strainers when the pressure drop reaches 0.1 MPa.

2. Lubrication

When using after lubricating, never forget to lubricate continuously.

3. Storage

In case of long term storage after use, thoroughly remove all moisture to prevent rust and deterioration of rubber materials etc.

4. Exhaust the drainage from the piping periodically.

Operating Precautions

Warning

1. If there is a possibility of reverse pressure being applied to the valve, take countermeasures such as mounting a check valve on the downstream side of the valve.
2. When problems are caused by a steam hammer, install a steam hammer relief device such as an accumulator.
3. When the pilot type 2 port solenoid valve is closed, and pressure is applied suddenly due to the starting of fluid supply source such as a boiler, the valve may open momentarily and fluid may leak.
4. If the product is used in the conditions in which rapid decrease in the inlet pressure of the valve and rapid increase in the outlet pressure of the valve are repeated, excessive stress will be applied to the piston, which causes the piston to be damaged and dropped, leading to the operation failure of the valve. Check the operating conditions before use.



Series VXS Specific Product Precautions 4

Be sure to read before handling. Refer to back cover for Safety Instructions, "Handling Precautions for SMC Products" (M-E03-3) and the Operation Manual for 2 Port Solenoid Valves for Fluid Control Precautions. Please download it via our website, <http://www.smcworld.com>

Electrical Connections

Caution

Grommet

Class H coil: AWG18 Insulator O.D. 2.1 mm

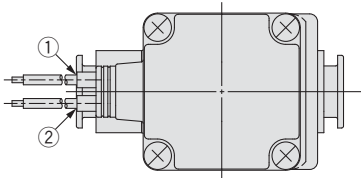

Rated voltage	Lead wire colour	
	①	②
DC	Black	Red
100 VAC	Blue	Blue
200 VAC	Red	Red
Other AC	Grey	Grey

* There is no polarity.

DIN terminal

Since internal connections are as shown below for the DIN terminal, make connections to the power supply accordingly.

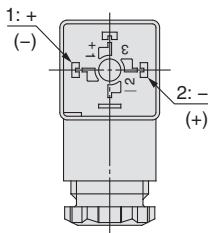

Terminal no.	1	2
DIN terminal	+ (-)	- (+)

* There is no polarity.
· Use a heavy-duty cord with cable O.D. of $\phi 6$ to $\phi 12$ mm.
· Use the tightening torques below for each section.

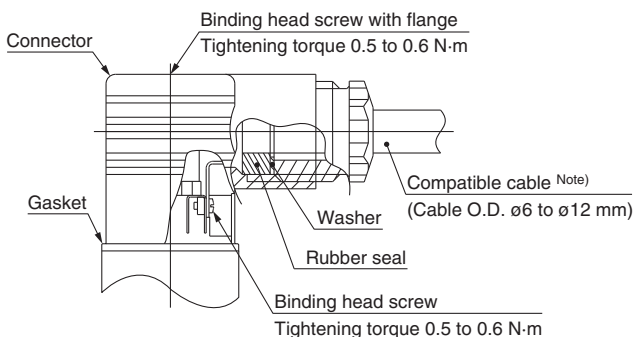

Note) For cable O.D. of $\phi 9$ to $\phi 12$ mm, remove the internal parts of the rubber seal before using.

[Change of electrical entry]

Wire entry can be changed by mounting the housing in either direction (four directions at every 90°) after dividing the terminal block and the housing.

* For the indicator lighted style, be careful not to damage the light with the lead wire of the cable.

Conduit terminal

In the case of the conduit terminal, make connections according to the marks shown below.

- Use the tightening torques below for each section.
- Properly seal the terminal connection (G1/2) with the special wiring conduit etc.

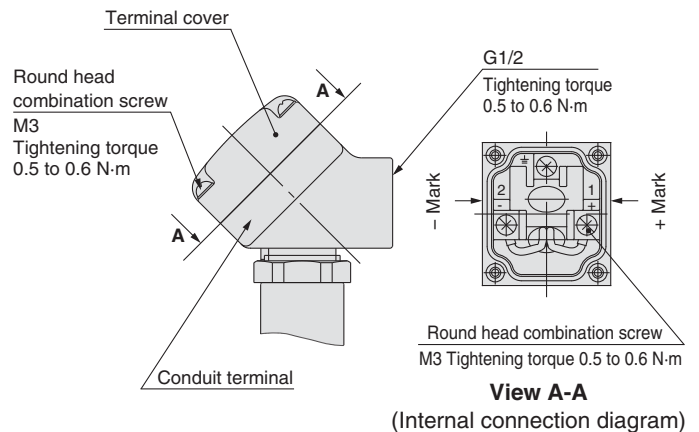

Conduit

When used as an IP65 equivalent, use seal to install the wiring conduit. Also, use the tightening torque below for the conduit.

Class H coil: AWG18 Insulator O.D. 2.1 mm

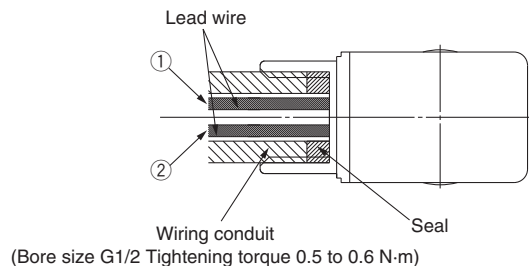

Rated voltage	Lead wire colour	
	①	②
DC	Black	Red
100 VAC	Blue	Blue
200 VAC	Red	Red
Other AC	Grey	Grey

* There is no polarity.
(For the power saving type, there is polarity.)

Description	Part no.
Seal	VCW20-15-6

Note) Please order separately.



Series VXS

Specific Product Precautions 5

Be sure to read before handling. Refer to back cover for Safety Instructions, "Handling Precautions for SMC Products" (M-E03-3) and the Operation Manual for 2 Port Solenoid Valves for Fluid Control Precautions. Please download it via our website, <http://www.smcworld.com>

Electrical Circuits

⚠ Caution

[DC circuit]

Grommet

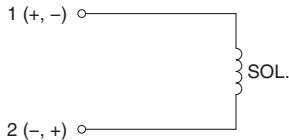

Without electrical option

DIN terminal

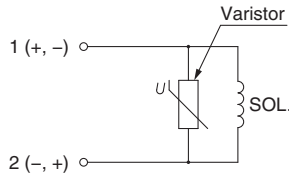

With surge voltage suppressor

DIN terminal, Conduit terminal

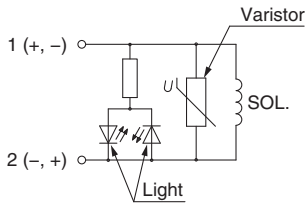

With light/surge voltage suppressor

[AC circuit]

Grommet, DIN terminal,
Conduit terminal, Conduit

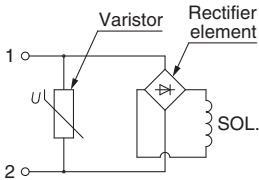

With surge voltage suppressor

DIN terminal, Conduit terminal

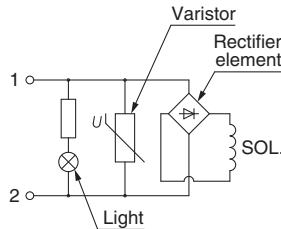



With light/surge voltage suppressor

DIN terminal H type with AC voltage has full-wave rectifier built in the DIN connector. Coil does not have full-wave rectifier.

Safety Instructions

These safety instructions are intended to prevent hazardous situations and/or equipment damage. These instructions indicate the level of potential hazard with the labels of “**Caution**,” “**Warning**” or “**Danger**.” They are all important notes for safety and must be followed in addition to International Standards (ISO/IEC)*1), and other safety regulations.

-  **Caution:** **Caution** indicates a hazard with a low level of risk which, if not avoided, could result in minor or moderate injury.
-  **Warning:** **Warning** indicates a hazard with a medium level of risk which, if not avoided, could result in death or serious injury.
-  **Danger:** **Danger** indicates a hazard with a high level of risk which, if not avoided, will result in death or serious injury.

- *1) ISO 4414: Pneumatic fluid power – General rules relating to systems.
 ISO 4413: Hydraulic fluid power – General rules relating to systems.
 IEC 60204-1: Safety of machinery – Electrical equipment of machines.
 (Part 1: General requirements)
 ISO 10218-1: Manipulating industrial robots - Safety.
 etc.

Warning

- The compatibility of the product is the responsibility of the person who designs the equipment or decides its specifications.**
 Since the product specified here is used under various operating conditions, its compatibility with specific equipment must be decided by the person who designs the equipment or decides its specifications based on necessary analysis and test results. The expected performance and safety assurance of the equipment will be the responsibility of the person who has determined its compatibility with the product. This person should also continuously review all specifications of the product referring to its latest catalogue information, with a view to giving due consideration to any possibility of equipment failure when configuring the equipment.
- Only personnel with appropriate training should operate machinery and equipment.**
 The product specified here may become unsafe if handled incorrectly. The assembly, operation and maintenance of machines or equipment including our products must be performed by an operator who is appropriately trained and experienced.
- Do not service or attempt to remove product and machinery/equipment until safety is confirmed.**
 - The inspection and maintenance of machinery/equipment should only be performed after measures to prevent falling or runaway of the driven objects have been confirmed.
 - When the product is to be removed, confirm that the safety measures as mentioned above are implemented and the power from any appropriate source is cut, and read and understand the specific product precautions of all relevant products carefully.
 - Before machinery/equipment is restarted, take measures to prevent unexpected operation and malfunction.
- Contact SMC beforehand and take special consideration of safety measures if the product is to be used in any of the following conditions.**
 - Conditions and environments outside of the given specifications, or use outdoors or in a place exposed to direct sunlight.
 - Installation on equipment in conjunction with atomic energy, railways, air navigation, space, shipping, vehicles, military, medical treatment, combustion and recreation, or equipment in contact with food and beverages, emergency stop circuits, clutch and brake circuits in press applications, safety equipment or other applications unsuitable for the standard specifications described in the product catalogue.
 - An application which could have negative effects on people, property, or animals requiring special safety analysis.
 - Use in an interlock circuit, which requires the provision of double interlock for possible failure by using a mechanical protective function, and periodical checks to confirm proper operation.

Caution

- The product is provided for use in manufacturing industries.**
 The product herein described is basically provided for peaceful use in manufacturing industries.
 If considering using the product in other industries, consult SMC beforehand and exchange specifications or a contract if necessary.
 If anything is unclear, contact your nearest sales branch.

Limited warranty and Disclaimer/ Compliance Requirements

The product used is subject to the following “Limited warranty and Disclaimer” and “Compliance Requirements”.

Read and accept them before using the product.

Limited warranty and Disclaimer

- The warranty period of the product is 1 year in service or 1.5 years after the product is delivered.*2)
 Also, the product may have specified durability, running distance or replacement parts. Please consult your nearest sales branch.
- For any failure or damage reported within the warranty period which is clearly our responsibility, a replacement product or necessary parts will be provided.
 This limited warranty applies only to our product independently, and not to any other damage incurred due to the failure of the product.
- Prior to using SMC products, please read and understand the warranty terms and disclaimers noted in the specified catalogue for the particular products.

*2) **Vacuum pads are excluded from this 1 year warranty.**

A vacuum pad is a consumable part, so it is warranted for a year after it is delivered. Also, even within the warranty period, the wear of a product due to the use of the vacuum pad or failure due to the deterioration of rubber material are not covered by the limited warranty.

Compliance Requirements

- The use of SMC products with production equipment for the manufacture of weapons of mass destruction (WMD) or any other weapon is strictly prohibited.
- The exports of SMC products or technology from one country to another are governed by the relevant security laws and regulations of the countries involved in the transaction. Prior to the shipment of a SMC product to another country, assure that all local rules governing that export are known and followed.

Safety Instructions

Be sure to read “Handling Precautions for SMC Products” (M-E03-3) before using.

SMC Corporation (Europe)

Austria	☎+43 (0)2262622800	www.smc.at	office@smc.at
Belgium	☎+32 (0)33551464	www.smc-pneumatics.be	info@smc-pneumatics.be
Bulgaria	☎+359 (0)2807670	www.smc.bg	office@smc.bg
Croatia	☎+385 (0)13707288	www.smc.hr	office@smc.hr
Czech Republic	☎+420 541424611	www.smc.cz	office@smc.cz
Denmark	☎+45 70252900	www.smc.dk.com	smc@smcdk.com
Estonia	☎+372 6510370	www.smc-pneumatics.ee	smc@smc-pneumatics.ee
Finland	☎+358 207513513	www.smc.fi	smcffi@smc.fi
France	☎+33 (0)164761000	www.smc-france.fr	promotion@smc-france.fr
Germany	☎+49 (0)61034020	www.smc-pneumatik.de	info@smc-pneumatik.de
Greece	☎+30 210 2717265	www.smchellas.gr	sales@smchellas.gr
Hungary	☎+36 23511390	www.smc.hu	office@smc.hu
Ireland	☎+353 (0)14039000	www.smc-pneumatics.ie	sales@smc-pneumatics.ie
Italy	☎+39 0292711	www.smcitalia.it	mailbox@smcitalia.it
Latvia	☎+371 67817700	www.smc.lv	info@smclv.lv

Lithuania	☎+370 5 2308118	www.smclt.lt	info@smclt.lt
Netherlands	☎+31 (0)205318888	www.smc-pneumatics.nl	info@smc-pneumatics.nl
Norway	☎+47 67129020	www.smc-norge.no	post@smc-norge.no
Poland	☎+48 (0)222119616	www.smc.pl	office@smc.pl
Portugal	☎+351 226166570	www.smc.eu	postpt@smc.smces.es
Romania	☎+40 213205111	www.smcromania.ro	smcromania@smcromania.ro
Russia	☎+7 8127185445	www.smc-pneumatik.ru	info@smc-pneumatik.ru
Slovakia	☎+421 (0)413213212	www.smc.sk	office@smc.sk
Slovenia	☎+386 (0)73885412	www.smc.si	office@smc.si
Spain	☎+34 902184100	www.smc.eu	post@smc.smces.es
Sweden	☎+46 (0)86031200	www.smc.nu	post@smc.nu
Switzerland	☎+41 (0)523963131	www.smc.ch	info@smc.ch
Turkey	☎+90 212 489 0 440	www.smc-pneumatik.com.tr	info@smc-pneumatik.com.tr
UK	☎+44 (0)845 121 5122	www.smc-pneumatics.co.uk	sales@smc-pneumatics.co.uk