

PT. NO.	PARTS NAME	CAT. NO.	MATERIAL	Q'TY	NOTE
1	REEL	_____	POLYSTYRENE	1	_____
2	PLASTIC (EMBOSS) TAPE	_____	PET RESIN OR PP RESIN	_____	COLOR : TRANSPARENCY
3	COVER	_____	POLYESTER	_____	COLOR : TRANSPARENCY
4	CONNECTOR	BTFW_R-3RBTGLF	SEE ATTACHED DWG.	700	

DIMENSIONS

CATALOG NUMBER	NO. OF CONTACT(ONLY EVEN POS.)	A	B	C
BTFW10~14R-3RBTGE4LF	10~14	37.5	32	28.4
BTFW16~24R-3RBTGE4LF	16~24	49.5	44	40.4
BTFW26~30R-3RBTGE4LF	26~30	61.5	56	52.4

- NOTES
1. THIS IS PLASTIC TAPE PACKAGED CONNECTOR USED FOR BOARD TO BOARD CYPES WITH AUTOMATIC MOUNTING (SMT).
 2. SEE JIS C 0806 (PACKING OF ELECTRONIC COMPONENTS ON CONTINUOUS TAPES (SURFACE MOUNTING DEVICES)) FOR SHAPE AND DIMENSIONS OF PLASTIC (EMBOSS) TAPE AND REEL.
 3. THIS DIMENSION IS PORTION OF THE CORE.

mat'l. code		surface ISO 1302 ✓		tolerance ISO 406 ISO 1101		projection		product family 590F	
ltr	ecn no	dr	date	tolerances unless otherwise specified					
A	J10-0042	M.K	Feb.19,'10	angles		linear		title PLASTIC TAPE PACKAGED BOARD TO BOARD RECEPTACLE CONNECTOR (GOLD PLATING, LEAD FREE AND PLASTIC REEL) (CAT.No.BTFW__R-3RBTGE4LF)	
				± 5°		± 5		scale	
		dr	M.Koga	Feb.19,'10	FCJ		dwg no		sheet 1 of 1
		enr	M.Koga	Feb.19,'10			JSA 97490		size A4
		chr	K.Higuchi	Feb.19,'10			type		Product Customer Drawing
		appd	M.Koga	Feb.19,'10					
sheet index	revision sheet								Rev A



FCIconnect.com

Copyright FCI



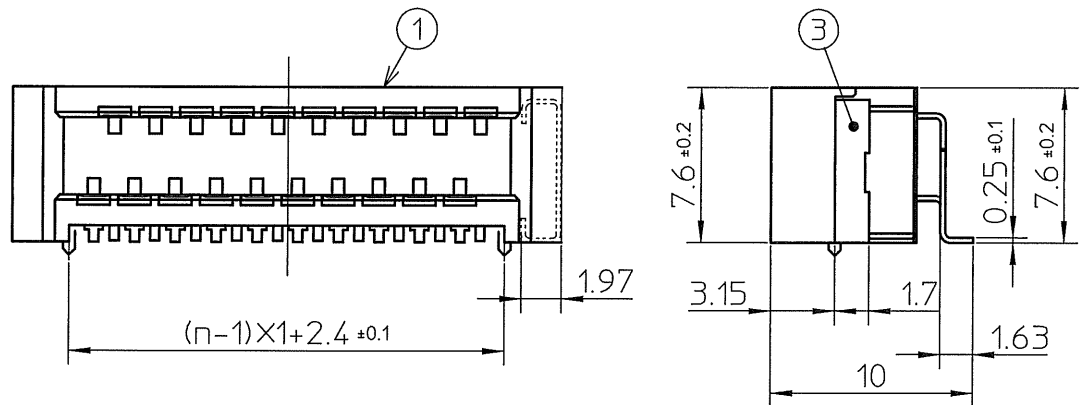
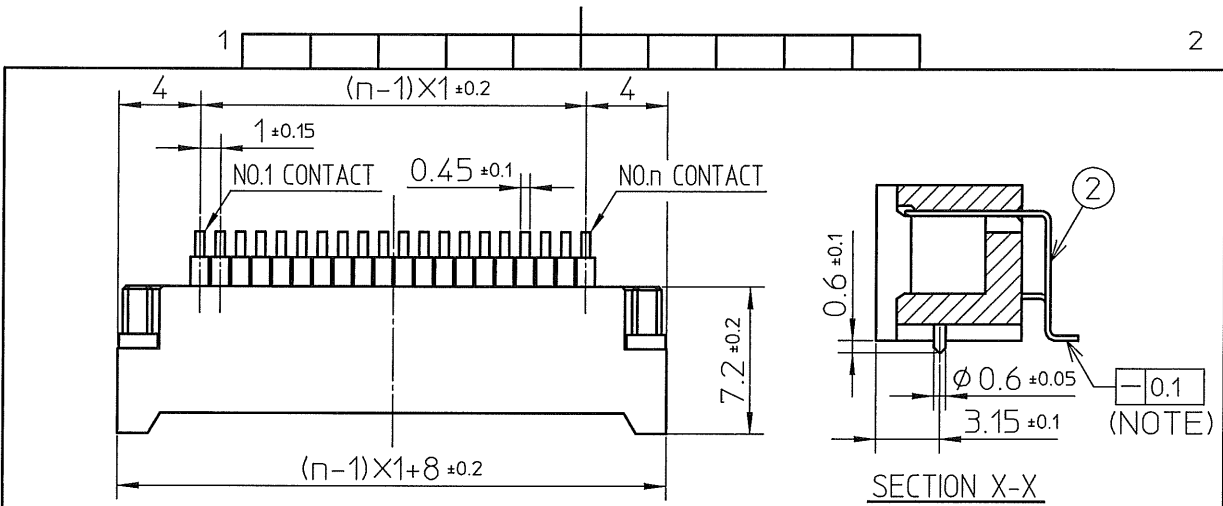

PT. NO.	PARTS NAME	MATERIAL	Q'TY	NOTE
1	HOUSING	GLASS FILLED THERMOPLASTIC RATED,(UL94V-0)	1	COLOR:BRACK
2	CONTACT	BRASS	n	PLATING CONTACT AREA:GOLD OVER NICKL TERMINAL AREA:TIN (LEAD FREE)
3	MOUNTING PLATE	BRASS	2	PLATING:TIN (LEAD FREE)

RECOMMENDED PC BOARD LAYOUT
(COMPONENT SIDE)

n:NO. OF CONTACTS
(10 TO 30 , ONLY EVEN POS.)

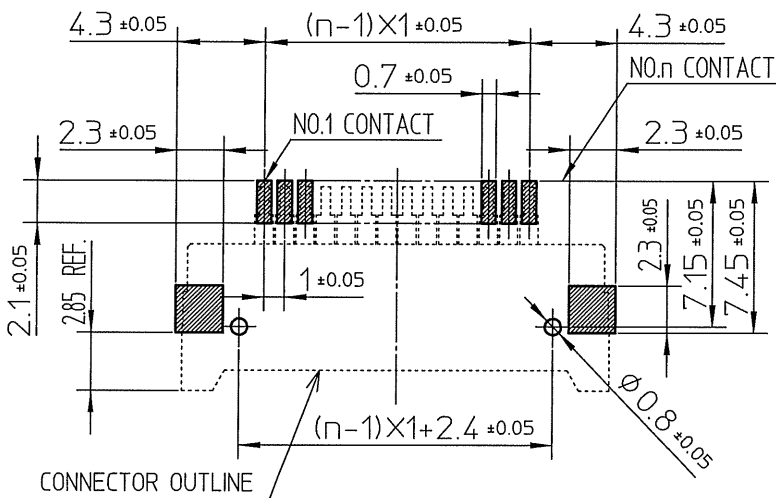

NOTE
1.Flatness for contact terminal and mounting plate must be within 0.1.
2.This product meets European Union Directives and other country regulations as described in GS-22-008.

mat'l. code				surface ISO 1302 ✓		tolerance ISO 406 ISO 1101		projection		product family 590F	
ltr ecn no dr date				tolerances unless otherwise specified				title		FLOATING BOARD TO BOARD RECEPTACLE CONNECTOR (GOLD PLATING AND LEAD FREE) (CAT.No.BTFW__R-3RBTGLF)	
A J10-0042 M.K Feb.19,'10				angles linear ±0.3		scale		dwg no		sheet 1 of 1 size A4	
				dr K.Higuchi Feb.19,'10		FCI		JSA 97491			
				enrg M.Koga Feb.19,'10				type Product Customer Drawing			
				chr K.Higuchi Feb.19,'10							
				appd M.Koga Feb.19,'10							
sheet index		revision sheet								Rev A	



FCIconnect.com

Copyright FCI

