



POWER SUPPLY

- AC 100-240V Wide-range Input
- Width only 48mm
- Efficiency up to 96.3%
- Excellent Partial Load Efficiency
- 20% Output Power Reserves
- Safe Hiccup^{PLUS} Overload Mode
- Easy Fuse Breaking – 3 times nominal current for 12ms
- Active Power Factor Correction (PFC)
- Minimal Inrush Current Surge
- Full Power Between -25°C and +60°C
- DC-OK Relay Contact
- Current Sharing Feature for Parallel Use
- 3 Year Warranty

PRODUCT DESCRIPTION

The Dimension CP-Series are cost optimized power supplies without compromising quality, reliability and performance. The most outstanding features of CP20.481 are the high efficiency, electronic inrush current limitation, active PFC, wide operational temperature range. The small size is achieved by a synchronous rectification, LLC technology and by many further technological design details.

Products of the CP series come with essential functions. The CP20.481 has a power reserve of 20% included, which may even be used continuously at temperatures up to +45°C. Additionally, the device can deliver about 3 times the nominal output current for 12ms which helps to trip fuses on faulty output branches.

High immunity to transients and power surges as well as low electromagnetic emission, a DC-OK relay contact and a large international approval package for a variety of applications makes this unit suitable for nearly every situation.

SHORT-FORM DATA

Output voltage	DC 48V	Nominal
Adjustment range	48 - 56V	Factory setting 48.0V
Output current	12.0 - 10.3A	Below +45°C ambient
	10.0 - 8.6A	At +60°C ambient
	7.5 - 6.5A	At +70°C ambient
	Derate between +45°C and +70°C	
AC Input voltage AC	AC 100-240V	-15%/+10%
Mains frequency	50-60Hz	±6%
Input current AC	4.26 / 2.23A	At 120 / 230Vac
Power factor	0.99 / 0.98	At 120 / 230Vac
Input voltage DC	DC 110-150V ^{±20%}	
Input current DC	4.64A	At 110Vdc
AC Inrush current	typ. 10.0 / 4.5A	at 120 / 230Vac
Efficiency	95.0 / 96.3%	at 120 / 230Vac
Losses	25.1 / 18.4W	at 120 / 230Vac
Hold-up time	typ. 32 / 32ms	at 120 / 230Vac
Temperature range	-25°C to +70°C	operational
Size (WxHxD)	48x124x127mm	Without DIN-rail
Weight	830g / 1.83lb	

ORDER NUMBERS

Power Supply **CP20.481**

Mechanical Accessory
ZM10.Wall Wall/Panel mount bracket

MAIN APPROVALS

For a complete list of approvals see section 19.



INDEX

	Page		Page
1. Intended Use	3	19. Approvals.....	18
2. Installation Instructions	3	20. Other Fulfilled Standards.....	18
3. AC-Input.....	4	21. Physical Dimensions and Weight.....	20
4. DC-Input.....	5	22. Accessories	21
5. Input Inrush Current	6	22.1. ZM10.WALL – Wall/Panel Mount Bracket	21
6. Output	7	22.2. UF20.481 Buffer Module	22
7. Hold-up Time.....	9	22.3. YR40.482 - Redundancy Module.....	22
8. DC-OK Relay Contact	9	23. Application Notes.....	23
9. Efficiency and Power Losses.....	10	23.1. Peak Current Capability	23
10. Functional Diagram.....	11	23.2. Output Circuit Breakers.....	24
11. Front Side and User Elements.....	11	23.3. Charging of Batteries	25
12. Connection Terminals	12	23.4. Series Operation	25
13. Lifetime Expectancy	13	23.5. Parallel Use to Increase Output Power....	26
14. MTBF	13	23.6. Parallel Use for Redundancy	27
15. EMC.....	14	23.7. Operation on Two Phases	28
16. Environment.....	15	23.8. Use in a Tightly Sealed Enclosure	28
17. Safety and Protection Features	16	23.9. Mounting Orientations	29
18. Dielectric Strength	17		

The information given in this document is correct to the best of our knowledge and experience at the time of publication. If not expressly agreed otherwise, this information does not represent a warranty in the legal sense of the word. As the state of our knowledge and experience is constantly changing, the information in this data sheet is subject to revision. We therefore kindly ask you to always use the latest issue of this document (available under www.pulspower.com).

No part of this document may be reproduced or utilized in any form without our prior permission in writing.

Packaging and packaging aids can and should always be recycled. The product itself may not be disposed of as domestic refuse.

TERMINOLOGY AND ABBREVIATIONS

PE and \oplus symbol	PE is the abbreviation for Protective Earth and has the same meaning as the symbol \oplus .
Earth, Ground	This document uses the term "earth" which is the same as the U.S. term "ground".
T.b.d.	To be defined, value or description will follow later.
AC 230V	A figure displayed with the AC or DC before the value represents a nominal voltage with standard tolerances (usually $\pm 15\%$) included. E.g.: DC 12V describes a 12V battery disregarding whether it is full (13.7V) or flat (10V)
230Vac	A figure with the unit (Vac) at the end is a momentary figure without any additional tolerances included.
50Hz vs. 60Hz	As long as not otherwise stated, AC 230V parameters are valid at 50Hz mains frequency.
may	A key word indicating flexibility of choice with no implied preference.
shall	A key word indicating a mandatory requirement.
should	A key word indicating flexibility of choice with a strongly preferred implementation.

1. INTENDED USE

This device is designed for installation in an enclosure and is intended for commercial use, such as in industrial control, process control, monitoring and measurement equipment or the like.

Do not use this device in equipment where malfunction may cause severe personal injury or threaten human life.

2. INSTALLATION INSTRUCTIONS

⚠ WARNING Risk of electrical shock, fire, personal injury or death.

- Turn power off before working on the device. Protect against inadvertent re-powering.
- Do not modify or repair the unit.
- Do not open the unit as high voltages are present inside.
- Use caution to prevent any foreign objects from entering the housing.
- Do not use in wet locations or in areas where moisture or condensation can be expected.
- Do not touch during power-on, and immediately after power-off. Hot surfaces may cause burns.

Obey the following installation instructions:

This device may only be installed and put into operation by qualified personnel.

This device does not contain serviceable parts. The tripping of an internal fuse is caused by an internal defect.

If damage or malfunction should occur during installation or operation, immediately turn power off and send unit to the factory for inspection.

Install the device in an enclosure providing protection against electrical, mechanical and fire hazards.

Install the device onto a DIN-rail according to EN 60715 with the input terminals on the bottom of the device. Other mounting orientations require a reduction in output current.

Make sure that the wiring is correct by following all local and national codes. Use appropriate copper cables that are designed for a minimum operating temperature of 60°C for ambient temperatures up to +45°C, 75°C for ambient temperatures up to +60°C and 90°C for ambient temperatures up to +70°C. Ensure that all strands of a stranded wire enter the terminal connection.

Unused screw terminals should be securely tightened.

The device is designed for pollution degree 2 areas in controlled environments. No condensation or frost is allowed.

The enclosure of the device provides a degree of protection of IP20.

The isolation of the device is designed to withstand impulse voltages of overvoltage category III according to IEC 60664-1. Above 2000m the overvoltage category is reduced to level II.

The device is designed as "Class of Protection I" equipment according to IEC 61140.

Do not use without a proper PE (Protective Earth) connection. Use the terminal on the input block for earth connection and not one of the screws on the housing.

The device is suitable to be supplied from TN-, TT- and IT mains networks. The voltage between the L or N terminal and the PE terminal must not exceed 300Vac continuously.

The input can also be powered from batteries or similar DC sources. The voltage between the input terminal and the PE terminal must not exceed 375Vdc continuously.

A disconnecting means shall be provided for the input of the device.

The device is designed for convection cooling and does not require an external fan. Do not obstruct airflow and do not cover ventilation grid!

The device is designed for altitudes up to 6000m (19685ft). See additional requirements in this document for use above 2000m (6560ft).

Keep the following minimum installation clearances: 40mm on top, 20mm on the bottom, 5mm left and right side. Increase the 5mm to 15mm in case the adjacent device is a heat source. When the device is permanently loaded with less than 50%, the 5mm can be reduced to zero.

The device is designed, tested and approved for branch circuits up to 32A (IEC) and 30A (UL) without additional protection device. If an external fuse is utilized, do not use circuit breakers smaller than 10A B- or C-Characteristic to avoid a nuisance tripping of the circuit breaker.

The maximum surrounding air temperature is +70°C (+158°F). The operational temperature is the same as the ambient or surrounding air temperature and is defined 2cm below the device.

The device is designed to operate in areas between 5% and 95% relative humidity.

3. AC-INPUT

The device is suitable to be supplied from TN-, TT- and IT mains networks with AC voltage. For suitable DC supply voltages see chapter 4.

AC input	nom.	AC 100-240V	
AC input range		85-264Vac	Continuous operation
		264-300Vac	Occasionally for maximal 500ms
Allowed voltage L or N to earth	max.	300Vac	Continuous, according to IEC 60664-1
Input frequency	nom.	50–60Hz	±6%
Turn-on voltage	typ.	82Vac	Steady-state value, see Fig. 3-1
Shut-down voltage	typ.	72Vac	Steady-state value, see Fig. 3-1
External input protection	See recommendations in chapter 2.		

		AC 100V	AC 120V	AC 230V	
Input current	typ.	5.15A	4.26A	2.23A	At 48V, 10A, see Fig. 3-3
Power factor	typ.	0.996	0.996	0.980	At 48V, 10A, see Fig. 3-4
Crest factor	typ.	1.65	1.63	1.63	At 48V, 10A, The crest factor is the mathematical ratio of the peak value to RMS value of the input current waveform.
Start-up delay	typ.	450ms	450ms	450ms	See Fig. 3-2
Rise time	typ.	120ms	120ms	120ms	At 48V, 10A const. current load, 0mF load capacitance, see Fig. 3-2
	typ.	170ms	170ms	170ms	At 48V, 10A const. current load, 10mF load capacitance, see Fig. 3-2
Turn-on overshoot	max.	500mV	500mV	500mV	In single use mode, see Fig. 3-2

Fig. 3-1 Input voltage range

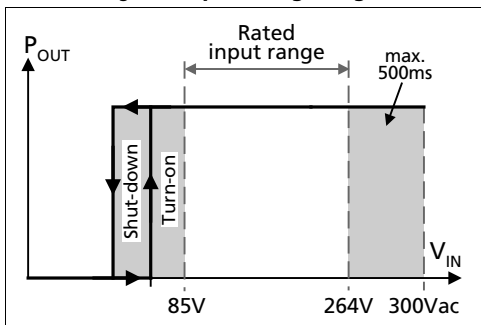

Fig. 3-3 Input current vs. output current at 48V output voltage

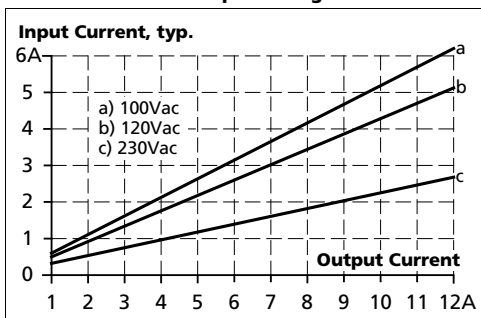

Fig. 3-2 Turn-on behavior, definitions

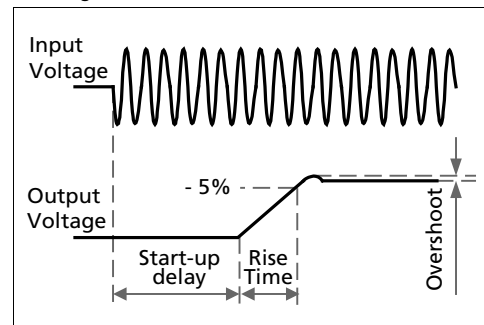
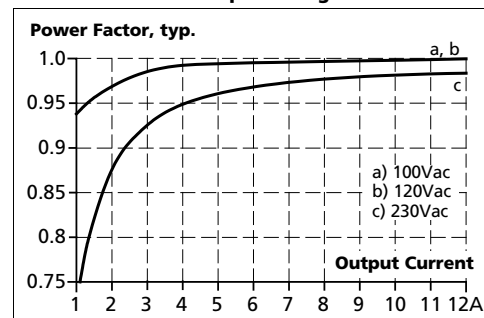

Fig. 3-4 Power factor vs. output current at 48V output voltage



Nov. 2020 / Rev. 1.1a DS-CP20.481-EN All parameters are specified at 230Vac, 50Hz input voltage, 48V, 10A output load, 25°C ambient and after a 5 minutes run-in time unless otherwise noted.

4. DC-INPUT

The device is suitable to be supplied from a DC input voltage. Use a battery or a similar DC source. A supply from the intermediate DC-bus of a frequency converter is not recommended and can cause a malfunction or damage the unit. Connect +pole to L, -pole to N and the PE terminal to an earth wire or to the machine ground.

DC input	Nom.	DC 110-150V	±20%
DC input range		88-180Vdc	Continuous operation
DC input current	typ.	4.64A	At 110Vdc, at 24V, 20A
Allowed Voltage (+) or (-) input to Earth	max.	375Vdc	Continuous according to IEC 60664-1
Turn-on voltage	typ.	80Vdc	Steady state value
Shut-down voltage	typ.	70Vdc	Steady state value

Fig. 4-1 **Wiring for DC Input**

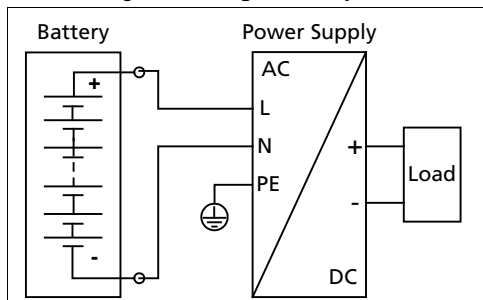

5. INPUT INRUSH CURRENT

An active inrush limitation circuit limits the input inrush current after turn-on of the input voltage. The charging current into EMI suppression capacitors is disregarded in the first microseconds after switch-on.

		AC 100V	AC 120V	AC 230V	
Inrush current	max.	15A _{peak}	12A _{peak}	5.5A _{peak}	Temperature independent
	typ.	12A _{peak}	10A _{peak}	4.5A _{peak}	Temperature independent
Inrush energy	max.	1A ² s	1A ² s	1A ² s	Temperature independent

Fig. 5-1 **Typical input inrush current behaviour at nominal load and 25°C ambient**

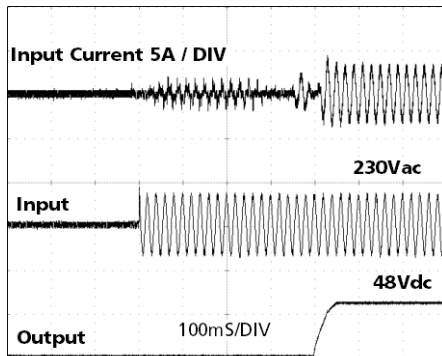

6. OUTPUT

The output provides a SELV/PELV rated voltage, which is galvanically isolated from the input voltage. The device is designed to supply any kind of loads, including capacitive and inductive loads. If extreme large capacitors, such as EDLCs (electric double layer capacitors or "UltraCaps") with a capacitance > 0.25F are connected to the output, the unit might charge the capacitor in an intermittent mode. The output is electronically protected against overload, no-load and short-circuits. In case of a protection event, audible noise may occur.

Output voltage	nom.	48V	
Adjustment range	min.	48-56V	Guaranteed value This is the maximum output voltage which can occur at the clockwise end position of the potentiometer due to tolerances. It is not a guaranteed value which can be achieved.
	max.	60V	
Factory setting output voltage	typ.	48.0V	±0.2% in "single use" mode at full load, cold unit ±0.2% in "parallel use" mode at 10A, cold unit (results to 46.6V ±0.2% at 12A and 49.0V ±0.2% at no load)
	typ.	47.0V	
Line regulation	Max.	10mV	Between 85 and 300Vac input voltage change
Load regulation	Max.	150mV	Between 0 and 10A in "single use" mode, static value
	Typ.	2000mV	Between 0 and 10A in "parallel use" mode, static value, see Fig. 6-2
Ripple and noise voltage	max.	50mVpp	Bandwidth 20Hz to 20MHz, 50Ohm
Output current	nom.	12A ¹⁾	At 48V and an ambient temperature below 45°C
	nom.	10A	At 48V and 60°C ambient temperature
	nom.	7.5A	At 48V and 70°C ambient temperature
	nom.	10.3A ¹⁾	At 56V and an ambient temperature below 45°C
	nom.	8.6A	At 56V and 60°C ambient temperature
	Nom.	6.5A	At 56V and 70°C ambient temperature
		Derate linearly between +45°C and +70°C	
Fuse breaking current	typ.	30A	Up to 12ms once every five seconds, see Fig. 6-4. The fuse braking current is an enhanced transient current which helps to trip fuses on faulty output branches. The output voltage stays above 40V.
Overload behavior	Continuous current		For output voltage above 26Vdc, see Fig. 6-1
	Intermittent current ²⁾		For output voltage below 26Vdc, see Fig. 6-1
Overload/ short-circuit current	max.	14.8A	Continuous current, see Fig. 6-1 Intermitted current peak value for typ. 2s Load impedance 10mOhm, see Fig. 6-3 Discharge current of output capacitors is not included.
	typ.	15A	
	max.	4.7A	
Output capacitance	typ.	2 500µF	Included inside the power supply
Back-feeding loads	max.	63V	The unit is resistant and does not show malfunctioning when a load feeds back voltage to the power supply. It does not matter whether the power supply is on or off. The absorbing energy can be calculated according to the built-in large sized output capacitor.

1) This current is also available for temperatures up to +70°C with a duty cycle of 10% and/ or not longer than 1 minute every 10 minutes.

2) At heavy overloads (when output voltage falls below 26V), the power supply delivers continuous output current for 2s. After this, the output is switched off for approx. 18s before a new start attempt is automatically performed. This cycle is repeated as long as the overload exists. If the overload has been cleared, the device will operate normally. See Fig. 6-3.

Fig. 6-1 Output voltage vs. output current, typ.

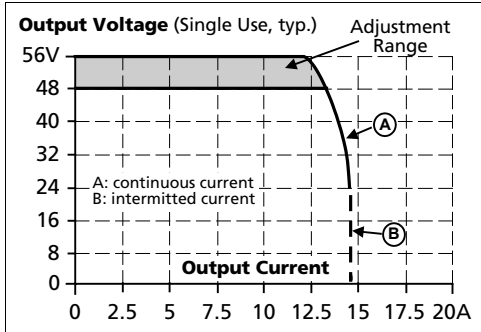

Fig. 6-2 Output voltage in "parallel use" mode, typ.

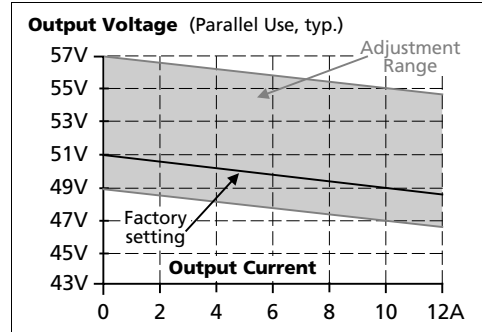

Fig. 6-3 Short-circuit on output, Hiccup^{PLUS} mode, typ.

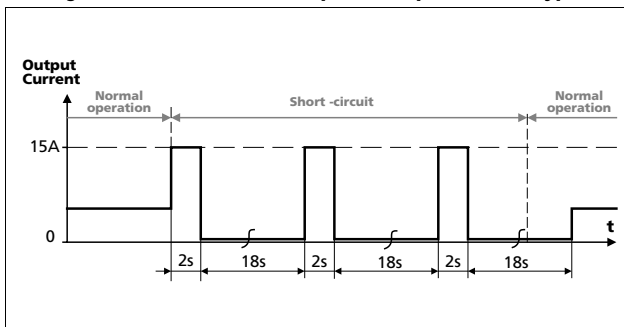
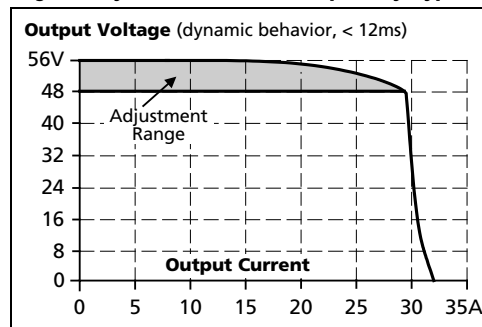

Fig. 6-4 Dynamic overcurrent capability, typ.



7. HOLD-UP TIME

The hold-up time is the time during which a power supply's output voltage remains within specification following the loss of input power. The hold-up time is output load dependent. At no load, the hold-up time can be up to several seconds. The green DC-ok lamp is also on during this time.

		AC 100V	AC 120V	AC 230V	
Hold-up Time	typ.	65ms	65ms	65ms	At 48V, 5A, see Fig. 7-1
	min.	54ms	54ms	54ms	At 48V, 5A, see Fig. 7-1
	typ.	32ms	32ms	32ms	At 48V, 10A, see Fig. 7-1
	min.	24ms	24ms	24ms	At 48V, 10A, see Fig. 7-1

Fig. 7-1 Hold-up time vs. input voltage

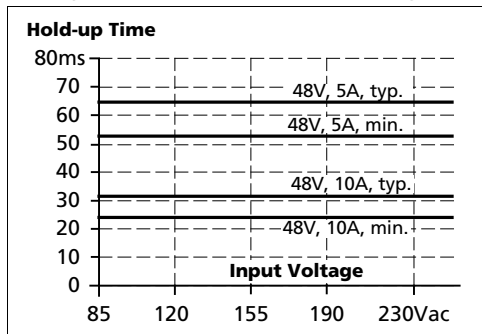
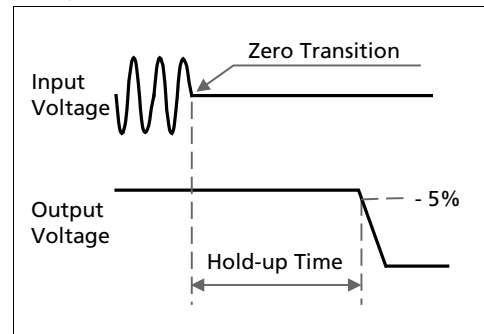

Fig. 7-2 Shut-down behavior, definitions



8. DC-OK RELAY CONTACT

This feature monitors the output voltage on the output terminals of a running power supply.

Contact closes	As soon as the output voltage reaches typ. 90% of the adjusted output voltage level.
Contact opens	As soon as the output voltage dips more than 10% below the adjusted output voltage. Short dips will be extended to a signal length of 100ms. Dips shorter than 1ms will be ignored.
Switching hysteresis	2V
Contact ratings	Maximal 60Vdc 0.3A, 30Vdc 1A, 30Vac 0.5A, resistive load Minimal permissible load: 1mA at 5Vdc
Isolation voltage	See dielectric strength table in section 18.

Fig. 8-1 DC-ok relay contact behavior

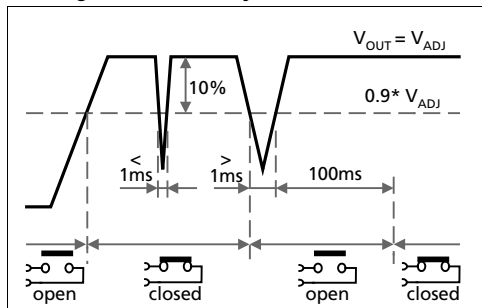

9. EFFICIENCY AND POWER LOSSES

		AC 100V	AC 120V	AC 230V	
Efficiency	typ.	94.4%	95.0%	96.3%	At 48V, 10A
	typ.	94.2%	94.9%	96.2%	At 48V, 12A (Power Boost)
Average efficiency*)	typ.	94.1%	94.6%	95.5%	25% at 2.5A, 25% at 5A, 25% at 7.5A. 25% at 10A
Power losses	typ.	2.7W	2.4W	2.4W	At 48V, 0A
	typ.	14.2W	12.5W	10.6W	At 48V, 5A
	typ.	28.5W	25.1W	18.4W	At 48V, 10A
	typ.	35.4W	31.0W	22.7W	At 48V, 12A (Power Boost)

*) The average efficiency is an assumption for a typical application where the power supply is loaded with 25% of the nominal load for 25% of the time, 50% of the nominal load for another 25% of the time, 75% of the nominal load for another 25% of the time and with 100% of the nominal load for the rest of the time.

Fig. 9-1 **Efficiency vs. output current at 48V, typ.**

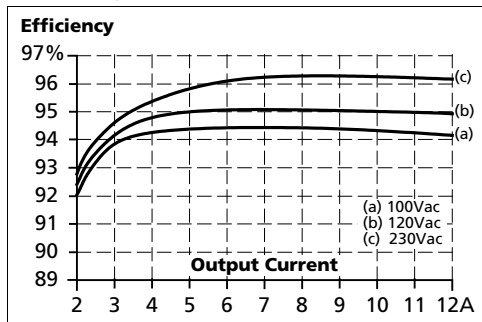

Fig. 9-2 **Losses vs. output current at 48V, typ.**

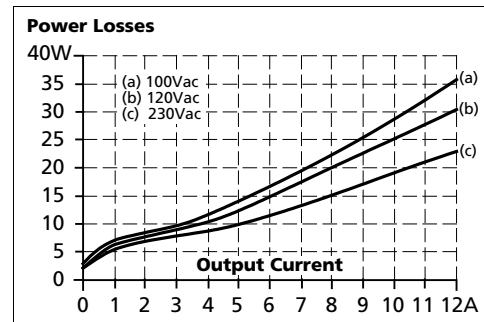

Fig. 9-3 **Efficiency vs. input voltage at 48V, 10A, typ.**

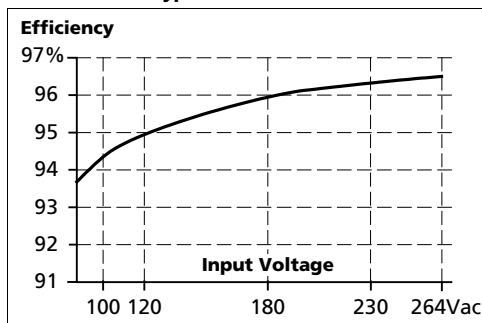
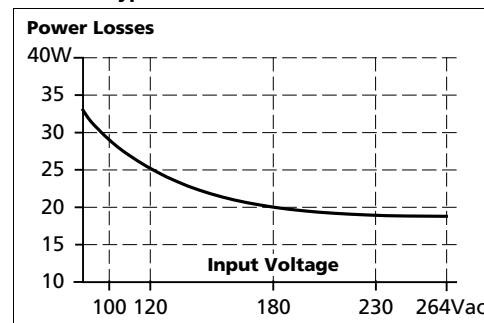
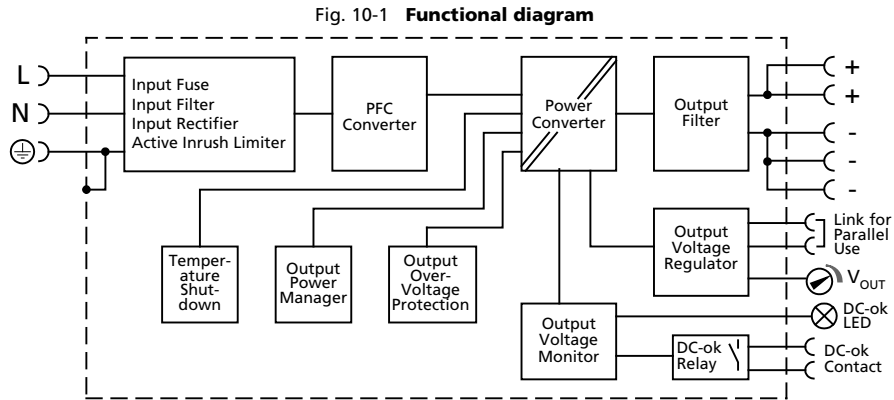

Fig. 9-4 **Losses vs. input voltage at 48V, 10A, typ.**



10. FUNCTIONAL DIAGRAM



11. FRONT SIDE AND USER ELEMENTS

Fig. 11-1 Front side

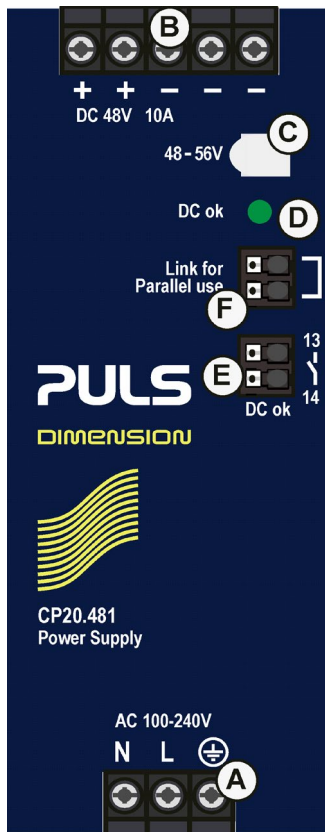

A Input Terminals

- N, L Line input
- ⊕ PE (Protective Earth) input

B Output Terminals

- + Positive output (two identical + poles)
- Negative/ return output (three identical - poles)

C Output voltage potentiometer

Open the flap to adjust the output voltage. The factory setting is 48.0V

D DC-OK LED (green)

On, when the output voltage is >90% of the adjusted output voltage

E DC-OK Relay Contact

The DC-OK relay contact is synchronized with the DC-OK LED. See chapter 8 for details.

F "Parallel Use" "Single Use" link

Link the two terminal poles when power supplies are connected in parallel to increase the output power. In order to achieve a sharing of the load current between the individual power supplies, the "parallel use" regulates the output voltage in such a manner that the voltage at no load is approx. 4% higher than at nominal load. See also chapter 23.5.

12. CONNECTION TERMINALS

The terminals are IP20 Finger safe constructed and suitable for field- and factory wiring.

	Input	Output	Signal Terminals
Type	Screw termination	Screw termination	Push-in termination
Solid wire	max. 6mm ²	max. 6mm ²	max. 1.5mm ²
Stranded wire	max. 4mm ²	max. 4mm ²	max. 1.5mm ²
American Wire Gauge	AWG 20-10	AWG 20-10	AWG 24-16
Max. wire diameter (including ferrules)	2.8mm	2.8mm	1.6mm
Recommended tightening torque	1Nm, 9lb-in	1Nm, 9lb-in	-
Wire stripping length	7mm / 0.28inch	7mm / 0.28inch	7mm / 0.28inch
Screwdriver	3.5mm slotted or cross-head No 2	3.5mm slotted or cross-head No 2	3mm slotted to open the spring

Daisy chaining:

Daisy chaining (jumping from one power supply output to the next) is allowed as long as the average output current through one terminal pin does not exceed 25A. If the current is higher, use a separate distribution terminal block as shown in Fig. 12-2.

Fig. 12-1 Daisy chaining of outputs

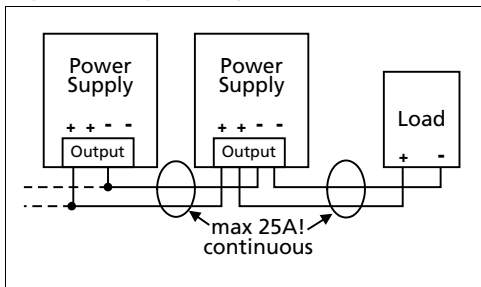
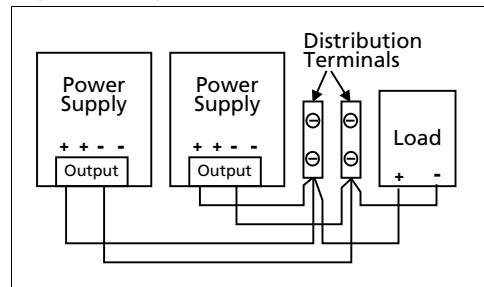

Fig. 12-2 Using distribution terminals



13. LIFETIME EXPECTANCY

The Lifetime expectancy shown in the table indicates the minimum operating hours (service life) and is determined by the lifetime expectancy of the built-in electrolytic capacitors. Lifetime expectancy is specified in operational hours and is calculated according to the capacitor's manufacturer specification. The manufacturer of the electrolytic capacitors only guarantees a maximum life of up to 15 years (131 400h). Any number exceeding this value is a calculated theoretical lifetime which can be used to compare devices.

	AC 100V	AC 120V	AC 230V	
Lifetime expectancy	52 000h	66 000h	110 000h	At 48V, 10A and 40°C
	130 000h	152 000h	180 000h	At 48V, 5A and 40°C
	33 000h	45 000h	8 9 000h	At 48V, 12A and 40°C
	148 000h	188 000h	311 000h	At 48V, 10A and 25°C
	368 000h	431 000h	509 000h	At 48V, 5A and 25°C
	93 000h	128 000h	251 000h	At 48V, 12A and 25°C

14. MTBF

MTBF stands for **Mean Time Between Failure**, which is calculated according to statistical device failures, and indicates reliability of a device. It is the statistical representation of the likelihood of a unit to fail and does not necessarily represent the life of a product.

The MTBF figure is a statistical representation of the likelihood of a device to fail. A MTBF figure of e.g. 1 000 000h means that statistically one unit will fail every 100 hours if 10 000 units are installed in the field. However, it cannot be determined if the failed unit has been running for 50 000h or only for 100h.

For these types of units the MTTF (**Mean Time To Failure**) value is the same value as the MTBF value.

	AC 100V	AC 120V	AC 230V	
MTBF SN 29500, IEC 61709	430 000h	443 000h	540 000h	At 48V, 10A and 40°C
	790 000h	810 000h	973 000h	At 48V, 10A and 25°C
MTBF MIL HDBK 217F	207 000h	209 000h	244 000h	At 48V, 10A and 40°C; Ground Benign GB40
	279 000h	283 000h	334 000h	At 48V, 10A and 25°C; Ground Benign GB25
	44 000h	45 000h	54 000h	At 48V, 10A and 40°C; Ground Fixed GF40
	58 000h	59 000h	72 000h	At 48V, 10A and 25°C; Ground Fixed GF25

15. EMC

The EMC behavior of the device is designed for applications in industrial environment as well as in residential, commercial and light industry environments.

The device is investigated according to EN 61000-6-1, EN 61000-6-2, EN 61000-6-3 and EN 61000-6-4.

Without additional measures to reduce the conducted emissions on the output (e.g. by using a filter), the device is not suited to supply a local DC power network in residential, commercial and light-industrial environments. No restrictions apply for local DC power networks in industrial environments.

EMC Immunity

Electrostatic discharge	EN 61000-4-2	Contact discharge Air discharge	8kV 15kV	Criterion A Criterion A
Electromagnetic RF field	EN 61000-4-3	80MHz-2.7GHz	20V/m	Criterion A
Fast transients (Burst)	EN 61000-4-4	Input lines	4kV	Criterion A
		Output lines	2kV	Criterion A
		DC-OK signal (coupling clamp)	2kV	Criterion A
Surge voltage on input	EN 61000-4-5	L → N	2kV	Criterion A
		L → PE, N → PE	4kV	Criterion A
Surge voltage on output	EN 61000-4-5	+ → -	1kV	Criterion A
		+ / - → PE	2kV	Criterion A
Surge voltage on DC-OK	EN 61000-4-5	DC-OK signal → PE	1kV	Criterion A
Conducted disturbance	EN 61000-4-6	0.15-80MHz	20V	Criterion A
Mains voltage dips	EN 61000-4-11	0% of 100Vac	0Vac, 20ms	Criterion A
		40% of 100Vac	40Vac, 200ms	Criterion C
		70% of 100Vac	70Vac, 500ms	Criterion A
		0% of 200Vac	0Vac, 20ms	Criterion A
		40% of 200Vac	80Vac, 200ms	Criterion A
		70% of 200Vac	140Vac, 500ms	Criterion A
Voltage interruptions	EN 61000-4-11	0% of 200Vac (=0V)	5000ms	Criterion C
Powerful transients	VDE 0160	Over entire load range	750V, 0.3ms	Criterion A

Performance criterions:

A: The device shows normal operation behavior within the defined limits.

C: Temporary loss of function is possible. The device may shut down and restarts by itself. No damage or hazards for the device will occur.

EMC Emission

Conducted emission input lines	EN 55011, EN 55022, FCC Part 15, CISPR 11, CISPR 22	Class B
Radiated emission	EN 55011, EN 55022	Class B
Harmonic input current	EN 61000-3-2	Fulfilled for Class A equipment Fulfilled for Class C equipment in the load range from 4 to 12A
Voltage fluctuations, flicker	EN 61000-3-3	Fulfilled, tested with constant current loads, no pulsing

This device complies with FCC Part 15 rules.

Operation is subjected to following two conditions: (1) this device may not cause harmful interference, and (2) this device must accept any interference received, including interference that may cause undesired operation.

Switching Frequencies

PFC converter	100kHz	Fixed frequency
Main converter	80kHz to 140kHz	Output load dependent
Auxiliary converter	60kHz	Fixed frequency

16. ENVIRONMENT

Operational temperature	-25°C to +70°C (-13°F to 158°F)	The operational temperature is the ambient or surrounding temperature and is defined as the air temperature 2cm below the device.
Storage temperature	-40°C to +85°C (-40°F to 185°F)	For storage and transportation
Output de-rating	6.4W/°C 12W/°C 0.66A/1000m or 5°C/1000m The de-rating is not hardware controlled. The user has to take care by himself to stay below the de-rated current limits in order not to overload the unit.	Between +45°C and +60°C (113°F to 140°F) Between +60°C and +70°C (140°F to 158°F) For altitudes >2000m (6560ft), see Fig. 16-2
Humidity	5 to 95% r.h.	According to IEC 60068-2-30
Atmospheric pressure	110-47kPa	See Fig. 16-2 for details
Altitude	Up to 6000m (19685ft)	See Fig. 16-2 for details
Over-voltage category	III II	According to IEC 60664-1 for altitudes up to 2000m According to IEC 60664-1, for altitudes above 2000m
Degree of pollution	2	According to IEC 62477-1, not conductive
Vibration sinusoidal	2-17.8Hz: ±1.6mm 17.8-500Hz: 2g 2 hours / axis	According to IEC 60068-2-6
Shock	30g 6ms, 20g 11ms 3 bumps / direction 18 bumps in total Shock and vibration is tested in combination with DIN-Rails according to EN 60715 with a height of 15mm and a thickness of 1.3mm and standard orientation.	According to IEC 60068-2-27
LABS compatibility	As a rule, only non-silicon precipitating materials are used. The unit conforms to the LABS criteria and is suitable for use in paint shops.	
Corrosive gases	Tested according to ISA-71.04-1985, Severity Level G3 and IEC 60068-2-60 Test Ke Method 4 for a service life of minimum 10years in these environments.	
Audible noise	Some audible noise may be emitted from the power supply during no load, overload or short circuit.	

Fig. 16-1 Output current vs. ambient temp.

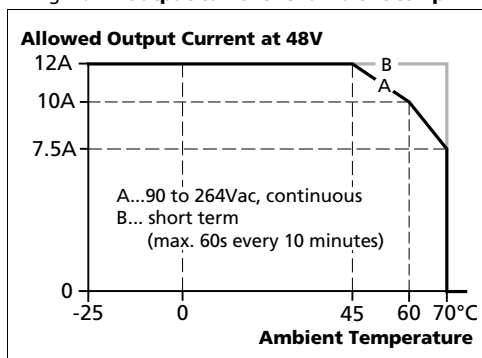
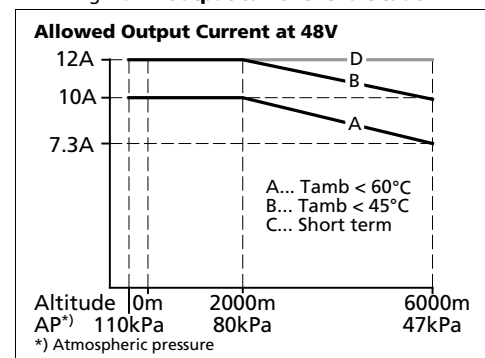

Fig. 16-2 Output current vs. altitude



17. SAFETY AND PROTECTION FEATURES

Isolation resistance	min.	500MΩ	At delivered condition between input and output, measured with 500Vdc
	min.	500MΩ	At delivered condition between input and PE, measured with 500Vdc
	min.	500MΩ	At delivered condition between output and PE, measured with 500Vdc
	min.	500MΩ	At delivered condition between output and DC-OK contacts, measured with 500Vdc
PE resistance	max.	0.1Ω	Resistance between PE terminal and the housing in the area of the DIN-rail mounting bracket.
Output over-voltage protection	typ.	58.5Vdc	In case of an internal defect, a redundant circuit limits the maximum output voltage. The output shuts down and automatically attempts to restart.
	max.	60Vdc	
Class of protection		I	According to IEC 61140 A PE (Protective Earth) connection is required
Degree of protection		IP 20	According to EN/IEC 60529
Over-temperature protection		Included	Output shuts down with automatic restart. Temperature sensors are installed on critical components inside the unit and turn the unit off in safety critical situations, which can happen e.g. when ambient temperature is too high, ventilation is obstructed or the de-rating requirements are not followed. There is no correlation between the operating temperature and turn-off temperature since this is dependent on input voltage, load and installation methods.
Input transient protection		MOV (Metal Oxide Varistor)	For protection values see chapter 15 (EMC).
Internal input fuse		Included	Not user replaceable slow-blow high-braking capacity fuse
Touch current (leakage current)	typ.	0.12mA / 0.31mA	At 100Vac, 50Hz, TN-,TT-mains / IT-mains
	typ.	0.18mA / 0.45mA	At 120Vac, 60Hz, TN-,TT-mains / IT-mains
	typ.	0.30mA / 0.76mA	At 230Vac, 50Hz, TN-,TT-mains / IT-mains
	max.	0.16mA / 0.38mA	At 110Vac, 50Hz, TN-,TT-mains / IT-mains
	max.	0.23mA / 0.55mA	At 132Vac, 60Hz, TN-,TT-mains / IT-mains
	max.	0.39mA / 0.94mA	At 264Vac, 50Hz, TN-,TT-mains / IT-mains

18. DIELECTRIC STRENGTH

The output voltage is floating and has no ohmic connection to the ground.

The output is insulated to the input by a double or reinforced insulation.

Type and routine tests are conducted by the manufacturer. Field tests may be conducted in the field using the appropriate test equipment which applies the voltage with a slow ramp (2s up and 2s down). Connect all input-terminals together as well as all output poles before conducting the test. When testing, set the cut-off current settings to the value in the table below.

We recommend that either the + pole or the – pole shall be connected to the protective earth system. This helps to avoid situations in which a load starts unexpectedly or cannot be switched off when unnoticed earth faults occur.

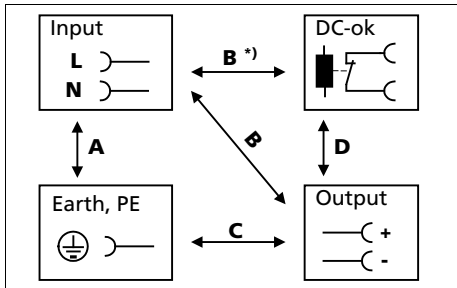

Fig. 18-1 Dielectric strength



		A	B	C	D
Type test	60s	2500Vac	3000Vac	1000Vac	500Vac
Routine test	5s	2500Vac	2500Vac	500Vac	500Vac
Field test	5s	2000Vac	2000Vac	500Vac	500Vac
Cut-off current setting for field test		> 10mA	> 10mA	> 20mA	> 1mA

B') When testing input to DC-OK ensure that the maximal voltage between DC-OK and the output is not exceeded (column D). We recommend connecting DC-OK pins and the output pins together when performing the test.

19. APPROVALS

IEC 61010-2-201	IECEE CB SCHEME	IEC 61010-2-201 Electrical Equipment for Measurement, Control and Laboratory Use - Particular requirements for control equipment
IEC 62368-1	IECEE CB SCHEME	IEC 62368-1 Audio/video, information and communication technology equipment - Safety requirements Output safety level: ES1
UL 61010-2-201		Listed equipment for category NMTR - UL 61010-2-201 Electrical Equipment for Measurement, Control and Laboratory Use - Particular requirements for control equipment Applicable for US and Canada E-File: E198865
EN 60079-0, EN 60079-7 ATEX		EN 60079-0 Explosive atmospheres - General requirements EN 60079-7, EN 60079-15 Equipment protection by type of protection "e" and "n" Temperature Code: T4 Type of Protection: ec nC Certificate: EPS 17 ATEX 1 089 X
IEC 60079-0, IEC 60079-7	IECEX	IEC 60079-0 Explosive atmospheres - General requirements IEC 60079-7, IEC 60079-15 Equipment protection by type of protection "e" and "n" Temperature Code: T4 Type of Protection: ec nC Certificate: IECEX EPS 17.0046X
IND. CONT. EQ. FOR HAZ. LOC. Class I Div 2 T4		Listed equipment for category NRAD - Listed equipment Industrial Control Equipment for Use in Hazardous Locations Applicable for USA and Canada Temperature Code: T4 Groups: A, B, C, D E-File: E327416
EAC TR Registration	EAC	Registration for the Eurasian Customs Union market (Russia, Kazakhstan, Belarus)

20. OTHER FULFILLED STANDARDS

EC Declaration of Conformity		The CE mark indicates conformance with the - RoHS directive - EMC directive and the - Low-voltage directive (LVD)
REACH Directive	REACH ✓	Directive 1907/2006/EU of the European Parliament and the Council of June 1 st , 2007 regarding the Registration, Evaluation, Authorisation and Restriction

IEC/EN 61558-2-16 (Annex BB) planned	Safety Isolating Transformer	of Chemicals (REACH) Safety Isolating Transformers corresponding to Part 2-6 of the IEC/EN 61558
--	---------------------------------	--

21. PHYSICAL DIMENSIONS AND WEIGHT

Width	48mm 1.89"
Height	124mm 4.88"
Depth	127mm 5.0"
	The DIN-rail height must be added to the unit depth to calculate the total required installation depth.
Weight	830g / 1.83lb
DIN-Rail	Use 35mm DIN-rails according to EN 60715 or EN 50022 with a height of 7.5 or 15mm.
Housing material	Body: Aluminium alloy Cover: zinc-plated steel
Installation clearances	See chapter 2
Penetration protection	Small parts like screws, nuts, etc. with a diameter larger than 5mm

Fig. 21-1 **Front view**

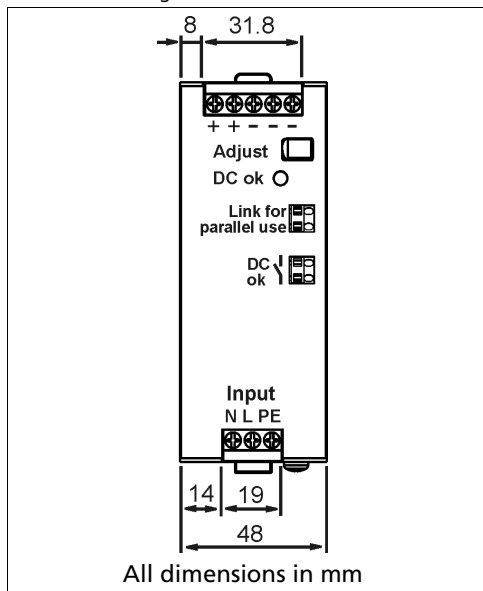
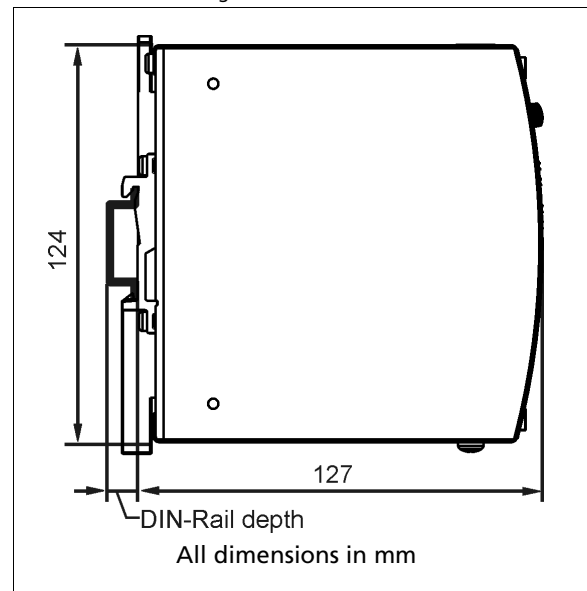

Fig. 21-2 **Side view**



22. ACCESSORIES

22.1. ZM10.WALL – WALL/PANEL MOUNT BRACKET

This bracket is used to mount the devices on a wall/panel without utilizing the DIN-Rail. The bracket can be mounted without detaching the DIN-rail brackets from the power supply. Product for illustration purpose only.

Fig. 22.1-1 Isometric view

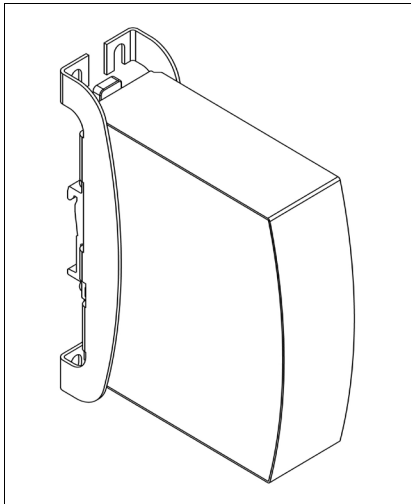

Fig. 22.1-2 Isometric view

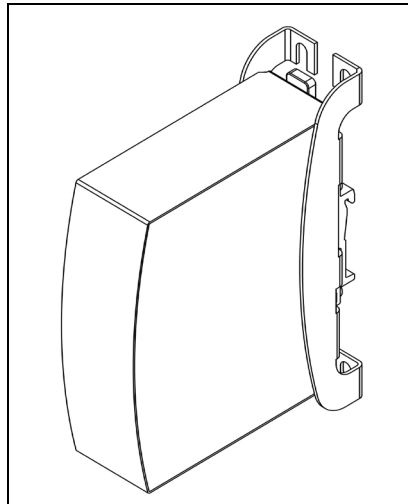

Fig. 22.1-3 Isometric view

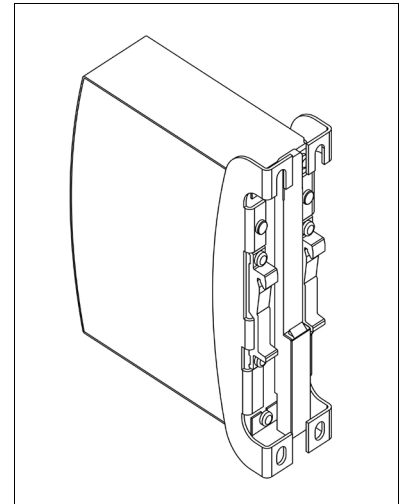

Fig. 22.1-4 Wall/panel mounting, front view

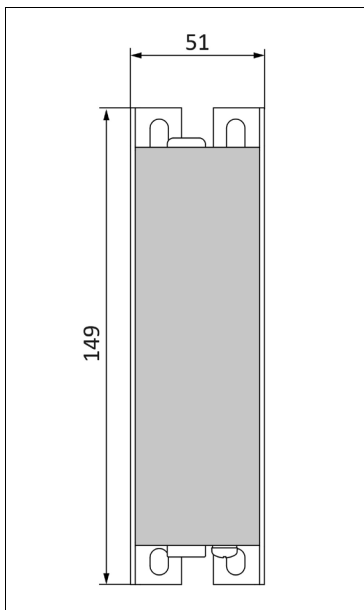

Fig. 22-5 Hole pattern for wall mounting

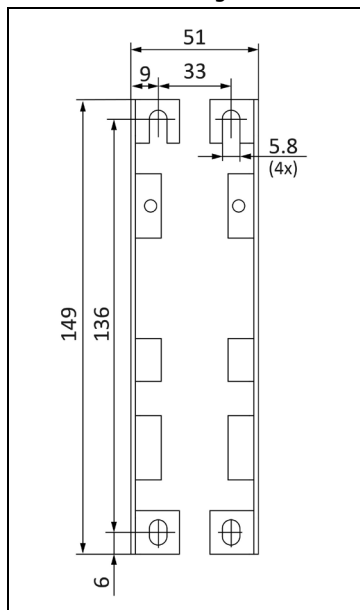
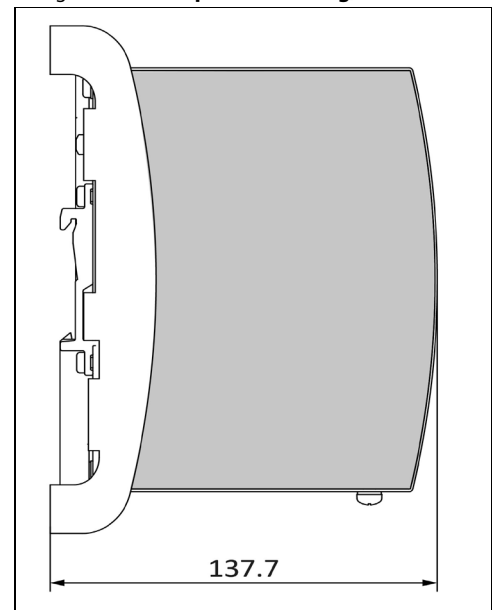

Fig. 22.1-6 Wall/panel mounting, side view



22.2. UF20.481 BUFFER MODULE



The UF20.481 buffer module is a supplementary device for DC 48V power supplies. It delivers power to bridge typical mains failures or extends the hold-up time after the AC power is turned off.

When the power supply provides a sufficient voltage, the buffer module stores energy in the integrated electrolytic capacitors. When the mains voltage is lost, the stored energy is released to the DC-bus in a regulated process.

The buffer module can be added in parallel to the load circuit at any given point and does not require any control wiring.

One buffer module can deliver 20A additional current and can be added in parallel to increase the output ampacity or the hold-up time.

22.3. YR40.482 - REDUNDANCY MODULE



The YR40.482 is a dual redundancy module, which can be used to build 1+1 or N+1 redundant systems.

The device is equipped with two 20A nominal input channels, which are individually decoupled by utilizing MOSFET technology. The output can be loaded with a nominal 40A continuous current.

Using MOSFETs instead of diodes reduces heat generation, losses and voltage drop between input and output. Due to these advantages, the unit is very narrow and only requires 46mm width on the DIN-rail.

The device does not require an additional auxiliary voltage and is self-powered even in case of a short circuit across the output. It requires suitable power supplies on the input, where the sum of the continuous short circuit current stays below 45A. This is typically achieved when the power supplies are featured with an intermittent overload behavior (Hiccup Mode).

See chapter 23.6 for wiring information.

23. APPLICATION NOTES

23.1. PEAK CURRENT CAPABILITY

The unit can deliver peak currents (up to several milliseconds) which are higher than the specified short term currents. This helps to start current demanding loads. Solenoids, contactors and pneumatic modules often have a steady state coil and a pick-up coil. The inrush current demand of the pick-up coil is several times higher than the steady-state current and usually exceeds the nominal output current. The same situation applies when starting a capacitive load. The peak current capability also ensures the safe operation of subsequent circuit breakers of load circuits. The load branches are often individually protected with circuit breakers or fuses. In case of a short or an overload in one branch circuit, the fuse or circuit breaker need a certain amount of over-current to open in a timely manner. This avoids voltage loss in adjacent circuits.

The extra current (peak current) is supplied by the power converter and the built-in large sized output capacitors of the power supply. The capacitors get discharged during such an event, which causes a voltage dip on the output. The following three examples show typical voltage dips for resistive loads:

Fig. 23-1 **20A peak current for 50ms, typ. (2x the nominal current)**

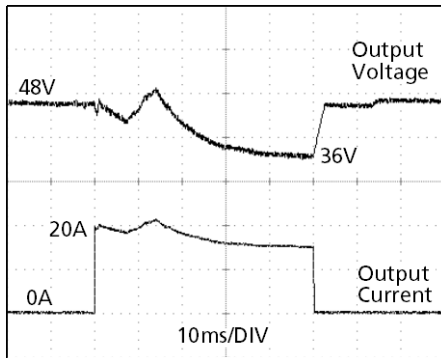

Fig. 23-2 **50A peak current for 5ms, typ. (5x the nominal current)**

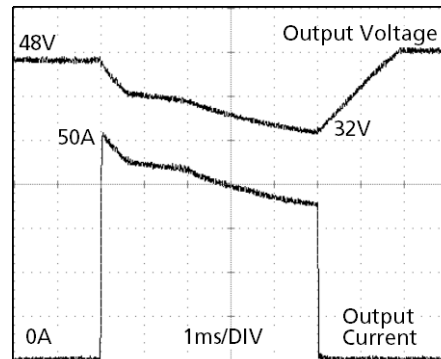
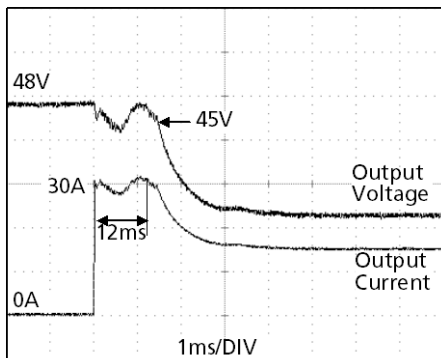

Fig. 23-3 **30A peak current for 12ms, typ. (3x the nominal current)**



Please note: The DC-OK relay might trigger when the voltage dips more than 10% for longer than 1ms.

Peak current voltage dips	typ.	from 48V to 36V	At 20A for 50ms, resistive load
	typ.	from 48V to 39V	At 50A for 2ms, resistive load
	typ.	from 48V to 32V	At 50A for 5ms, resistive load

23.2. OUTPUT CIRCUIT BREAKERS

Standard miniature circuit breakers (MCB's or UL 1077 circuit breakers) are commonly used for AC-supply systems and may also be used on 48V branches.

MCB's are designed to protect wires and circuits. If the ampere value and the characteristics of the MCB are adapted to the wire size that is used, the wiring is considered as thermally safe regardless of whether the MCB opens or not.

To avoid voltage dips and under-voltage situations in adjacent 24V branches which are supplied by the same source, a fast (magnetic) tripping of the MCB is desired. A quick shutdown within 10ms is necessary corresponding roughly to the ride-through time of PLC's. This requires power supplies with high current reserves and large output capacitors. Furthermore, the impedance of the faulty branch must be sufficiently small in order for the current to actually flow. The best current reserve in the power supply does not help if Ohm's law does not permit current flow. The following table has typical test results showing which B- and C-Characteristic MCBs magnetically trip depending on the wire cross section and wire length.

The following test results indicate the maximal wire length for a magnetic (fast) tripping. The wire length is always two times the distance to the load (+ and - wire).

Fig. 23-4 Test circuit for maximum wire length

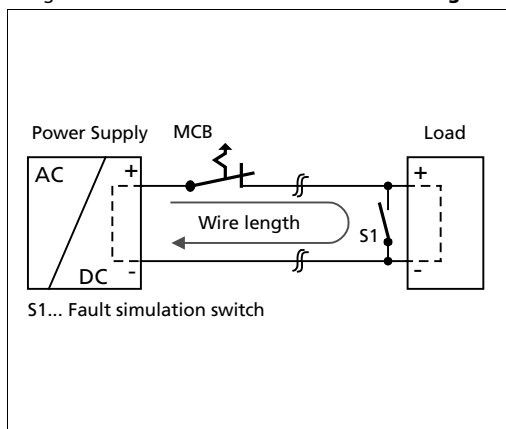

Test results for maximum wire length:

	0.75mm ²	1.0mm ²	1.5mm ²	2.5mm ²
C-2A	85 m	117 m	165 m	>200m
C-3A	54 m	85 m	117 m	176 m
C-4A	35 m	48 m	65 m	107 m
C-6A	13 m	19 m	25 m	39 m
C-8A	4 m	7 m	9 m	14 m
C-10A	3 m	6 m	8 m	13 m
C-13A		1 m	1 m	1 m
B-6A	36 m	52 m	75 m	116 m
B-10A	12 m	20 m	25 m	39 m
B-13A	9 m	13 m	17 m	28 m
B-16A	2 m	3 m	5 m	6 m

23.3. CHARGING OF BATTERIES

The power supply can be used to charge lead-acid or maintenance free batteries. Four 12V SLA or VRLA batteries are needed in series connection.

Instructions for charging batteries:

- a) Use only matched batteries when putting 12V types in series.
- b) Ensure that the ambient temperature of the power supply stays below 40°C.
- c) Use a 15A or 16A circuit breaker or a blocking diode between the power supply and the battery.
- d) Ensure that the output current of the power supply is below the allowed charging current of the battery.
- e) The return current to the power supply is typically 6mA. This return current can discharge the battery when the power supply is switched off except in case a blocking diode is utilized.
- f) Set the device into "Parallel Use" mode and adjust the output voltage, measured at no load and at the battery end of the cable, very precisely to the end-of-charge voltage.

End-of-charge voltage	55.6V	55.0V	54.3V	53.6V
Battery temperature	10°C	20°C	30°C	40°C

23.4. SERIES OPERATION

Devices of the same type can be connected in series for higher output voltages. It is possible to connect as many units in series as needed, providing the sum of the output voltage does not exceed 150Vdc. Voltages with a potential above 60Vdc must be installed with a protection against touching.

Avoid return voltage (e.g. from a decelerating motor or battery) which is applied to the output terminals.

Keep an installation clearance of 15mm (left / right) between two power supplies and avoid installing the power supplies on top of each other. Do not use power supplies in series in mounting orientations other than the standard mounting orientation.

Pay attention that leakage current, EMI, inrush current, harmonics will increase when using multiple devices.

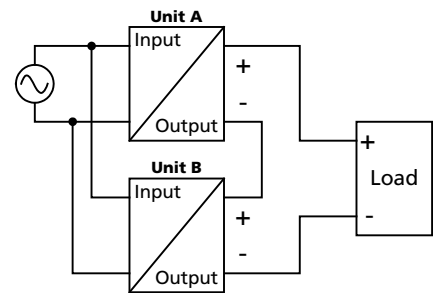

23.5. PARALLEL USE TO INCREASE OUTPUT POWER

Devices can be paralleled to increase the output power. The output voltage of all devices shall be adjusted to the same value ($\pm 100\text{mV}$) in "Single Use" mode with the same load conditions on all devices, or the devices can be left with the factory settings. After the adjustments, set the unit to "Parallel Use" mode, in order to achieve load sharing. The "Parallel Use" mode regulates the output voltage in such a manner that the voltage at no load is approx. 4% higher than at nominal load.

The ambient temperature is not allowed to exceed $+60^\circ\text{C}$.

If more than three devices are connected in parallel, a fuse or circuit breaker with a rating of 15A or 16A is required on each output. Alternatively, a diode or redundancy module can also be utilized.

Energize all devices at the same time. It also might be necessary to cycle the input power (turn-off for at least five seconds), if the output was in overload or short circuits and the required output current is higher than the current of one unit.

Keep an installation clearance of 15mm (left / right) between two devices and avoid installing devices on top of each other. Do not use devices in parallel in mounting orientations other than the standard mounting orientation or in any other condition where a reduction of the output current is required (e.g. altitude).

Pay attention that leakage current, EMI, inrush current will increase when using multiple devices.

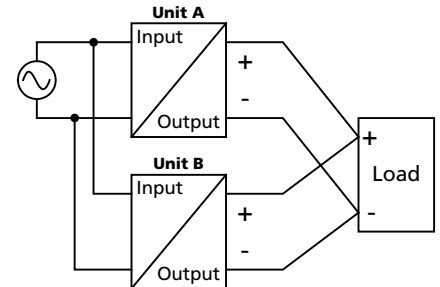

23.6. PARALLEL USE FOR REDUNDANCY

1+1 Redundancy:

Devices can be paralleled for redundancy to gain higher system availability. Redundant systems require a certain amount of extra power to support the load in case one device fails. The simplest way is to put two devices in parallel. This is called a 1+1 redundancy. In case one device fails, the other one is automatically able to support the load current without any interruption. It is essential to use a redundancy module to decouple devices from each other. This prevents that the defective unit becomes a load for the other device and the output voltage cannot be maintained any more.

1+1 redundancy allows ambient temperatures up to +70°C.

Pay attention that leakage current, EMI, inrush current, harmonics will increase when using multiple devices.

Recommendations for building redundant power systems:

- Use separate input fuses for each device.
- Use separate mains systems for each device whenever it is possible.
- Monitor the individual devices. Therefore, use the DC-OK signal of the device.
- It is desirable to set the output voltages of all devices to the same value ($\pm 100\text{mV}$) or leave it at the factory setting.
- Set the devices into "Parallel Use" mode.

N+1 Redundancy:

Redundant systems for a higher power demand are usually built in a N+1 method. E.g. four devices, each rated for 10A are paralleled to build a 30A redundant system.

Pay attention that leakage current, EMI, inrush current, harmonics will increase when using multiple devices.

Keep an installation clearance of 15mm (left / right) between two devices and avoid installing the devices on top of each other.

Do not use devices in parallel in mounting orientations other than the standard mounting orientation or in any other condition, where a reduction of the output current is required.

For N+1 redundancy the ambient temperature is not allowed to exceed +60°C.

Wiring examples for 1+1 and n+1 redundancy:

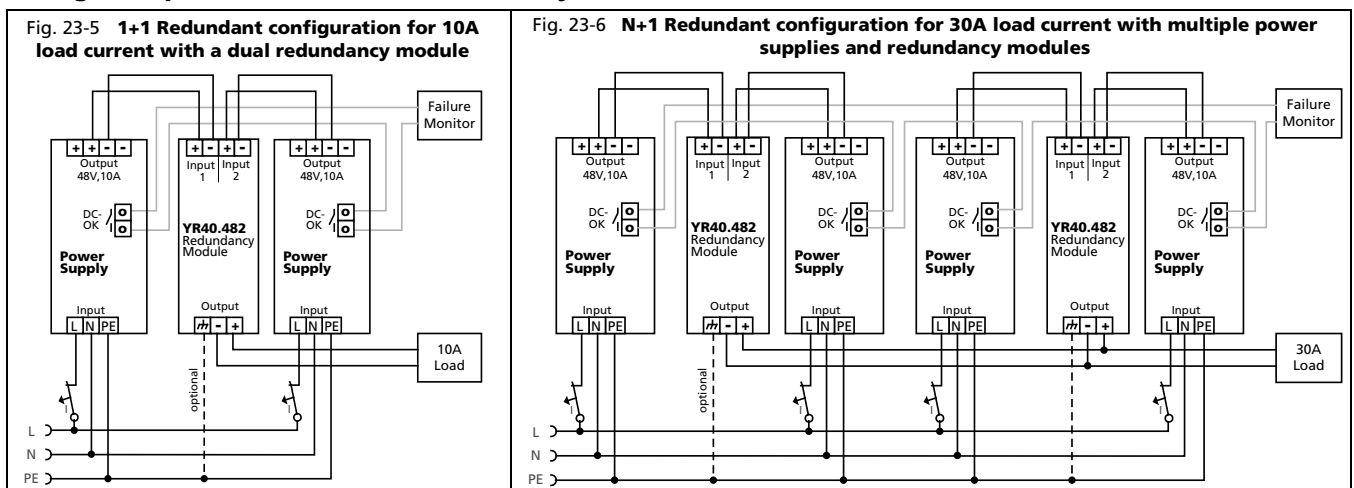

23.7. OPERATION ON TWO PHASES

The power supply can also be used on two-phases of a three-phase-system. Such a phase-to-phase connection is allowed as long as the supplying voltage is below $240V^{+10\%}$.

Ensure that the wire, which is connected to the N-terminal, is appropriately fused.

The maximum allowed voltage between a Phase and the PE must be below 300Vac.

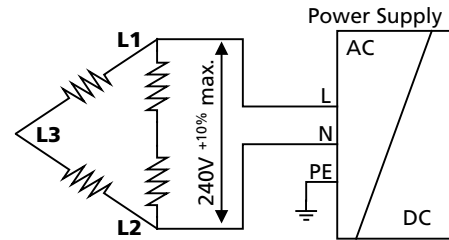

23.8. USE IN A TIGHTLY SEALED ENCLOSURE

When the device is installed in a tightly sealed enclosure, the temperature inside the enclosure will be higher than outside. In such situations, the inside temperature defines the ambient temperature for the device.

In the following test setup, the device is placed in the middle of the box, no other heat producing items are inside the box. The load is placed outside the box.

The temperature sensor inside the box is placed in the middle of the right side of the power supply with a distance of 1cm.

The following measurement results can be used as a reference to estimate the temperature rise inside the enclosure.

	Case A	Case B
Enclosure size	180x180x165mm Rittal Typ IP66 Box PK 9519 100, plastic	180x180x165mm Rittal Typ IP66 Box PK 9519 100, plastic
Input voltage	230Vac	230Vac
Load	48V, 8A; (=80%)	48V, 10A; (=100%)
Temperature inside the box	45.7°C	50.6°C
Temperature outside the box	24.6°C	25.6°C
Temperature rise	21.1K	25.0K

23.9. MOUNTING ORIENTATIONS

Mounting orientations other than input terminals on the bottom and output on the top require a reduction in continuous output power or a limitation in the maximum allowed ambient temperature.

The listed lifetime and MTBF values from this datasheet apply only for the standard mounting orientation.

The following curves give an indication for allowed output currents for altitudes up to 2000m (6560ft).

Fig. 23-7
Mounting Orientation A
(Standard orientation)

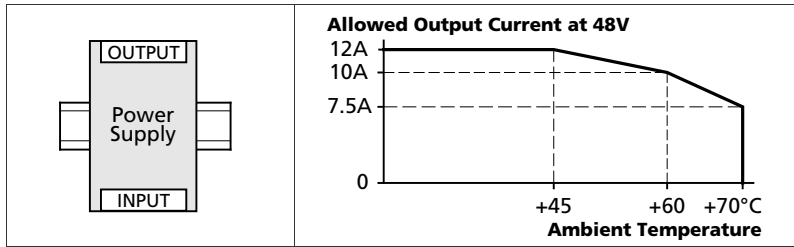

Fig. 23-8
Mounting Orientation B
(Upside down)

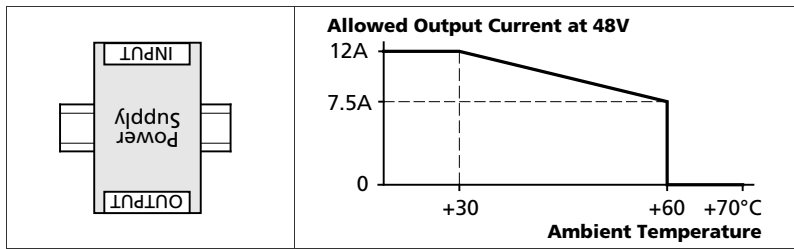

Fig. 23-9
Mounting Orientation C
(Table-top mounting)

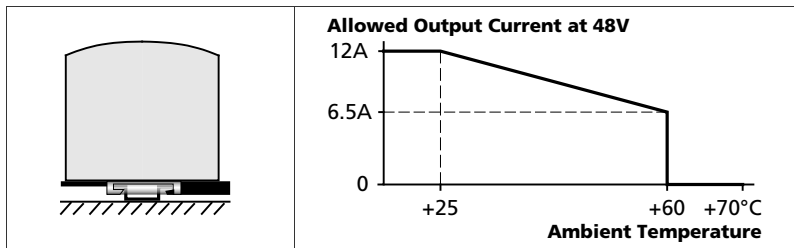

Fig. 23-10
Mounting Orientation D
(Horizontal cw)

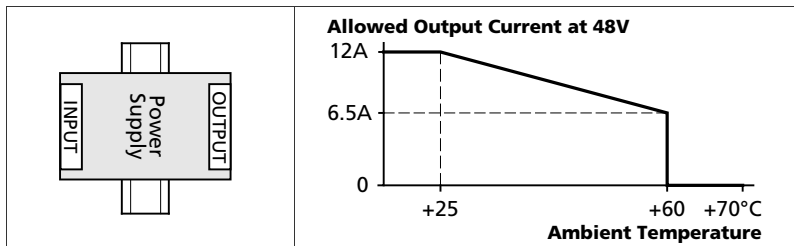
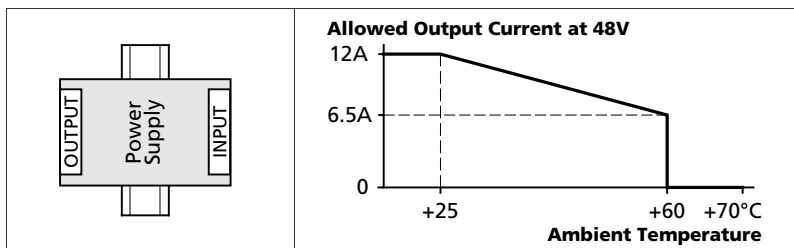

Fig. 23-11
Mounting Orientation E
(Horizontal ccw)



Nov. 2020 / Rev. 1.1a DS-CP20.481-EN All parameters are specified at 230Vac, 50Hz input voltage, 48V, 10A output load, 25°C ambient and after a 5 minutes run-in time unless otherwise noted.