

REFERENCE DRAWING

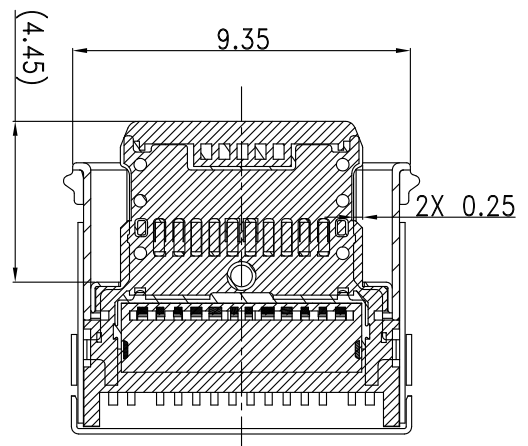

SECTION E-E
SCALE (1:1)

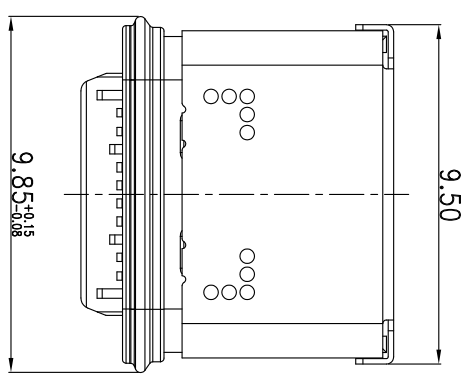
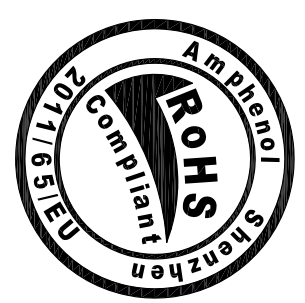

REV.	ECN NO.	MODIFY CONTENT	DATE
X4	1803XXXX	UPDATE WATERPROOF LEVEL	2018.03.27
X5	1804XXXX	Increase the solder joint	2018.04.10
X6	1805XXXX	UPDATE	2018.05.30

Pin No	Signal Name	Mating Sequence	Pin No	Signal Name	Mating Sequence
A1	GND	First	B12	GND	First
A2	TX1+	Second	B11	RX1+	Second
A3	TX1-	Second	B10	RX1-	Second
A4	Vbus	First	B9	Vbus	First
A5	CC1	Second	B8	SBU2	Second
A6	D+	Second	B7	D-	Second
A7	D-	Second	B6	D+	Second
A8	SBU1	Second	B5	CC2	Second
A9	Vbus	First	B4	Vbus	First
A10	RX2-	Second	B3	TX2-	Second
A11	RX2+	Second	B2	TX2+	Second
A12	GND	First	B1	GND	First
SHELL		GND	SHELL		GND

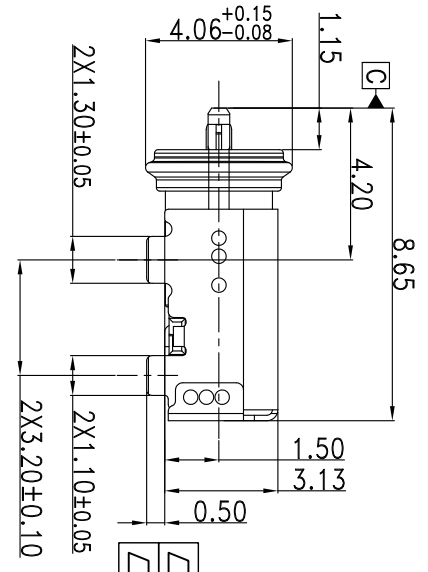
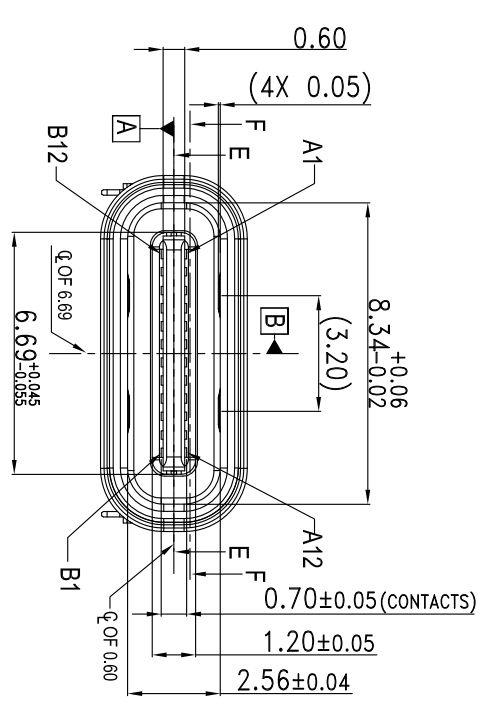

0.10 24x SMT TAILS (BEFORE IR)
0.12 24x SMT TAILS (AFTER IR)

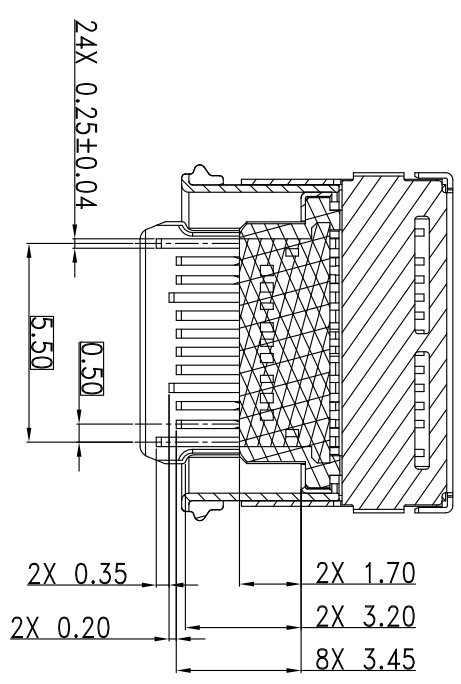
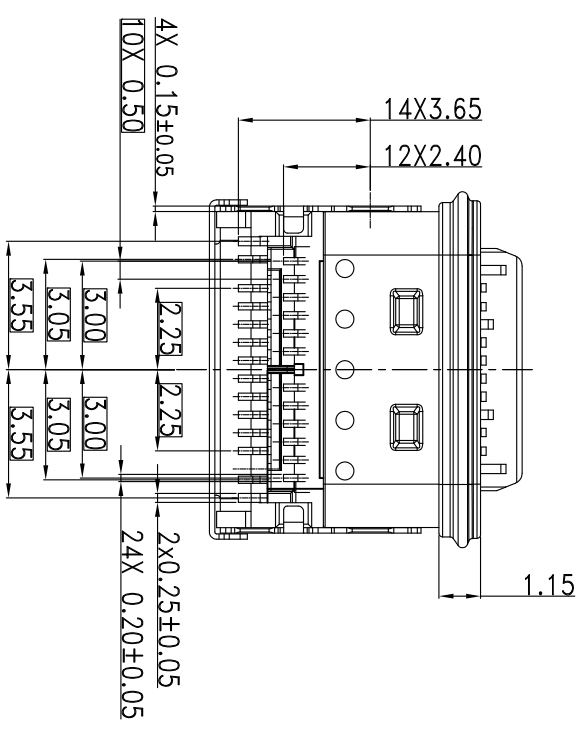
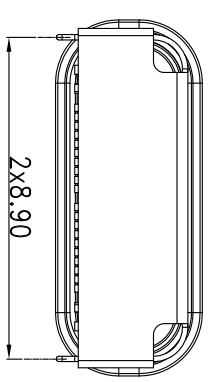

SECTION F-F
SCALE (1:1)

- NOTES:
- 1.MATERIAL :SEE TABLE "A"
 - 2.WATERPROOF : IPX7
 - 3.ELECTRICAL CHARACTERISTICS
LOW LEVEL CONTACT RESISTANCE: 40 MΩ Max
INSULATION RESISTANCE:100MΩ MIN
DIELECTRIC WITHSTANDING VOLTAGE:100 VAC:
CONTACT CURRENT RATING:5A Max
 - 4.MECHANICAL CHARACTERISTICS
INSERTION FORCE: 5~20N
EXTRACTION FORCE: 8~20N
AFTER DURABILITY EXTRACTION FORCE: 6~20N
 - 5.DURABILITY: 10000 CYCLES
 - 6.PACKAGING TYPE: CARRIER TAPE.
 - 7.MATERIAL SHOULD BE FULFILLED AMPHENOL SPEC# SSN002 AND CUSTOMER REQUIREMENTS, FOR HALOGEN FREE PRODUCTS, ALSO NEED TO MEET SSN004

GENERAL TOLERANCE		FILE.NO.	PART.NO.		DRAWN		MATERIAL	
X.±0.50	X.°±5°	REV.	C12401861	124018612112A	Veigar.Yang	DATE	SCALE	1:1
.X±0.38	.X°±2°	SIZE	X6	USB TYPE C CONNECTOR	Weison.Lu	2018.05.30	UNIT	MM
.XX±0.20	.XX±1°	A4	SHEET	1 OF 2	Tom.Tang	Amphenol Shouhmin Industry		

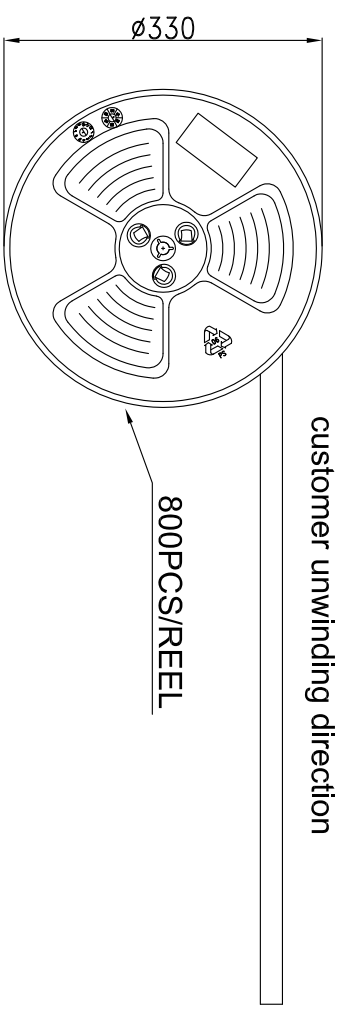
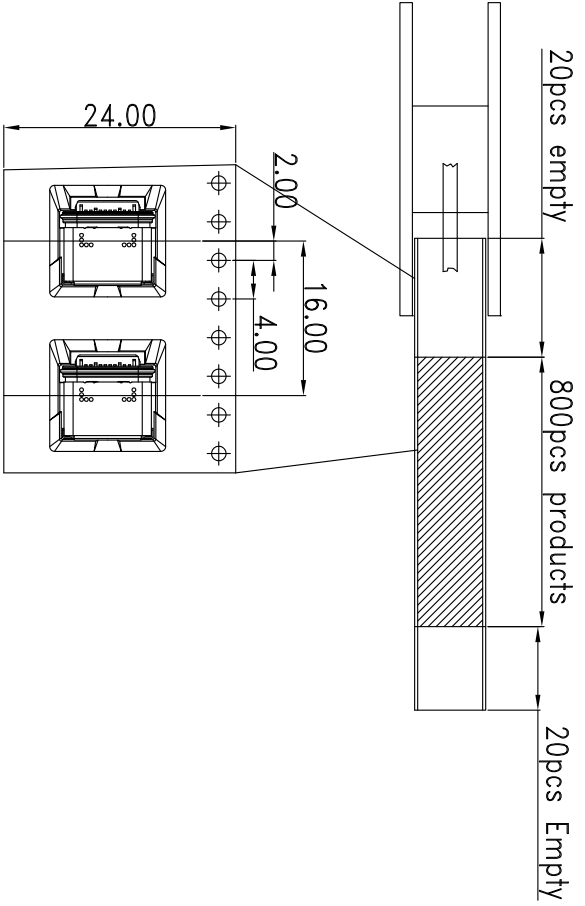
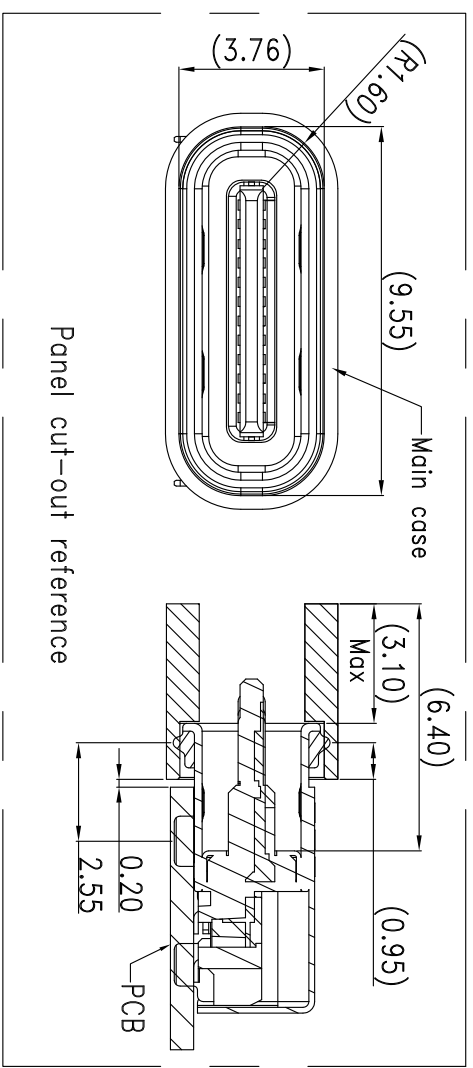

PACK DIRECTION

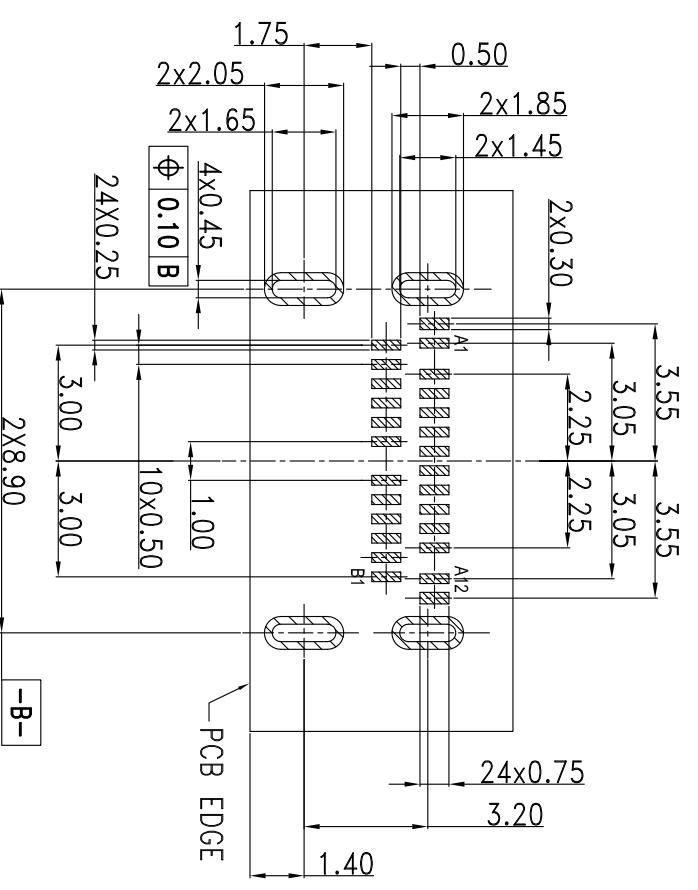
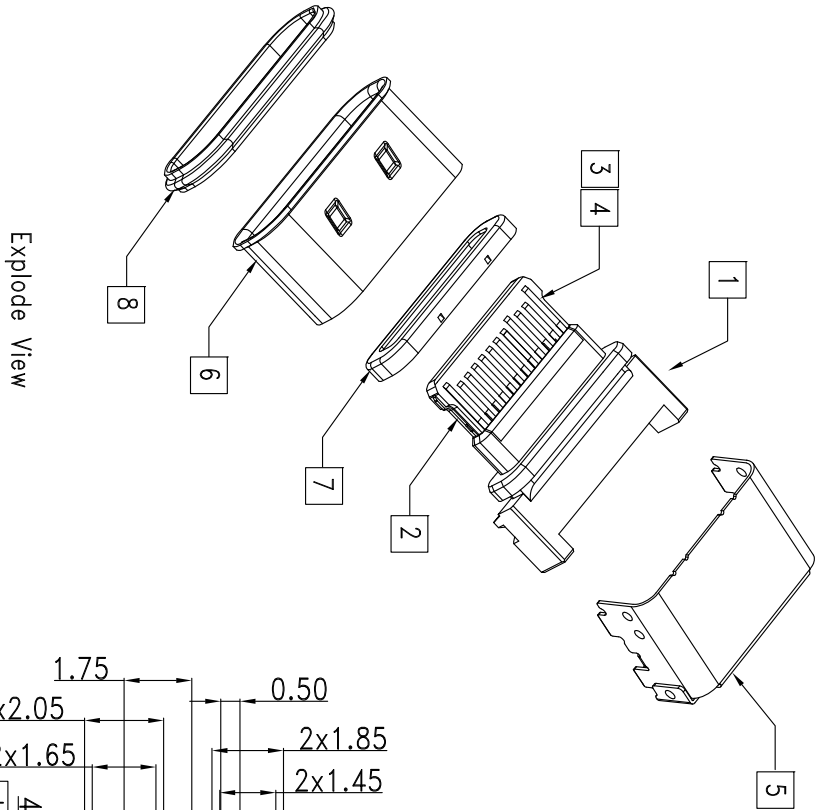
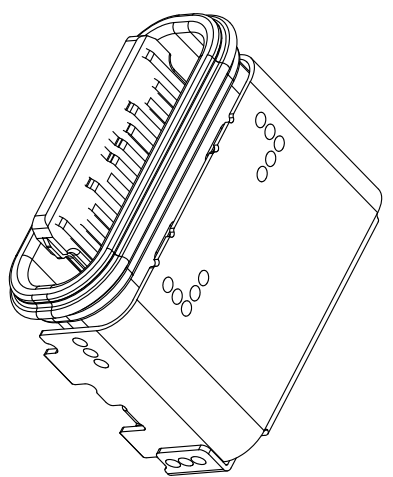

TABLE "A"

ITEM	DESCRIPTION	QTY	MATERIAL	FINISH
8	LIM	1	CHN-LIMS-60-A/B	BLACK
7	SMALL SHELL	1	SUS304-1/2H	NI PLATED OR CLEANING
6	MAIN SHELL	1	SUS304-1/2H	CLEANING
5	SUB-SHELL	1	SUS304-1/2H	NI PLATED
4	TOP TERMINAL	1	NKE012-EH	MATING AREA : Au30u"MIN SOLDER TAIL:Au 3~8u" , 50~150u" NICKEL OVERALL.
3	BOTTOM TERMINAL	1	NKE012-EH	MATING AREA : Au30u"MIN SOLDER TAIL:Au 3~8u" , 50~150u" NICKEL OVERALL.
2	MID PLATE	1	SUS301-H	NI PLATED
1	MAIN HOUSING	1	PA46 HFX31S	BLACK

BILL OF MATERIAL



GENERAL TOLERANCE	FILE.NO.	C12401861	PART.NO.	124018612112A	DRAWN	Veigar.Yang
X.±0.50	X.°±5°	REV.	X6	USB TYPE C CONNECTOR	CHECKED	Weison.Lu
.X±0.38	.X°±2°	SIZE	A4	2 OF 2	APPROVED	Tom.Tang
.XX±0.20	.XX±1°					

TITLE	SHEET	DATE	SCALE
USB TYPE C CONNECTOR	2 OF 2	2018.05.30	1:1

Amphenol Shouhmin Industry