

# SAC-5P- 2,0-U40/MINFS - Bus system cable



1416669

<https://www.phoenixcontact.com/us/products/1416669>

Please be informed that the data shown in this PDF document is generated from our Online Catalog. Please find the complete data in the user documentation. Our General Terms of Use for Downloads are valid.



Bus system cable, DeviceNet™, 5-position, PVC, gray, free cable end, on Socket straight 7/8"-16UNF, cable length: 2 m

## Commercial Data

Item number	1416669
Packing unit	1 pc
Minimum order quantity	1 pc
Note	Made to Order (non-returnable)
Sales Key	BF14
Product Key	BF1IMD
GTIN	4055626219325
Weight per Piece (including packing)	22.22 g
Weight per Piece (excluding packing)	22.22 g
Customs tariff number	85444290
Country of origin	MX

# SAC-5P- 2,0-U40/MINFS - Bus system cable



1416669

<https://www.phoenixcontact.com/us/products/1416669>

## Technical Data

### Notes

#### Trade restriction

CE note	The products are offered exclusively for export outside the EU and the European Economic Area.
---------	--

### Product properties

Product type	Sensor/actuator cable
Number of positions	5
Sensor type	DeviceNet™
Application	Standard
Shielded	yes
Coding	A

### Material specifications

Color Handle area	gray
Flammability rating according to UL 94	V-0
Material of grip body	PVC
Contact material	CuZn
Contact surface material	Au
Contact carrier material	PVC
Material for screw connection	Anodized aluminum

### Electrical properties

Contact resistance	≤ 5 mΩ
Insulation resistance	≥ 100 MΩ
Nominal voltage U <sub>N</sub>	300 V AC 300 V DC
Nominal current I <sub>N</sub>	8 A
Protective circuit	unwired

### Signaling

Status display	No
Status display present	No

### Connection data

#### Conductor connection

Tightening torque	10 lb <sub>F</sub> -in. 1.12 Nm
-------------------	------------------------------------

#### Pin assignment

Contact   Color (signal designation)   Contact (optional)	1   SR (shield)   1 (Socket) 2   RD (V+)   2 (Socket)
---	--

# SAC-5P- 2,0-U40/MINFS - Bus system cable



1416669

<https://www.phoenixcontact.com/us/products/1416669>

	3   BK (V-)   3 (Socket)
	4   WH (CAN_H)   4 (Socket)
	5   BU (CAN_L)   5 (Socket)

## Connector

### Connection 1

Type	free cable end
------	----------------

### Connection 2

Type	Socket straight 7/8"-16UNF
Number of positions	5
Coding type	A

## Cable/line

Cable length	2 m
--------------	-----

### DeviceNet trunk cable [U40]

Number of positions	5
Shielded	yes
Cable type	DeviceNet trunk cable [U40]
Conductor structure signal line	19 x AWG 30
Conductor cross section	2 x AWG 18 data cable 2 x AWG 15 power supply 1 x AWG 18 drain wire
External cable diameter	11.43 mm
Outer sheath, material	PVC
External sheath, color	gray
Conductor material	Tin-plated Cu litz wires
Material wire insulation	Foamed PE PVC (Power supply)
Single wire, color	red-black, blue-white
Twisted pairs	2 cores to the pair
Type of pair shielding	Plastic-coated aluminum foil, aluminum side outside
Overall twist	2 pairs around a drain wire in the center to the core
Optical shield covering	65 %
Flame resistance	UL 1581, FT4
Resistance to oil	OIL RES I according to UL 2256
Other resistance	UV resistant (720 h) UL 2556
Ambient temperature (operation)	-20 °C ... 75 °C (cable, fixed installation) -5 °C ... 80 °C (Cable, flexible installation)

## Environmental and real-life conditions

### Ambient conditions

Degree of protection	IP68
----------------------	------

# SAC-5P- 2,0-U40/MINFS - Bus system cable



1416669

<https://www.phoenixcontact.com/us/products/1416669>

Ambient temperature (operation)	-20 °C ... 75 °C (Plug / socket)
	-20 °C ... 75 °C (cable, fixed installation)
	-5 °C ... 80 °C (Cable, flexible installation)

## Standards and regulations

Other resistance	UL 2556
------------------	---------

# SAC-5P- 2,0-U40/MINFS - Bus system cable

1416669

<https://www.phoenixcontact.com/us/products/1416669>

## Drawings

Circuit diagram

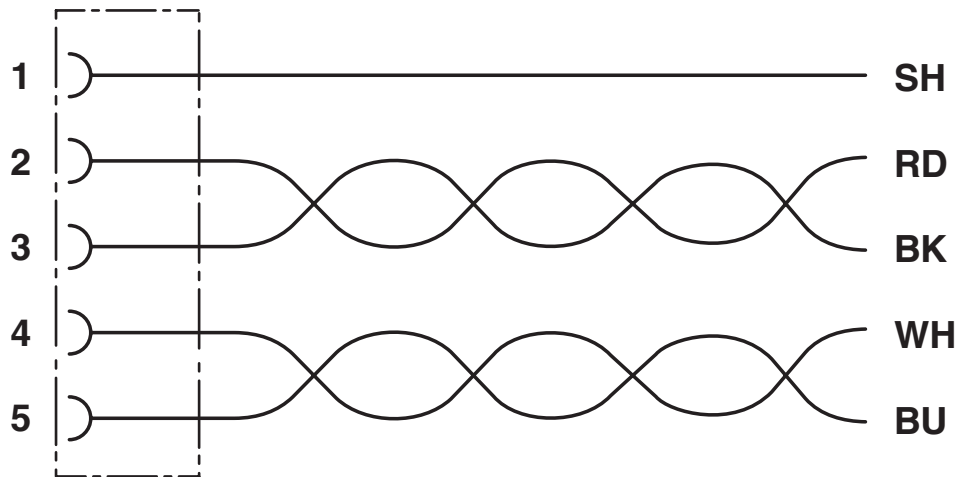

Schematic diagram

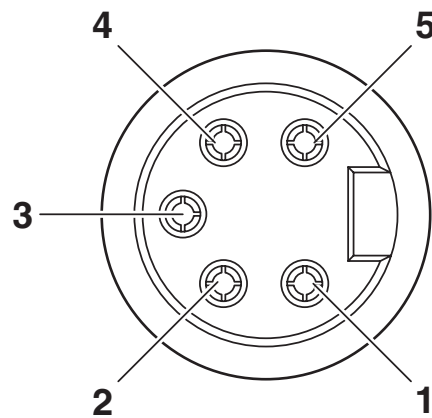

Pin assignment, socket, 7/8"-16UNF, 5-pos., view of female side

# SAC-5P- 2,0-U40/MINFS - Bus system cable



1416669

<https://www.phoenixcontact.com/us/products/1416669>

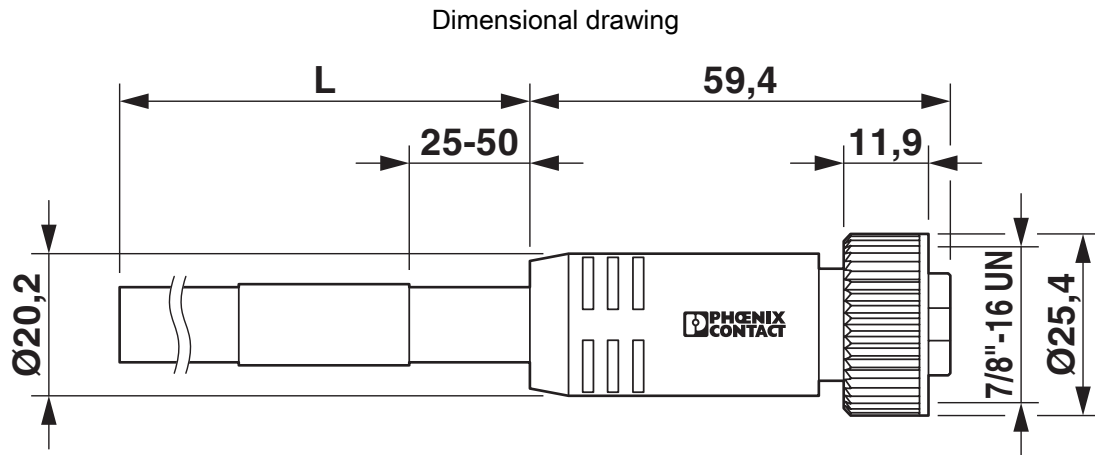

7/8''-16UNF socket, straight

# SAC-5P- 2,0-U40/MINFS - Bus system cable



1416669

<https://www.phoenixcontact.com/us/products/1416669>

## Approvals



**EAC**

Approval ID: RU C-DE.BL08.B.00286



**UL Listed**

Approval ID: FILE E 221474



**cUL Listed**

Approval ID: FILE E 221474

# SAC-5P- 2,0-U40/MINFS - Bus system cable



1416669

<https://www.phoenixcontact.com/us/products/1416669>

## Classifications

### ECLASS

ECLASS-11.0	27060307
ECLASS-12.0	27060307
ECLASS-13.0	27060307

### ETIM

ETIM 7.0	EC001855
----------	----------

### UNSPSC

UNSPSC 21.0	31251501
-------------	----------



# SAC-5P- 2,0-U40/MINFS - Bus system cable



1416669

<https://www.phoenixcontact.com/us/products/1416669>

## Environmental Product Compliance

China RoHS	Environmentally friendly use period: unlimited = EFUP-e
	No hazardous substances above threshold values

Phoenix Contact 2023 © - all rights reserved  
<https://www.phoenixcontact.com>

Phoenix Contact USA  
586 Fulling Mill Road  
Middletown, PA 17057, United States  
(+717) 944-1300  
[info@phoenixcon.com](mailto:info@phoenixcon.com)