

## FEATURES

- 6 A (typical) peak drive output capability**
- Internal turn off NFET, on resistance:  $<1\ \Omega$**
- Internal turn on PFET, on resistance:  $<1.2\ \Omega$**
- 2 overcurrent protection methods**
  - Desaturation detection**
  - Split emitter overcurrent detection**
- Miller clamp output with gate sense input**
- Isolated fault output**
- Isolated temperature sensor readback**
- Propagation delay**
  - Rising: 95 ns typical**
  - Falling: 100 ns typical**
- Minimum pulse width: 74 ns**
- Operating junction temperature range:  $-40^{\circ}\text{C}$  to  $+150^{\circ}\text{C}$**
- $V_{DD1}$  and  $V_{DD2}$  UVLO**
- Minimum external tracking (creepage): 8.3 mm (pending)**
- Safety and regulatory approvals**
  - 5000 V rms for 1 minute per UL 1577**
  - CSA Component Acceptance Notice 5A**
  - DIN V VDE V 0884-10 (VDE V 0884-10):2006-12**
  - $V_{IORM} = 849\ V_{PEAK}$  (reinforced/basic)**
- Qualified for automotive applications**

## APPLICATIONS

- MOSFET and IGBT gate drivers**
- Photovoltaic (PV) inverters**
- Motor drives**
- Power supplies**

## GENERAL DESCRIPTION

The ADuM4138 is a single-channel gate driver optimized for driving insulated gate bipolar transistors (IGBTs). Analog Devices, Inc., iCoupler® technology provides isolation between the input signal and the output gate drive.

The Analog Devices chip scale transformers also provide isolated communication of control information between the high voltage

and low voltage domains of the chip. Information on the status of the chip can be read back from the dedicated outputs.

The ADuM4138 includes an isolated flyback controller, allowing simple secondary voltage generation.

Overcurrent detection is integrated in the ADuM4138 to protect the IGBT in case of desaturation and/or overcurrent events. The overcurrent detection is coupled with a high speed, two-level turn off function in case of faults.

The ADuM4138 provides a Miller clamp control signal for a metal-oxide semiconductor field effect transistor (MOSFET) to provide IGBT turn off, with a single rail supply when the Miller clamp voltage threshold drops below 2 V (typical) above GND<sub>2</sub>. Operation with unipolar secondary supplies is possible with or without the Miller clamp operation.

A low gate voltage detection circuit can trigger a fault if the gate voltage does not rise above the internal threshold within the time allowed after turn on (12.8  $\mu\text{s}$  typical). The low voltage detection circuit detects IGBT device failures that exhibit gate shorts or other causes of weak drive.

Two temperature sensor pins, TS1 and TS2, allow isolated monitoring of system temperatures at the IGBTs. The secondary undervoltage lockout (UVLO) is set to 11.2 V (typical) in accordance with common IGBT threshold levels.

A serial peripheral interface (SPI) bus on the primary side of the device provides in field programming of temperature sensing diode gains and offsets to the ADuM4138. Values are stored on an electrically erasable programmable read-only memory (EEPROM) located on the secondary side of the device. In addition, programming is available for specific  $V_{DD2}$  voltages, temperature sensing reporting frequencies, and overcurrent blanking times.

The ADuM4138 provides isolated fault reporting for overcurrent events, remote temperature overheating events, UVLO, thermal shutdown (TSD), and desaturation detection.

Protected by U.S. Patents 5,952,849; 6,873,065; and 7,075,329. Other patents pending.

Rev. A

[Document Feedback](#)

Information furnished by Analog Devices is believed to be accurate and reliable. However, no responsibility is assumed by Analog Devices for its use, nor for any infringements of patents or other rights of third parties that may result from its use. Specifications subject to change without notice. No license is granted by implication or otherwise under any patent or patent rights of Analog Devices. Trademarks and registered trademarks are the property of their respective owners.

One Technology Way, P.O. Box 9106, Norwood, MA 02062-9106, U.S.A.  
Tel: 781.329.4700 ©2018–2019 Analog Devices, Inc. All rights reserved.  
[Technical Support](#) [www.analog.com](http://www.analog.com)

## TABLE OF CONTENTS

Features .....	1	Theory of Operation .....	13
Applications.....	1	Applications Information .....	14
General Description .....	1	PCB Layout .....	14
Revision History .....	2	Isolated Flyback Controller.....	14
Functional Block Diagram .....	3	SPI and EEPROM Operation.....	14
Specifications.....	4	User Register Map .....	15
Electrical Characteristics .....	4	User Register Bits .....	15
SPI Timing Specifications .....	7	Configuration Register Bits.....	15
Package Characteristics .....	7	Control Register Bits .....	17
Regulatory Information (Pending) .....	8	Propagation Delay Related Parameters .....	18
Insulation and Safety-Related Specifications.....	8	Protection Features .....	18
DIN V VDE V 0884-10 (VDE V 0884-10) Insulation		Power Dissipation.....	22
Characteristics (Pending).....	9	Insulation Lifetime .....	22
Recommended Operating Conditions .....	9	DC Correctness and Magnetic Field Immunity.....	23
Absolute Maximum Ratings.....	10	Typical Application Circuit.....	23
Thermal Resistance .....	10	Outline Dimensions .....	24
ESD Caution.....	10	Ordering Guide .....	24
Pin Configuration and Function Descriptions.....	11	Automotive Products .....	24
Typical Performance Characteristics .....	12		

## REVISION HISTORY

### 8/2019—Rev. 0 to Rev. A

Changes to Figure 1 .....	3
Change to Overcurrent Detection Section.....	18
Changes to Figure 18.....	19
Changes to Figure 20.....	20
Changes to Figure 24.....	21
Changes to Figure 30.....	23

### 12/2018—Revision 0: Initial Version

# FUNCTIONAL BLOCK DIAGRAM

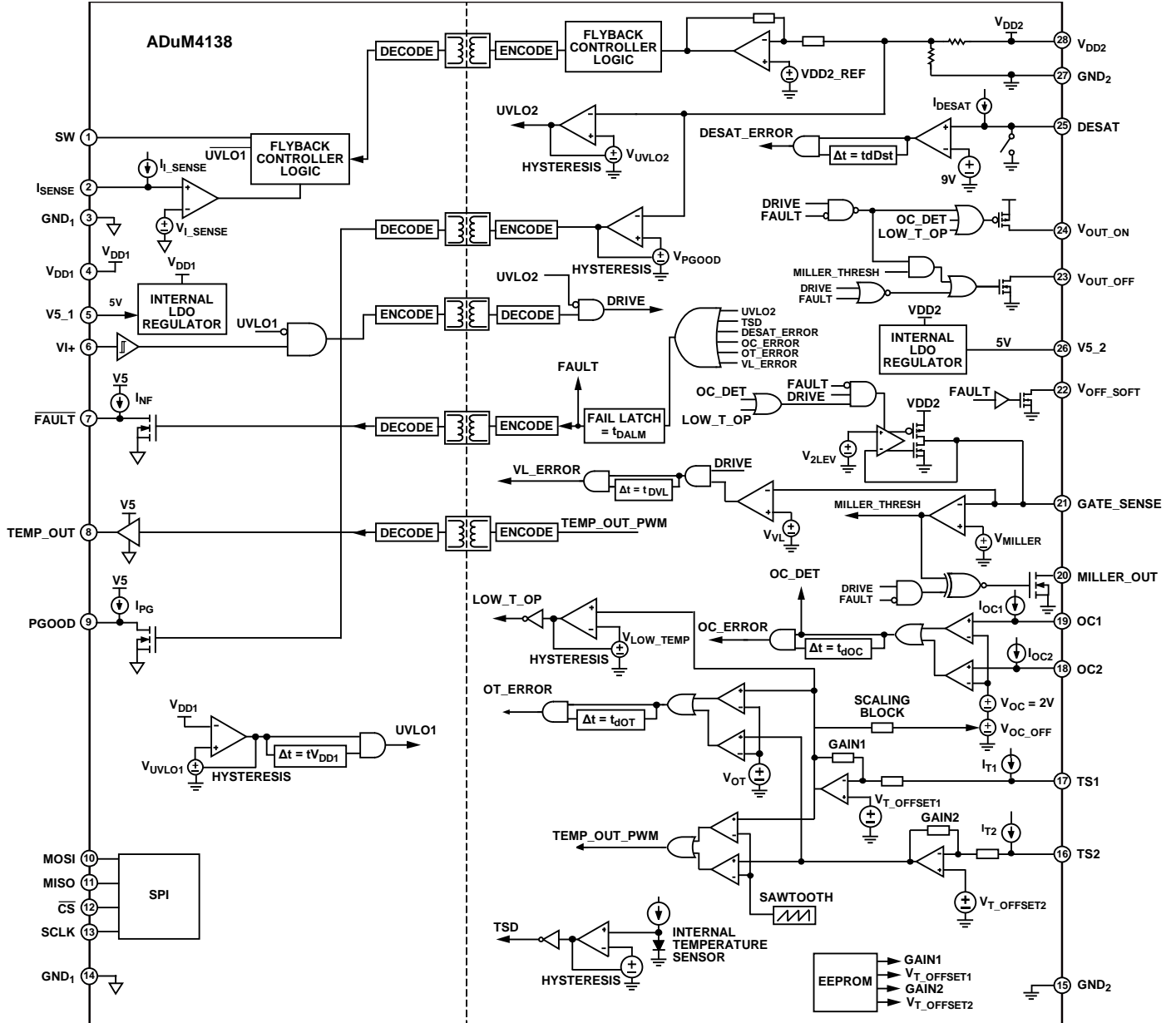

**NOTES**

1. VL\_ERROR IS THE VOLTAGE LOW ERROR INTERNAL CONNECTION.
2. TEMP\_OUT\_PWM IS THE TEMPERATURE SENSE INTERNAL CONNECTION.
3. OC\_ERROR IS THE OVERCURRENT ERROR INTERNAL CONNECTION.
4. OC\_DET IS THE OVERCURRENT DETECTION INTERNAL CONNECTION.
5. VDD2\_REF IS THE REFERENCE VOLTAGE FOR V<sub>DD2</sub>.
6. DESAT\_ERROR IS THE DESAT DETECTION ERROR INTERNAL CONNECTION.
7. MILLER\_THRESH IS THE REFERENCE FOR THE MILLER THRESHOLD ACTIVATION.
8. OT\_ERROR IS THE OVERTEMPERATURE ERROR INTERNAL CONNECTION.
9. V<sub>T\_OFFSET1</sub> IS THE TEMPERATURE SENSE OFFSET VOLTAGE FOR THE TS1 PIN.
10. V<sub>T\_OFFSET2</sub> IS THE TEMPERATURE SENSE OFFSET VOLTAGE FOR TS2 PIN.
11. I<sub>T1</sub> IS THE INTERNAL CURRENT REFERENCE FOR TS1 PIN.
12. I<sub>T2</sub> IS THE INTERNAL CURRENT REFERENCE FOR TS2 PIN.
13. V<sub>OC\_OFF</sub> IS THE OVERCURRENT VOLTAGE OFFSET DUE TO TEMPERATURE RAMP.
14. V<sub>OC</sub> IS THE OVERCURRENT REFERENCE VOLTAGE.
15. MILLER\_THRESH IS THE ACTIVE MILLER CLAMP INTERNAL CONTROL CONNECTION.
16. I<sub>OC1</sub> IS THE OC1 INTERNAL PULL-UP CURRENT SOURCE.
17. I<sub>OC2</sub> IS THE OC2 INTERNAL PULL-UP CURRENT SOURCE.
18. V<sub>PGOOD</sub> IS THE PGOOD VOLTAGE REFERENCE.
19. V<sub>UVLO1</sub> IS THE V<sub>DD1</sub> UVLO REFERENCE.
20. V<sub>LOW\_TEMP</sub> IS THE LOW TEMPERATURE OPERATION REFERENCE.
21. V<sub>2LEV</sub> IS THE TARGET VOLTAGE REFERENCE FOR TWO LEVEL OPERATION.
22. LOW\_T\_OP IS THE LOW TEMPERATURE OPERATION TRIGGER.

Figure 1.

## SPECIFICATIONS

## ELECTRICAL CHARACTERISTICS

Low-side voltages referenced to GND<sub>1</sub> and high-side voltages referenced to GND<sub>2</sub>. V<sub>DD1</sub> = 12 V, V<sub>DD2</sub> = 16 V, T<sub>A</sub> = -40°C to +125°C, unless otherwise noted. All minimum and maximum specifications apply over the entire recommended operating junction temperature range, unless otherwise noted. All typical specifications are at T<sub>A</sub> = 25°C, V<sub>DD1</sub> = 12 V, and V<sub>DD2</sub> = 16 V, unless otherwise noted.

Table 1.

Parameter	Symbol	Min	Typ	Max	Unit	Test Conditions/Comments
DIGITAL CONVERTER SPECIFICATIONS						
High-Side Power Supply						
Input Voltage	V <sub>DD2</sub>	12		25	V	Operating without flyback TS1 = TS2 = open, VI+ = 0 V, V <sub>DD2</sub> = 25 V
Input Current, Quiescent for V <sub>DD2</sub>	I <sub>DD2(Q)</sub>		14	18	mA	
V5_2 Regulated Output Voltage	V5_2	4.9	5	5.1	V	
Isolated Flyback						
Soft Start	t <sub>SS</sub>		44	50	ms	All FLYBACK_V codes
Output Voltage	V <sub>FB</sub>	V <sub>DD2</sub> - 2.6%	V <sub>DD2</sub>	V <sub>DD2</sub> + 2.5%	V	
		15.6	16	16.4	V	For FLYBACK_V code of 0111
Flyback Operating Frequency	f <sub>SW</sub>	180	200	220	kHz	
Maximum						
Duty Cycle	D <sub>MAX</sub>	83.5	86	90	%	
On Time	t <sub>MAX_ON</sub>	4.2	4.8	5.4	μs	
Flyback Switch R <sub>DS(on)</sub>						
Negative Channel Field Effect Transistor (NFET)	R <sub>DS(on)_SW_N</sub>		1.6	3.0	Ω	SW current (I <sub>SW</sub> ) = 20 mA
Positive Channel Field Effect Transistor (PFET)	R <sub>DS(on)_SW_P</sub>		1.7	2.8	Ω	I <sub>SW</sub> = 20 mA
Logic Supply						
V <sub>DD1</sub> Input Voltage	V <sub>DD1</sub>	6.0		25	V	No load TS1 = TS2 = open, VI+ = 0 V, TEMP_OUT and SW floating, V <sub>DD1</sub> = 25 V, V <sub>DD2</sub> = 25 V
V5_1 Regulated Output Voltage	V <sub>V5_1</sub>	4.9	5.0	5.1	V	
V <sub>DD1</sub> Input Current	I <sub>DD1</sub>		4.0	5.0	mA	
Logic Inputs (VI+, MOSI, SCLK, $\overline{CS}$ )						
Input Current	I <sub>I</sub>		0.1	1.0	μA	
Input Voltage						
Logic High	V <sub>IH</sub>	2.5			V	
Logic Low	V <sub>IL</sub>			0.9	V	
Logic Input Hysteresis	V <sub>HYST</sub>		1.10		V	
Logic Output						
MISO NFET R <sub>DS(on)</sub>	R <sub>DS(on)_MISO_N</sub>		9	16	Ω	MISO current (I <sub>MISO</sub> ) = 5 mA
MISO PFET R <sub>DS(on)</sub>	R <sub>DS(on)_MISO_P</sub>		12.5	22	Ω	I <sub>MISO</sub> = 5 mA
MISO PFET High-Z Leakage	I <sub>MISO_LK_P</sub>			20.0	μA	MISO = 5 V
UVLO						
Positive Going Threshold						
V <sub>DD1</sub>	V <sub>VDD1UV+</sub>		4.25	4.5	V	
V <sub>DD2</sub>	V <sub>VDD2UV+</sub>		11.6	11.8	V	
Negative Going Threshold						
V <sub>DD1</sub>	V <sub>VDD1UV-</sub>	4.0	4.13		V	
V <sub>DD2</sub>	V <sub>VDD2UV-</sub>	11.0	11.2		V	
Hysteresis						
V <sub>DD1</sub>	V <sub>VDD1UVH</sub>		0.1		V	
V <sub>DD2</sub>	V <sub>VDD2UVH</sub>		0.3		V	

Parameter	Symbol	Min	Typ	Max	Unit	Test Conditions/Comments
<b>PGOOD</b>						
Threshold Rising	V <sub>PGOOD_R</sub>	12.4	13.0	13.45	V	For FLYBACK_V code of 0000
		17.3	18.2	18.8	V	For FLYBACK_V code of 1111
Threshold Falling	V <sub>PGOOD_F</sub>	11.77	12.3	12.75	V	For FLYBACK_V code of 0000
		16.64	17.2	17.76	V	For FLYBACK_V code of 1111
Pull-Down NFET Resistance	R <sub>PGOOD_PD</sub>		14	24	Ω	PGOOD current (I <sub>PGSW</sub> ) = 10 mA
Pull-Up Current Source	I <sub>PG</sub>	66	78	88	μA	PGOOD = 0 V, V <sub>DD1</sub> = 12 V
Filter Time						
Active	t <sub>PGOOD_FILT1</sub>	30	40	50	μs	
Cleared	t <sub>PGOOD_FILT2</sub>	0.5	2.25	4	μs	
<b>FAULT</b>						
Pull-Down NFET Resistance	R <sub>NFLT_PD_FET</sub>		16	28	Ω	FAULT current (I <sub>FT</sub> ) = 10 mA
Pull-Up Current Source	I <sub>NF</sub>	66	78	88	μA	FAULT = 0 V, V <sub>DD1</sub> = 12 V
Hold Time	t <sub>DALM</sub>	23.3	26.4	30.2	ms	
<b>Low Gate Voltage</b>						
Reference Voltage	V <sub>VL</sub>	9.6	10	10.4	V	
Detect Delay Time	t <sub>DVL</sub>	10.3	12.8	15.6	μs	
Fault Delay Time	t <sub>DVL_FLT</sub>	530	735	940	ns	
<b>Overcurrent</b>						
<b>Voltage</b>						
Temperature, Disabled	V <sub>OCD_TH</sub>		2		V	T_RAMP_OP = 1
Temperature, Enabled	V <sub>OCD_TH_EN</sub>	2.59	2.69	2.76	V	T_RAMP_OP = 0, TS1 = 1.55 V
		1.65	1.75	1.82	V	T_RAMP_OP = 0, TS1 = 2.45 V
<b>Hysteresis</b>						
Temperature, Disabled	V <sub>OCD_HYST</sub>		0.17		V	T_RAMP_OP = 1
Temperature, Enabled	V <sub>OCD_HYST_EN</sub>		0.17		V	T_RAMP_OP = 0, TS1 = 1.55 V
			0.17		V	T_RAMP_OP = 0, TS1 = 2.45 V
Detect Delay Time	t <sub>dOC</sub>	520	920	1340	ns	OC_2LEV_OP = 0, OC_TIME_OP = 0
Fault Delay Time	t <sub>dOC_FLT</sub>	510	735	960	ns	OC_2LEV_OP = 1
Detect Blanking	t <sub>BLANK</sub>	0.275	0.36	0.47	μs	t <sub>BLANK</sub> bits = 0001
Pin Pull-Up Current Source	I <sub>OC</sub>	3.8	5	6.2	μA	V <sub>DD2</sub> = 25 V, OC1 = OC2 = 0 V
<b>Desaturation (DESAT) Detect</b>						
<b>Comparator Threshold</b>						
Rising	V <sub>DESAT_R</sub>	8.4	8.9	9.4	V	
Falling	V <sub>DESAT_F</sub>	7.7	8.1	8.5	V	
Hysteresis	V <sub>DESAT_H</sub>		0.85		V	
Internal Current Source	I <sub>DESAT</sub>	365	490	570	μA	DESAT = 0 V
Fault Delay Time	t <sub>DESAT_DELAY</sub>	620	825	1030	ns	
FAULT Pin Blank Time	t <sub>DESAT_BLANK</sub>	300	450	620	ns	
DESAT Pin Pull-Down Resistance	R <sub>DSON_DESAT</sub>		14	28	Ω	DESAT current (I <sub>D</sub> ) = 10 mA
<b>TSD</b>						
<b>Primary Side TSD</b>						
Positive Edge	t <sub>TSD_POS1</sub>		154		°C	
Negative Edge	t <sub>TSD_NEG1</sub>		135		°C	
<b>Secondary Side TSD</b>						
Positive Edge	t <sub>TSD_POS2</sub>		150		°C	
Negative Edge	t <sub>TSD_NEG2</sub>		130		°C	
<b>Isolated Temperature Sensor</b>						
Temperature Sense Bias Current Source	I <sub>T1</sub>	0.938	1.015	1.092	mA	TS1 = 2.2 V
	I <sub>T2</sub>	0.953	1.03	1.107	mA	TS2 = 2.2 V
Temperature Sense Current Matching	I <sub>T_MATCH</sub>		0.014	0.0415	mA	TSx = 2.2 V

Parameter	Symbol	Min	Typ	Max	Unit	Test Conditions/Comments
Pulse-Width Modulation (PWM) Output Frequency	f <sub>PWM</sub>	9.20	10	10.80	kHz	PWM_OSC = 0, TS <sub>x</sub> = 2.2 V
		46	50	54	kHz	PWM_OSC = 1, TS <sub>x</sub> = 2.2 V
PWM Duty Cycle		7.50	10	11.3	%	PWM_OSC = 0
		26	28	29.5	%	PWM_OSC = 0
		90.2	92	93.3	%	PWM_OSC = 0
		7.5	10	11.5	%	PWM_OSC = 1
		26	28	29.6	%	PWM_OSC = 1
		90.1	92	93.3	%	PWM_OSC = 1
Overtemperature						
Detect Delay Time	t <sub>DOT</sub>	0.80	1	1.2	ms	
Fault Delay Time	t <sub>DOT_FLT</sub>	530	735	940	ns	
Detection Voltage		1.62	1.69	1.73	V	OT_FAULT_SEL = 0
		1.63	1.73	1.81	V	OT_FAULT_SEL = 1
		1.57	1.65	1.70	V	OT_FAULT_SEL = 0
		1.59	1.69	1.78	V	OT_FAULT_SEL = 1
Low Temperature Threshold		2.35	2.4	2.45	V	TS1 pin voltage
		2.31	2.36	2.41	V	TS1 pin voltage
TEMP_OUT Resistance			11.3	20	Ω	TEMP_OUT current (I <sub>TEMP_OUT</sub> ) = 5 mA
			13.7	23	Ω	I <sub>TEMP_OUT</sub> = 5 mA
Miller Clamp Voltage Threshold	V <sub>MILLER</sub>	1.9	2	2.1	V	Referenced to GND <sub>2</sub>
Internal Turn Off NFET						
On Resistance	R <sub>DSON_N</sub>		0.5	1	Ω	V <sub>OUT_OFF</sub> current (I <sub>VOUT_OFF</sub> ) = 0.5 A, V <sub>DD1</sub> = 6 V, V <sub>DD2</sub> = 12 V
On Resistance 2 Level	R <sub>DSON_N_2LEV</sub>		1.8	4	Ω	I <sub>VOUT_OFF</sub> = 0.1 A, V <sub>DD1</sub> = 6 V, V <sub>DD2</sub> = 12 V
Internal Turn On PFET						
On Resistance	R <sub>DSON_P</sub>		0.6	1.2	Ω	V <sub>OUT_ON</sub> current (I <sub>VOUT_ON</sub> ) = 0.5 A, V <sub>DD1</sub> = 6 V, V <sub>DD2</sub> = 12 V
On Resistance 2 Level	R <sub>DSON_P_2LEV</sub>		2.0	4	Ω	I <sub>VOUT_ON</sub> = 0.1 A, V <sub>DD1</sub> = 6 V, V <sub>DD2</sub> = 12 V
Miller Pull-Down NFET	R <sub>DSON_MILLER</sub>		4.2	10	Ω	Miller current (I <sub>MILLER</sub> ) = 10 mA
V <sub>OFF_SOFT</sub> R <sub>DSON</sub>	R <sub>DSON_SOFT_OFF</sub>		15	36	Ω	V <sub>OFF_SOFT</sub> current (I <sub>OFF_SOFT</sub> ) = 10 mA
Peak Current	I <sub>PEAKIP</sub>		6		A	V <sub>DD2</sub> = 15 V, 2 Ω external resistance
Two-Level Plateau Voltage	V <sub>2LEV</sub>	11.30	11.90	12.50	V	
CURRENT LIMIT						
Set Current	I <sub>L_SENSE</sub>	18	20	22	μA	I <sub>SENSE</sub> = 0.5 V
Internal Current-Limit Reference	V <sub>L_SENSE</sub>	480	500	520	mV	Rising edge
Current-Limit Blanking Time	t <sub>CL_BLANK</sub>	120	145	180	ns	
SWITCHING SPECIFICATIONS						
Pulse Width <sup>1</sup>	PW	74			ns	No load, Miller clamp open
Propagation Delay		71	95	130	ns	No load, Miller clamp open
		79	100	121	ns	No load, Miller clamp open

<sup>1</sup> The minimum pulse width is the shortest pulse width at which the specified timing parameter is guaranteed.

<sup>2</sup> t<sub>DLH</sub> propagation delay is measured from the time of the input rising logic high threshold, V<sub>IH</sub>, to the output rising 0% level of the V<sub>OUT\_ON</sub> or V<sub>OUT\_OFF</sub> signal. t<sub>DHL</sub> propagation delay is measured from the input falling logic low threshold, V<sub>IL</sub>, to the output falling 90% threshold of the V<sub>OUT\_ON</sub> or V<sub>OUT\_OFF</sub> signal. See Figure 13 for waveforms of propagation delay parameters.

### SPI TIMING SPECIFICATIONS

SPI timing specifications are guaranteed by design. All devices are production tested with 200 kHz SPI communication.

Table 2.

Parameter	Description	Min	Typ	Max	Unit
$t_s$	Time to first clock edge	8			$\mu s$
$t_{DS}$	Set period	1			$\mu s$
$t_{DH}$	Hold period	1			$\mu s$
$t_{CLK}$	Clock period	5			$\mu s$
$t_H$	Release time	8			$\mu s$
$t_{HIGH}$	Clock time high	100			ns
$t_{LOW}$	Clock time low	100			ns
$t_{OV}$	Output valid time			240	ns

### SPI Timing Diagram

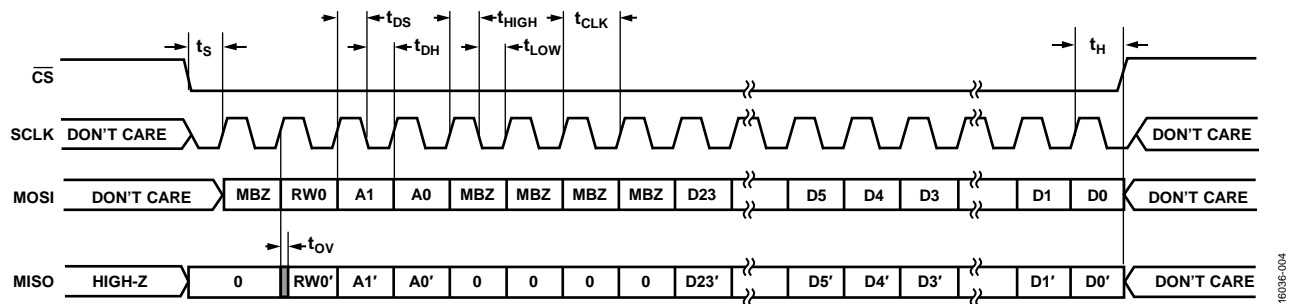

Figure 2. SPI Timing Diagram

### PACKAGE CHARACTERISTICS

Table 3.

Parameter	Symbol	Min	Typ	Max	Unit
Resistance (Input Side to High-Side Output) <sup>1</sup>	$R_{I-O}$		$10^{12}$		$\Omega$
Capacitance (Input Side to High-Side Output) <sup>1</sup>	$C_{I-O}$		2		pF
Input Capacitance	$C_I$		4		pF

<sup>1</sup> The device is considered a two terminal device: Pin 1 through Pin 14 are shorted together, and Pin 15 through Pin 28 are shorted together.

**REGULATORY INFORMATION (PENDING)**

Table 4.

UL (Pending)	CSA (Pending)	VDE (Pending)	CQC (Pending)
UL1577 Component Recognition Program Single Protection, 5000 V rms Isolation Voltage	Approved under CSA Component Acceptance Notice 5A CSA 60950-1-07+A1+A2 and IEC 60950-1, second edition, +A1+A2: Basic insulation at 830 V rms (1174 V <sub>PEAK</sub> ) Reinforced insulation at 415 V rms (587 V <sub>PEAK</sub> ) IEC 60601-1 Edition 3.1: Basic insulation (1 MOPP), 519 V rms (734 V <sub>PEAK</sub> ) Reinforced insulation (2 MOPP), 261 V rms (369 V <sub>PEAK</sub> ) CSA 61010-1-12 and IEC 61010-1 third edition Basic insulation, 300 V rms mains, 830 V secondary (1174 V <sub>PEAK</sub> ) Reinforced insulation, 300 V rms mains, 415 V secondary (587 V <sub>PEAK</sub> )	DIN V VDE V 0884-10 (VDE V 0884-10):2006-12 Reinforced insulation, 849 V <sub>PEAK</sub> , V <sub>OTM</sub> = 8 kV <sub>PEAK</sub>	Certified under CQC11-471543-2012 GB4943.1-2011  Basic insulation, 830 V rms (1174 V <sub>PEAK</sub> ) Reinforced insulation, 415 V rms (587 V <sub>PEAK</sub> )
File E214100	File 205078	File 2471900-4880-0001	File (pending)

**INSULATION AND SAFETY-RELATED SPECIFICATIONS**

Table 5.

Parameter	Symbol	Value	Unit	Test Conditions/Comments
Rated Dielectric Insulation Voltage		5000	V rms	1 minute duration
Minimum External Air Gap (Clearance)	L (I01)	8.3	mm min	Measured from input terminals to output terminals, shortest distance through air
Minimum External Tracking (Creepage)	L (I02)	8.3	mm min	Measured from input terminals to output terminals, shortest distance path along body
Minimum Clearance in the Plane of the Printed Circuit Board (PCB Clearance)	L (PCB)	8.7	mm min	Measured from input terminals to output terminals, shortest distance through air, line of sight, in the PCB mounting plane
Minimum Internal Gap (Internal Clearance)		0.017	mm min	Insulation distance through insulation
Tracking Resistance (Comparative Tracking Index) Material Group	CTI	>400 II	V	DIN IEC 112/VDE 0303 Part 1 Material group (DIN VDE 0110, 1/89, Table 1)



**DIN V VDE V 0884-10 (VDE V 0884-10):2016-12 INSULATION CHARACTERISTICS (PENDING)**

These isolators are suitable for reinforced isolation only within the safety limit data. Protective circuits ensure the maintenance of the safety data. The asterisk (\*) marking on the package denotes DIN V VDE V 0884-10 approval for a 560 V<sub>PEAK</sub> working voltage.

**Table 6. VDE Characteristics**

Description	Test Conditions/Comments	Symbol	Characteristic	Unit
Installation Classification per IEC 60664-1 For Rated Mains Voltage ≤ 150 V rms For Rated Mains Voltage ≤ 300 V rms For Rated Mains Voltage ≤ 600 V rms Climatic Classification Pollution Degree per DIN VDE 0110, Table 1			I to IV I to IV I to IV 40/125/21 2	
Maximum Working Insulation Voltage		V <sub>IORM</sub>	849	V <sub>PEAK</sub>
Input to Output Test Voltage, Method B1	V <sub>IORM</sub> × 1.875 = V <sub>pd(m)</sub> , 100% production test, t <sub>ini</sub> = t <sub>m</sub> = 1 sec, partial discharge < 5 pC	V <sub>pd(m)</sub>	1592	V <sub>PEAK</sub>
Input to Output Test Voltage, Method A	V <sub>IORM</sub> × 1.5 = V <sub>pd(m)</sub> , t <sub>ini</sub> = 60 sec, t <sub>m</sub> = 10 sec, partial discharge < 5 pC	V <sub>pd(m)</sub>		
After Environmental Tests Subgroup 1			1274	V <sub>PEAK</sub>
After Input and/or Safety Test Subgroup 2 and Subgroup 3	V <sub>IORM</sub> × 1.2 = V <sub>pd(m)</sub> , t <sub>ini</sub> = 60 sec, t <sub>m</sub> = 10 sec, partial discharge < 5 pC		1019	V <sub>PEAK</sub>
Highest Allowable Overvoltage Impulse	1.2 μs rise time, 50 μs, 50% fall time in air to the preferred sequence	V <sub>IOTM</sub> V <sub>IMPULSE</sub>	8000 8000	V <sub>PEAK</sub> V <sub>PEAK</sub>
Surge Isolation Voltage Basic	V <sub>PEAK</sub> = 12.8 kV, 1.2 μs rise time, 50 μs, 50% fall time	V <sub>IOSM</sub>	9800	V <sub>PEAK</sub>
Surge Isolation Voltage Reinforced	V <sub>PEAK</sub> = 12.8 kV, 1.2 μs rise time, 50 μs, 50% fall time	V <sub>IOSM</sub>	8000	V <sub>PEAK</sub>
Safety Limiting Values	Maximum value allowed in the event of a failure (see Figure 3)			
Maximum Junction Temperature		T <sub>S</sub>	150	°C
Total Power Dissipation at T <sub>A</sub> = 25°C		P <sub>S</sub>	2.0	W
Insulation Resistance at T <sub>S</sub>	Voltage between the input and output (V <sub>io</sub> ) = 500 V	R <sub>S</sub>	>10 <sup>9</sup>	Ω

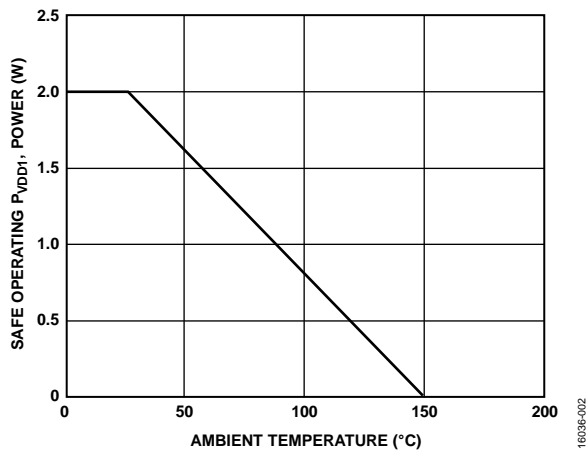

Figure 3. Thermal Derating Curve, Dependence of Safety Limiting Values on Case Temperature, per DIN V VDE V 0884-10

**RECOMMENDED OPERATING CONDITIONS**

**Table 7.**

Parameter	Value
Operating Junction Temperature Range	-40°C to +150°C
Supply Voltages	
V <sub>DD1</sub> Referenced to GND <sub>1</sub>	6.0 V to 25 V
V <sub>DD2</sub> Referenced to GND <sub>2</sub>	12 V to 25 V

## ABSOLUTE MAXIMUM RATINGS

Table 8.

Parameter	Rating
Supply Voltages	
$V_{DD1}$	-0.2 V to +30 V
$V_{DD2}$	-0.2 V to +30 V
Primary Side Pins	
VI+, MOSI, $\overline{CS}$ , SCLK	-0.2 V to +5.5 V
SW, ISENSE, FAULT, TEMP_OUT, PGOOD, MISO	-0.2 V to $V_{5\_1} + 0.2$ V
Secondary Side Pins	
TS1, TS2	-0.2 V to $V_{5\_2} + 0.2$ V
MILLER_OUT, $V_{OFF\_SOFT}$ , $V_{OUT\_OFF}$	-0.2 V to +30 V
$V_{OUT\_ON}$ , DESAT, GATE_SENSE, OC1, OC2	-0.2 V to $V_{DD2} + 0.2$ V
Common-Mode Transients ( $I_{CM}$ )	-150 kV/ $\mu$ s to +150 kV/ $\mu$ s
Storage Temperature Range ( $T_{ST}$ )	-55°C to +150°C
Operating Junction Temperature Range	-40°C to +150°C
Electrostatic Discharge (ESD)	
Human Body Model (HBM)	$\pm 1$ kV
Charge Device Model (CDM)	$\pm 1.25$ kV

Stresses at or above those listed under Absolute Maximum Ratings may cause permanent damage to the product. This is a stress rating only; functional operation of the product at these or any other conditions above those indicated in the operational section of this specification is not implied. Operation beyond the maximum operating conditions for extended periods may affect product reliability.

Table 10. Maximum Continuous Working Voltage<sup>1, 2, 3</sup>

Parameter	Rating	Constraint
AC Voltage		
Bipolar Waveform		
Basic Insulation	849 V <sub>PEAK</sub>	Lifetime limited by insulation lifetime per VDE-0884-11
Reinforced Insulation	707 V <sub>PEAK</sub>	Lifetime limited by insulation lifetime per VDE-0884-11
Unipolar Waveform		
Basic Insulation	1697 V <sub>PEAK</sub>	Lifetime limited by insulation lifetime per VDE-0884-11
Reinforced Insulation	892 V <sub>PEAK</sub>	Lifetime limited by package creepage per IEC 60664-1
DC Voltage		
Basic Insulation	1092 V <sub>PEAK</sub>	Lifetime limited by package creepage per IEC 60664-1
Reinforced Insulation	546 V <sub>PEAK</sub>	Lifetime limited by package creepage per IEC 60664-1

<sup>1</sup> See the Insulation Lifetime section for details.

<sup>2</sup> Other pollution degree and material group requirements yield a different limit.

<sup>3</sup> Some system level standards allow components to use the printed wiring board (PWB) creepage values. The supported dc voltage may be higher for those standards.

Table 11. Truth Table (Positive Logic)

VI+ Input	FAULT Pin	V <sub>DD1</sub> State	V <sub>DD2</sub> State	GATE_SENSE Voltage (V <sub>GATE_SENSE</sub> )
Low	High	Powered	Powered	Low
High	High	Powered	Powered	High
Don't Care or Unknown	Low	Powered	Powered	Low
Don't Care or Unknown	Don't care or unknown	Unpowered	Powered	Low
Don't Care or Unknown	Low	Powered	Unpowered	High-Z

## THERMAL RESISTANCE

Thermal performance is directly linked to PCB design and operating environment. Careful attention to PCB thermal design is required.

$\theta_{JA}$  is the junction to ambient thermal resistance, and  $\Psi_{JT}$  is the junction to top characterization parameter.

Table 9. Thermal Resistance

Package Type <sup>1</sup>	$\theta_{JA}$	$\Psi_{JT}$	Unit
RN-28-1	62.4	2.97	°C/W

<sup>1</sup> 4-layer PCB.

## ESD CAUTION



**ESD (electrostatic discharge) sensitive device.** Charged devices and circuit boards can discharge without detection. Although this product features patented or proprietary protection circuitry, damage may occur on devices subjected to high energy ESD. Therefore, proper ESD precautions should be taken to avoid performance degradation or loss of functionality.

## PIN CONFIGURATION AND FUNCTION DESCRIPTIONS

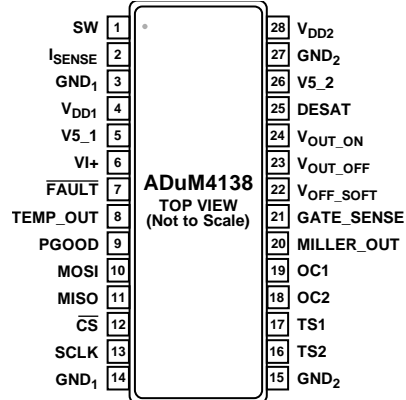

Figure 4. Pin Configuration

Table 12. Pin Function Descriptions

Pin No.	Mnemonic	Description
1	SW	Switching Signal Pin for Isolated Flyback Converter. Connect this pin to the flyback transformer MOSFET.
2	I <sub>SENSE</sub>	Flyback Current Sense. Current sense node for flyback transistor.
3	GND <sub>1</sub>	Ground Reference for Primary Side. Decouple this pin to V <sub>DD1</sub> .
4	V <sub>DD1</sub>	Input Supply Voltage Pin on Primary Side, 6 V to 25 V Referenced to GND <sub>1</sub> .
5	V5_1	5 V Regulated Output. Connect this pin to a 1 $\mu$ F external capacitor referenced to GND <sub>1</sub> . This pin controls the logic levels for the input pins.
6	VI+	Noninverting Input for Gate Drive. Connect this pin to the incoming PWM control signal.
7	FAULT	Fault Reporting Pin. The FAULT pin goes low when an overcurrent event is detected by the overcurrent pin, desaturation is detected, secondary UVLO occurs during thermal shutdown, during remote sensing overtemperature, or during gate voltage low errors.
8	TEMP_OUT	Remote Temperature Sense Reporting Pin. This pin is 10 kHz or 50 kHz and is the 5% to 95% PWM output for the diode temperature sensor.
9	PGOOD	Power Good Pin. The signal is high when the output voltage is within regulation. When not in use, leave this pin open.
10	MOSI	Master Out, Slave In Pin. This pin provides the MOSI connection for the SPI bus.
11	MISO	Master In, Slave Out Pin. This pin provides the MISO connection for the SPI bus.
12	$\overline{CS}$	Chip Select for SPI Bus. Logic is active low.
13	SCLK	Clock for SPI Bus. Connect this pin to the clock pin from the SPI master.
14	GND <sub>1</sub>	Ground Reference for Primary Side.
15	GND <sub>2</sub>	Secondary Ground Reference. Use this ground pin for the high current path.
16	TS2	Remote Temperature Sensor 2. Float or pull this pin high to V5_2 when not in use.
17	TS1	Remote Temperature Sensor 1. See the Applications Information section for more information if this pin is unused.
18	OC2	Split Emitter Overcurrent Detection 2. Connect this pin to GND <sub>2</sub> when this pin is not in use.
19	OC1	Split Emitter Overcurrent Detection 1. Connect this pin to GND <sub>2</sub> when this pin is not in use.
20	MILLER_OUT	Output Signal to Control External MOSFET for Miller Clamping.
21	GATE_SENSE	Miller Clamping Sense Pin. Connect this pin directly to the gate of the IGBT.
22	V <sub>OFF_SOFT</sub>	Soft Shutdown Gate Connection. Connect this pin to the gate through the external series resistor. This pin pulls the gate down during fault conditions.
23	V <sub>OUT_OFF</sub>	Turns Off Current Path Connection. Connect this pin to the gate through the external series resistor. This pin pulls the gate down during the low output command.
24	V <sub>OUT_ON</sub>	Turns On Current Path Connection. Connect this pin to the gate through the external series resistor. This pin pulls the gate up during the high output command.
25	DESAT	Desaturation Detection Pin. Connect this pin to GND <sub>2</sub> when not in use.
26	V5_2	5 V Regulated Output on Secondary Side. Connect this pin to the 1 $\mu$ F external capacitor referenced to GND <sub>2</sub> .
27	GND <sub>2</sub>	Ground Reference for Secondary Side.
28	V <sub>DD2</sub>	Input Supply Voltage on Secondary Side, 15 V (Typical) Referenced to GND <sub>2</sub> .

# TYPICAL PERFORMANCE CHARACTERISTICS

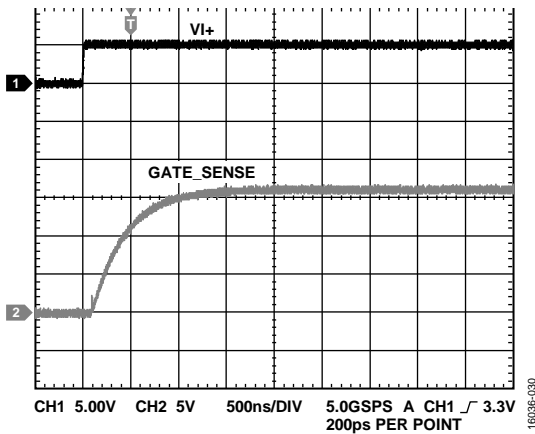

Figure 5. Example Turn On Edge,  $V_{DD1} = 12\text{ V}$ ,  $V_{DD2} = 16\text{ V}$ ,  $3\ \Omega$  Turn On,  $100\text{ nF}$  Load

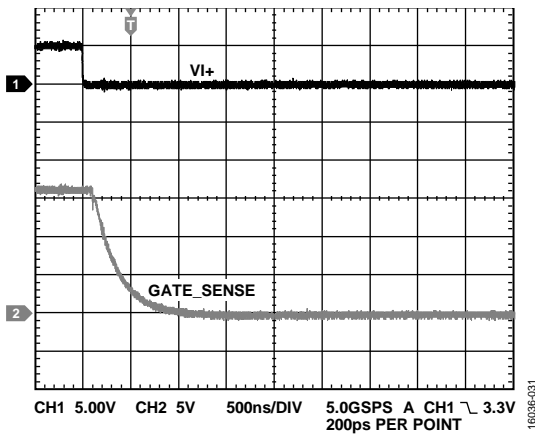

Figure 6. Example Turn Off Edge,  $V_{DD1} = 12\text{ V}$ ,  $V_{DD2} = 16\text{ V}$ ,  $2\ \Omega$  Turn Off,  $100\text{ nF}$  Load

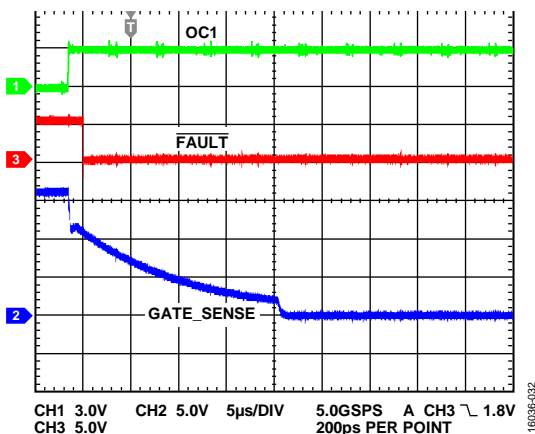

Figure 7. Example Overcurrent Fault,  $V_{DD1} = 12\text{ V}$ ,  $V_{DD2} = 16\text{ V}$ ,  $V_{I+} = 5\text{ V}$ ,  $2\ \Omega$  Turn Off,  $100\text{ nF}$  Load

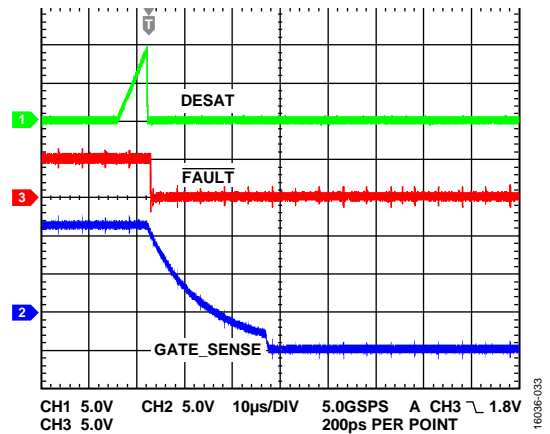

Figure 8. Example DESAT Fault,  $V_{DD1} = 12\text{ V}$ ,  $V_{DD2} = 16\text{ V}$ ,  $V_{I+} = 5\text{ V}$ ,  $2\ \Omega$  Turn Off,  $100\text{ nF}$  Load

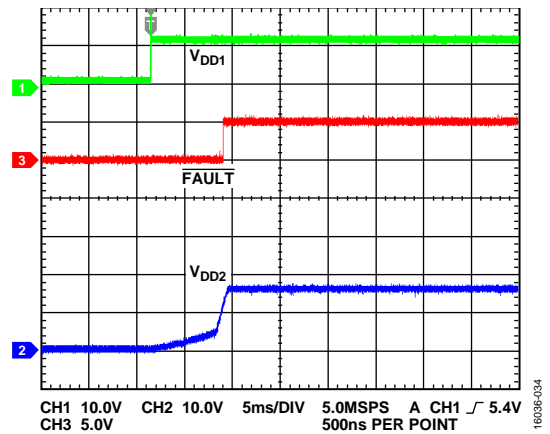

Figure 9. Typical Flyback Startup,  $V_{DD1} = 12\text{ V}$

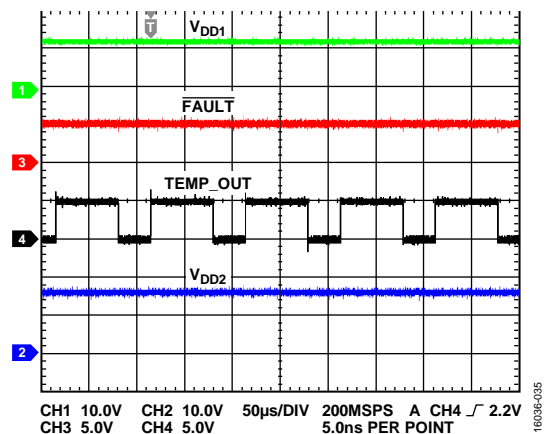

Figure 10. Example TEMP\_OUT Reading,  $V_{DD1} = 12\text{ V}$ ,  $V_{DD2} = 16\text{ V}$

## THEORY OF OPERATION

Gate drivers are required in situations where fast rise times of switching device gates are required. The gate signals for enhancement power devices are referenced to a source or emitter node. The gate driver must follow this source or emitter node. As such, isolation is necessary between the controlling signal and the output of the gate driver in topologies where the source or emitter nodes swing, such as a half bridge. Gate switching times are a function of the drive strength of the gate driver. Buffer stages before a complementary metal-oxide semiconductor (CMOS) output reduce the total delay time and increase the final drive strength of the driver.

The ADuM4138 achieves isolation between the control side and the output side of the gate driver using a high frequency carrier that transmits data across the isolation barrier with *iCoupler*

chip scale transformer coils separated by layers of polyimide isolation. The ADuM4138 uses positive logic on/off keying (OOK) encoding, in which a high signal is transmitted by the presence of the carrier frequency across the *iCoupler* chip scale transformer coils. Positive logic encoding ensures that a low signal is seen on the output when the input side of the gate driver is unpowered. A low state is the most common safe state in enhancement mode power devices and can drive in situations where shoot through conditions are present. The architecture of the ADuM4138 is designed for high common-mode transient immunity and high immunity to electrical noise and magnetic interference. Radiated emissions are minimized with a spread spectrum OOK carrier and differential coil layout. Figure 11 shows the OOK encoding used by the ADuM4138.

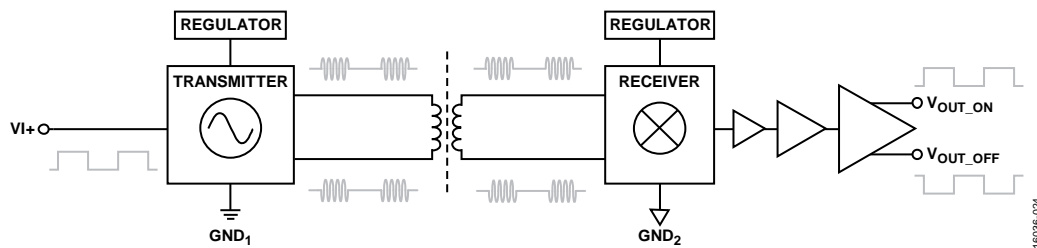

Figure 11. Operational Block Diagram of OOK Encoding

## APPLICATIONS INFORMATION

### PCB LAYOUT

The ADuM4138 IGBT gate driver requires no external interface circuitry for the logic interfaces. Power supply bypassing is required at the  $V_{DD1}$  and  $V_{DD2}$  supply pins. Use a small ceramic capacitor ( $>10 \mu\text{F}$ ) from  $V_{DD1}$  to GND<sub>1</sub>. Add at least  $30 \mu\text{F}$  to  $60 \mu\text{F}$  capacitance on the output power supply pin ( $V_{DD2}$ ) to provide the charge required to drive the gate capacitance at the outputs. This capacitance can be provided by multiple parallel capacitors. Avoid using vias on  $V_{DD2}$  on the bypass capacitor or employing multiple vias to reduce the inductance in bypassing because board vias can introduce parasitic inductance. The total lead length between both ends of the smaller capacitor and the input or output power supply pin must not exceed approximately 5 mm. For the 5 V regulators, place  $1 \mu\text{F}$  capacitors as close as possible to the ADuM4138.

### ISOLATED FLYBACK CONTROLLER

The ADuM4138 has an integrated isolated flyback controller that delivers isolated power to the gate being driven. The flyback controller provides a control signal to the flyback MOSFET on the low side of the device. This MOSFET switches the primary side of the flyback transformer. An external diode rectifies the secondary voltage and regulates the internal compensation on the secondary side. An inductive isolation link transfers duty cycle information to the primary side.

Startup includes a soft start, where the duty cycle is controlled to a maximum value that increases with time. The primary side has an oscillator that controls this timing. The secondary side also has an oscillator, creating the 200 kHz (typical) ramp signal used to create the PWM control. The handoff between the soft start and secondary oscillator is controlled internally without user intervention. An internal resistor network performs feedback sensing on the  $V_{DD2}$  pin.

The power good pin, PGOOD, is available for output on the primary side, allowing the user to observe when the secondary voltage is within regulation.

If  $V_{DD2}$  loses power during operation, a fault posts to the primary side, and the flyback does not automatically attempt recovery. The  $V_{DD1}$  power cycle initiates the flyback operation again.

Peak current mode control is employed on the primary side of the ADuM4138 through the  $I_{SENSE}$  pin. Use the following equation to set the current limit:

$$I_{PEAK} \text{ (mA)} = 100 \text{ mV}/R_S \quad (1)$$

where:

$I_{PEAK}$  is the desired peak current limit in mA.

$R_S$  is the sense resistor used to set the peak current limit in  $\Omega$ .

A typical application is shown in Figure 30. The recommended current-limit resistance ( $R_{CL}$ ) value is 20 k $\Omega$ . In operation, the equation for setting the peak current follows:

$$V_{L\_SENSE} = (I_{L\_SENSE}) \times (R_{CL}) + (I_{PEAK}) \times (R_S) \quad (2)$$

where:

$V_{L\_SENSE} = 500 \text{ mV}$  (typical)

$I_{L\_SENSE} = 20 \mu\text{A}$  (typical)

$R_{CL} = 20 \text{ k}\Omega$  (recommended)

### SPI AND EEPROM OPERATION

#### SPI Programming

The ADuM4138 contains an SPI bus for setting remote temperature gains and offsets, PWM reporting frequency, high temperature faults, and low temperature operation mode. The SPI bus allows programming of the secondary side EEPROM, allowing a permanent operation setting. The SPI interface can operate in a daisy-chain mode to allow efficient use of the microcontroller input and output pins. When the chip select ( $\overline{\text{CS}}$ ) pin is brought low, programming of the EEPROM is available. However, the gate drive output is disabled. The gate drive output is not available again until  $\overline{\text{CS}}$  is brought back to high.

Programming is performed using the standard SPI convention of clock polarity (CPOL) = 0 and clock phase (CPHA) = 1. The SPI timing diagram shown in Figure 2 demonstrates a typical read or write operation. Bit A1 and Bit A0 are the address bits. The must be zero (MBZ) bits must be set to 0. Bits[D23:D0] are the data bits, with MSB first. Bit RW0 sets whether the action is a read (0) or a write (1).

## USER REGISTER MAP

Figure 12 shows the user register map and binary addresses.

ADDRESS	NAME	BIT																												
		23	22	21	20	19	18	17	16	15	14	13	12	11	10	9	8	7	6	5	4	3	2	1	0					
00	USER	OFFSET_2[5:0]						GAIN_2[5:0]						OFFSET_1[5:0]						GAIN_1[5:0]										
01	CONFIG	RESERVED														OT_FAULT_OP	OT_FAULT_SEL	OC_TIME_OP	OC_2LEV_OP	LOW_T_OP	OC_BLANK_OP	t <sub>BLANK</sub> [0:3]			ECC_OFF_OP	FLYBACK_V[3:0]			T_RAMP_OP	PWM_OSC
10	CONTROL	RESERVED																		ECC2_DBL_ERR	ECC2_SNG_ERR	ECC1_DBL_ERR	ECC1_SNG_ERR	PROG_BUSY	SIM_TRIM					

Figure 12. User Register Map

## USER REGISTER BITS

Table 13 lists the user register (Address 00) bits and bit descriptions.

Table 13. User Register (Address 00) Bit Descriptions

Bits	Bit Name	Description
[23:18]	OFFSET_2[5:0]	TS2 offset
[17:12]	GAIN_2[5:0]	TS2 gain
[11:6]	OFFSET_1[5:0]	TS1 offset
[5:0]	GAIN_1[5:0]	TS1 gain

### OFFSET\_2[5:0] Bits

Use the OFFSET\_2 bits of the EEPROM to adjust the internal offset for the TS2 pin.

### GAIN\_2[5:0] Bits

Use the GAIN\_2 bits of the EEPROM to adjust the internal gain for the TS2 pin.

### OFFSET\_1[5:0] Bits

Use the OFFSET\_1 bits of the EEPROM to adjust the internal offset for the TS1 pin.

### GAIN\_1[5:0] Bits

Use the GAIN\_1 bits of the EEPROM to adjust the internal gain for the TS1 pin.

## CONFIGURATION REGISTER BITS

Table 14 lists the configuration (CONFIG) register (Address 01) bits and bit descriptions.

Table 14. CONFIG Register (Address 01) Bit Descriptions

Bit Name	Bits	Description
Reserved	[23:17]	Reserved
OT_FAULT_OP	16	Overtemperature fault disable
OT_FAULT_SEL	15	Overtemperature fault select
OC_TIME_OP	14	Disable two-level drive and timer during overcurrent event
OC_2LEV_OP	13	Overcurrent two-level operation select
LOW_T_OP	12	Low temperature operation select

Bit Name	Bits	Description
OC_BLANK_OP	11	Overcurrent blanking operation select
t <sub>BLANK</sub> [3:0]	[10:7]	Overcurrent blanking time
ECC_OFF_OP	6	Enable soft shutdown with error correcting code (ECC) fault
FLYBACK_V[3:0]	[5:2]	Flyback output voltage setting
T_RAMP_OP	1	Overcurrent temperature ramp enable
PWM_OSC	0	Temperature reading output oscillator select

### OT\_FAULT\_OP Bit

Set the OT\_FAULT\_OP bit to 1 to disable a fault for over-temperature. If this bit is set to 0, the ADuM4138 issues a fault when the TS1 or TS2 pin detects an overtemperature event.

### OT\_FAULT\_SEL Bit

The OT\_FAULT\_SEL bit selects between two overtemperature fault voltage thresholds. Set this bit to 0 to set the falling threshold to 1.65 V (typical) and the rising threshold is 1.69 V (typical). Set the OT\_FAULT\_SEL bit to 1 to set the falling threshold to 1.69 V (typical) and the rising threshold is 1.73 V (typical).

### OC\_TIME\_OP Bit

Set the OC\_TIME\_OP bit to 1 to disable the two-level drive and timer during an overcurrent event. During an overcurrent event, the output immediately enters soft shutdown. If enabled, overcurrent blanking is still available.

### OC\_2LEV\_OP Bits

Set the OC\_2LEV\_O bit to 1 to disable the two-level drive during an overcurrent event before a fault registers. After the overcurrent detection time completes, a fault registers and the output shuts down using the soft shutdown. If this bit is set to 0 during an overcurrent event, but before t<sub>dOC</sub>, the two-level drive level is output to the gate.

**LOW\_T\_OP Bit**

Bit 12 of the CONFIG register can disable a special low temperature operation. If the LOW\_T\_OP bit is set to 0 when the TS1 pin rises above 2.4 V (typical), the gate voltage goes to the two-level plateau voltage during an on command. Hysteresis allows operation down to 2.36 V (typical) on TS1 before the low temperature operation mode is left. If the LOW\_T\_OP bit is set to 1, all nonfault gate signals are at the  $V_{DD2}$  output voltage on an on signal.

**OC\_BLANK\_OP Bit**

Set the OC\_BLANK\_OP bit to 1 to enable the two-level drive during the current blanking time. When the OC\_BLANK\_OP bit is set to 1, it enters the two-level drive in case of an overcurrent event during the blanking time,  $t_{BLANK}$ .

 **$t_{BLANK}[3:0]$  Bits**

During the initial turn on of a gate, a large amount of noise caused by switching actions can exist. To account for this noise, the overcurrent detection can be masked by setting different  $t_{BLANK}$  values. During the masking time, overcurrent events are ignored.

**Table 15.  $t_{BLANK}$  Blanking Times**

$t_{BLANK}[3:0]$ , Bits[10:7]	Blanking Time ( $\mu$ s) Typical
0000	0
0001	0.36
0010	0.56
0011	0.77
0100	0.97
0101	1.17
0110	1.57
0111	1.97
1000	2.37
1001	2.78
1010	3.18
1011	3.58
1100	3.98
1101	4.39
1110	4.79
1111	5.19

**ECC\_OFF\_OP Bit**

If the ECC\_OFF\_OP bit is set to 1 when an ECC error is detected, the ADuM4138 enters a soft shutdown and a fault registers. This fault registers whether a single or double ECC fault is detected. If this bit is set to 0, ECC faults are set in the control register (Address 10), but the ADuM4138 continues to operate without shutting down.

**FLYBACK\_V[3:0] Bits**

The FLYBACK\_V bits in the EEPROM can set the isolated flyback output voltage. The default code is 0111 (16.00 V target). Table 16 describes the output voltages available.

**Table 16. EEPROM Register Map**

FLYBACK_V[3:0]	$V_{DD2}$ Voltage Setting (V)
0000	14.25
0001	14.50
0010	14.75
0011	15.00
0100	15.25
0101	15.50
0110	15.75
0111 (Default)	16.00
1000	16.25
1001	16.50
1010	16.75
1011	17.00
1100	17.25
1101	17.50
1110	17.75
1111	20.00

**T\_RAMP\_OP Bit**

Set the T\_RAMP\_OP bit to 0 to allow the overcurrent reference voltage to vary with temperature. The current reference varies by 10% across the TS1 voltages of 1.55 V to 2.45 V, as shown in Figure 14. Set the T\_RAMP\_OP bit to 1 to have the overcurrent reference voltage,  $V_{OCD\_TH}$ , set to 2 V (typical) regardless of the sensed temperature.

**PWM\_OSC Bit**

The PWM\_OSC bit controls whether the reported TEMP\_OUT pin PWM frequency is 10 kHz or 50 kHz. When the PWM\_OSC bit is set to 0, the output frequency is 10 kHz (typical). When the PWM\_OSC bit is set to 1, the PWM output frequency is 50 kHz (typical).



## CONTROL REGISTER BITS

Table 17 lists the control register (Address 10) bits and bit descriptions.

**Table 17. Control Register (Address 10) Bit Descriptions**

Field	Bit(s)	Description
Reserved	[23:6]	Reserved.
ECC2_DBL_ERR	5	Error Correcting Code Bank 2 double error detected
ECC2_SNG_ERR	4	Error Correcting Code Bank 2 single error detected
ECC1_DBL_ERR	3	Error Correcting Code Bank 1 double error detected
ECC1_SNG_ERR	2	Error Correcting Code Bank 1 single error detected
PROG_BUSY	1	Program/busy bit
SIM_TRIM	0	Simulate trim

### ***ECC2\_DBL\_ERR Bit***

When two errors are detected in the EEPROM stored data, the ECC2\_DBL\_ERR bit sets to 1 when read. Two errors are detectable. However, these errors cannot be fixed using the error correcting code employed by the ADuM4138. The ECC2\_DBL\_ERR bit set to 1 indicates when a double error is detected in the memory banks, representing trim performed on the ADuM4138 outside of the registers affected by user and configuration (CONFIG) addresses. When this bit is set to 0, it indicates no error was detected for bits greater than 1.

### ***ECC2\_SNG\_ERR Bit***

When a single error is detected in the EEPROM stored data, the ECC2\_SNG\_ERR bit sets to 1 when read. The error correcting code employed by the ADuM4138 can detect and correct a single error. The ECC2\_SNG\_ERR bit set to 1 indicates when a single error is detected in the memory banks, representing trim performed on the ADuM4138 outside of the registers affected by user and configuration (CONFIG) addresses. When this bit is set to 0, it indicates no single bit error was detected.

### ***ECC1\_DBL\_ERR Bit***

When two errors are detected in the EEPROM stored data, the ECC1\_DBL\_ERR bit sets to 1 when read. Two errors are detectable. However, these errors cannot be corrected using the error correcting code employed by the ADuM4138. The ECC1\_DBL\_ERR bit set to 1 indicates that a double error is detected in the memory banks, representing trim performed on the ADuM4138 by the user and configuration (CONFIG) addresses. A value of 0 indicates no error was detected for bits greater than 1.

### ***ECC1\_SNG\_ERR Bit***

When a single error is detected in the EEPROM stored data, the ECC1\_SNG\_ERR bit is set to 1 when read. The error correcting code employed by the ADuM4138 can detect and correct a single error. The ECC2\_SNG\_ERR bit set to 1 indicates that a single error is detected in the memory banks, representing trim performed on the ADuM4138 by the user and configuration (CONFIG) addresses. A value of 0 indicates no single bit error was detected.

### ***PROG\_BUSY Bit***

Set the PROG\_BUSY bit high to program the EEPROM memory. When this bit is set to 1, the EEPROM begins to write to the memory. The hardware sets this bit back to 0 to indicate that programming has occurred. The write sequence takes 40 ms (maximum) to perform but can write faster than 40 ms (maximum). If a shorter wait time is required, the PROG\_BUSY bit can be read back multiple times during the write time. If 0 is read back after the user sets this bit to 1, the write completed.

### ***SIM\_TRIM Bit***

If the SIM\_TRIM bit is set to 0, the user and configuration (CONFIG) registers have no effect on the operation of the ADuM4138. Use this bit to simulate trim settings but not to write to the registers.

If SIM\_TRIM is set high, address values can change the operation of the gate driver to simulate what programming the values to the EEPROM does across power ups. When SIM\_TRIM is set to 0, previous address values from the EEPROM are loaded, and operation returns to what the power on state is.

**PROPAGATION DELAY RELATED PARAMETERS**

Propagation delay describes the time it takes a logic signal to propagate through a component. The propagation delay to a low output can differ from the propagation delay to a high output. The ADuM4138 specifies  $t_{DLH}$  (see Figure 13) as the time between the rising input high logic threshold,  $V_{IH}$ , to the output rising 10% threshold. Likewise, the falling propagation delay,  $t_{DHL}$ , is defined as the time between the input falling logic low threshold,  $V_{IL}$ , and the output falling 90% threshold. The rise and fall times are dependent on the loading conditions and are not included in the propagation delay, which is the industry standard for gate drivers.

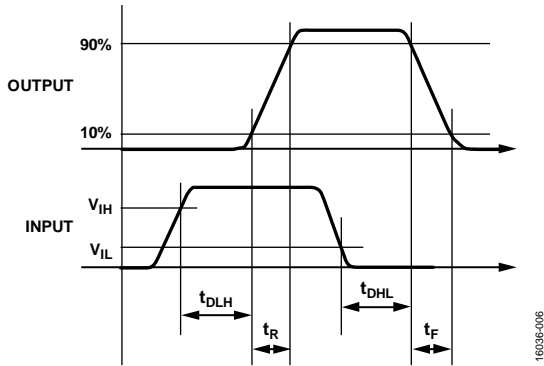

Figure 13. Propagation Delay Parameters

Propagation delay skew refers to the maximum amount that the propagation delay differs between multiple ADuM4138 components operating under the same temperature, input voltage, and load conditions.

**PROTECTION FEATURES**

**Primary Side UVLO**

The ADuM4138 has UVLO on both the primary and secondary sides. If the primary side voltage drops below 4.13 V (typical), the transmission to the secondary side is stopped, effectively bringing the output low. There can be current flowing from the decoupling capacitor on the V5\_1 pin due to the body diode of the 5 V internal regulator. It is recommended that the  $V_{DD1}$  pin to  $GND_1$  pin be supplied with a voltage 6 V or greater.

**Fault Reporting**

The ADuM4138 provides protections for faults that may occur during the operation of an IGBT. The primary fault condition is overcurrent as detected by the overcurrent detection pins, OC1 or OC2. If detected, the ADuM4138 shuts down the gate drive and asserts the FAULT pin low. Faults initiate a soft shutdown through the  $V_{OFF\_SOFT}$  pin. Faults can be initiated by the secondary UVLO, TSD, desaturation detection, overcurrent, gate low voltage detect, and remote overtemperature.

**Overcurrent Detection**

The ADuM4138 operates with split emitter IGBTs or split source MOSFETs. Using the lower current leg of the split leg switches, an accurate measurement of current through the IGBT or MOSFET can be made through a precision sense resistor. In this way, fast reaction to overcurrent events results. When an overcurrent event is detected, a high speed, two-level, turn off initiates. If the overcurrent condition remains beyond the two-level, detect delay time ( $t_{dOC}$ ), a fault reports to the primary side of the ADuM4138. If the overcurrent condition is removed before the turn off time, the  $V_{OUT\_ON}$  pin returns to a high output state, and the fault timer is reset.

Sense temperature on the TS1 pin can modify the overcurrent threshold. If the T\_RAMP\_OP bit is set to 1, the overcurrent threshold is set to 2 V (typical) across all operating conditions. If the T\_RAMP\_OP bit is set to 0, the overcurrent voltage temperature threshold,  $V_{OCD\_TH\_EN}$ , is set to 2.69 V (typical) at  $TS1 = 1.55$  V and goes to 1.75 V (typical) at  $TS1 = 2.45$  V in a linear fashion (see Figure 14).

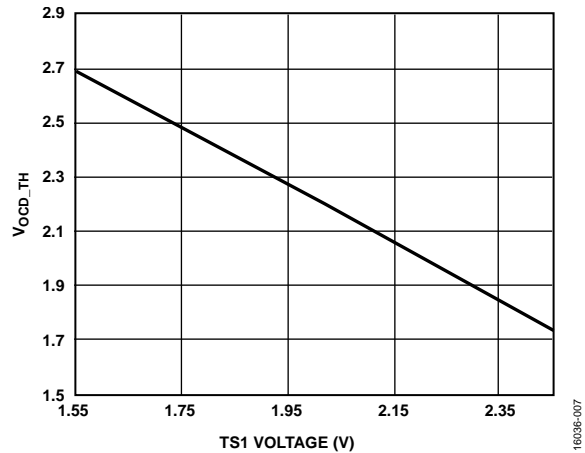

Figure 14. Overcurrent Threshold Variation due to Sensed Temperature

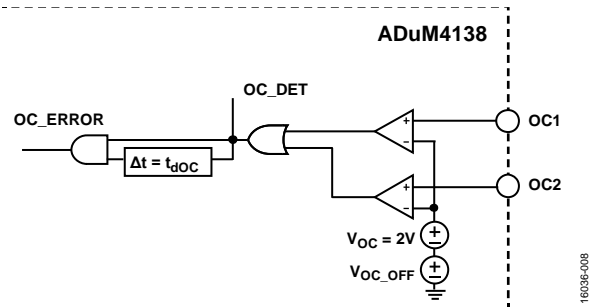

Figure 15. Split Emitter Overcurrent Detection Functional Block Diagram

**High Speed, Two-Level, Turn Off**

If the OC1 or OC2 pin detects an overcurrent, the two-level turn off circuitry drives the gate low. The internal MOSFET drives the device gate low until the input voltage (GATE\_SENSE) reaches the 11.9 V (typical) voltage plateau.  $t_{dOCR}$  is time the output takes from detecting an overcurrent to driving the overcurrent to the plateau voltage. After the detect time ( $t_{dOC}$ ), a fault is registered and reported to the primary side (see Figure 16). If during  $t_{dOC}$  the overcurrent threshold ( $V_{OCD\_TH}$ ), is no longer violated, the internal positive metal-oxide conductor (PMOS) returns the gate back to the  $V_{DD2}$  voltage and the two-level timer is reset (see Figure 17).

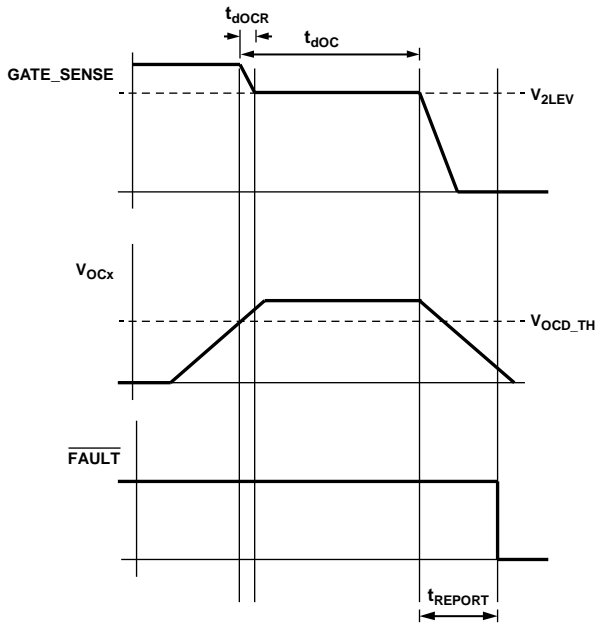

Figure 16. Two-Level Turn Off Fault Example (Not to Scale)

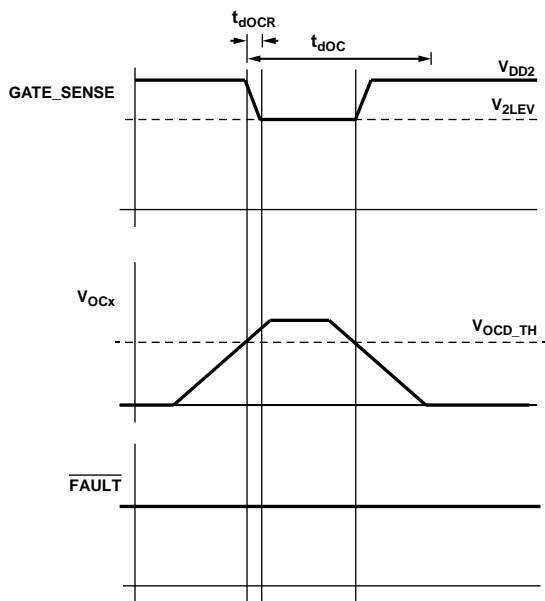

Figure 17. Two-Level Timer Recovery Example (Not to Scale)

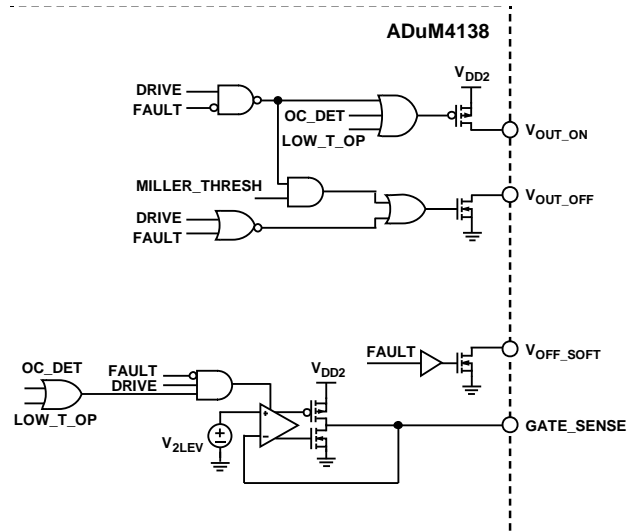

Figure 18. Gate Voltage Output Functional Block Diagram

**Miller Clamp**

The ADuM4138 has an integrated Miller clamp control signal to reduce voltage spikes on the IGBT gate due to the Miller capacitance during shutoff of the IGBT. When the input gate signal calls for the IGBT to turn off (drive low), the external Miller clamp MOSFET signal is initially off. When the voltage on the GATE\_SENSE pin crosses the 2 V (typical) internal voltage reference, as referenced to  $GND_2$ , the Miller clamp latches on for the remainder of the off time of the IGBT, creating a second low impedance current path for the gate current to follow. The Miller clamp switch remains on until the input drive signal changes from low to high. Figure 19 shows an example waveform of this timing, and Figure 20 shows the functional block diagram of the Miller clamp.

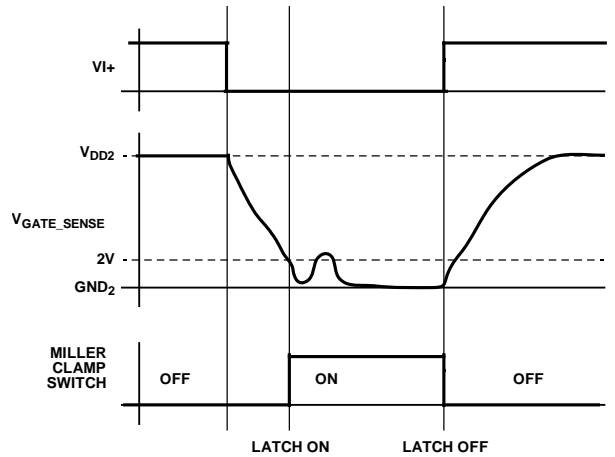

Figure 19. Miller Clamp Example Waveform of Timing

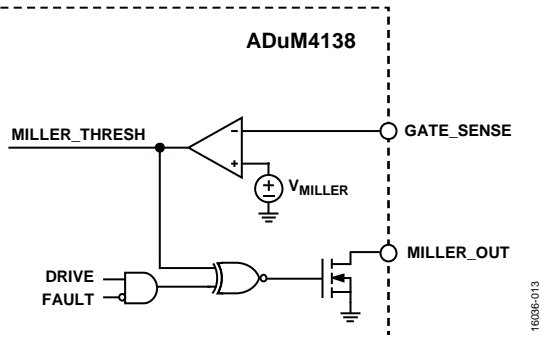

Figure 20. Miller Clamp Functional Block Diagram

**Desaturation Detection**

The ADuM4138 enters a failure state and turns the IGBT off to prevent desaturation from causing a short-circuit condition across the IGBT, if the DESAT pin exceeds the DESAT threshold,  $V_{DESAT\_R}$ , of 8.9 V (typical) while the high-side driver is on. At this time, the FAULT pin is brought low. An internal current source of 490  $\mu$ A (typical) is provided, as well as the option to boost the charging current using external current sources or pull-up resistors. The ADuM4138 has a built in blanking time,  $t_{BLANK}$ , to prevent false triggering while the IGBT is first turning on. The time between desaturation detection and reporting a desaturation fault to the FAULT pin is less than 825 ns (typical).  $t_{DESAT\_BLANK}$  provides a 450 ns (typical) masking time that keeps the internal switch that grounds the blanking capacitor tied low for the initial portion of the IGBT on time, as shown in Figure 21.

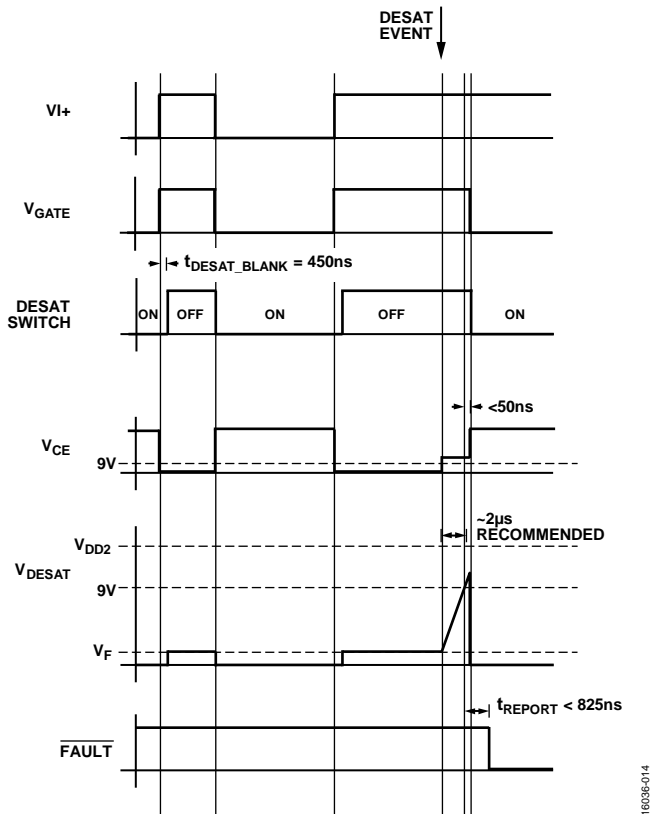

Figure 21. Desaturation Detection Timing Diagram

Under normal operation, during IGBT off times, the voltage across the IGBT ( $V_{CE}$ ) rises to the rail voltage supplied to the system. In this instance, the blocking diode shuts off, protecting the ADuM4138 from high voltages. During the off times, the internal desaturation switch is on, accepting the current going through the  $R_{BLANK}$  resistor, which allows the  $C_{BLANK}$  capacitor to remain at a low voltage. For the first 450 ns (typical) of the IGBT on time, the desaturation switch remains on, clamping the DESAT pin voltage low. After the 450 ns (typical) delay time, the DESAT pin releases, and the DESAT pin rises to starting voltage ( $V3$ ) =  $V_{CE} + V_F + V_{R\_DESAT}$  to dampen the current at this time, usually around 100  $\Omega$  (see Figure 30). Select a blocking diode with fast recovery and suitable blocking voltage.

In the case of a desaturation event,  $V_{CE}$  rises above the 9 V threshold in the desaturation detection circuit. The voltage on the DESAT pin rises with a resistor capacitor (RC) time constant profile dependent on the  $C_{BLANK}$  capacitor and the  $R_{BLANK}$  resistor. The exact timing of this depends on  $V3$ , the supply voltage ( $V_{DD2}$ ), the  $R_{BLANK}$  resistor, and the  $C_{BLANK}$  capacitor values. Depending on the IGBT specifications, a blanking time of around 2  $\mu$ s is the typical design choice. When the DESAT pin rises above the 9 V threshold, a fault registers, and the gate output is driven low. The NFET soft shutdown MOSFET brings the output low, which is 15  $\Omega$  (typical), to perform a soft shutdown to reduce the chance of an overvoltage spike on the IGBT during an abrupt turn off event. Within 825 ns (typical), the fault communicates back to the primary side FAULT pin.

**Thermal Shutdown**

The ADuM4138 contains two thermal shutdowns (TSDs). If the internal temperature of the secondary side of the ADuM4138 exceeds 150°C (typical), the ADuM4138 enters a TSD fault, and the gate drive is disabled by means of a soft shutdown. When a TSD occurs, the ADuM4138 does not leave TSD until the internal temperature has dropped below 130°C (typical). After reaching this temperature, the ADuM4138 exits shutdown. A fault output is available on the primary side during a TSD event on the secondary side by means of the FAULT pin.

If the primary die temperature exceeds 154°C (typical), the primary side functions shut down, stopping the flyback switching and shutting down the secondary side. The primary side leaves TSD when the internal temperature has dropped below 135°C (typical).

The main cause of overtemperature is driving too large a load for a given ambient temperature. This type of temperature overload typically affects the secondary side die because this is where the main power dissipation for load driving occurs.

**Isolated Temperature Sensor**

The ADuM4138 allows simple isolated temperature detection. Using an internal current source to bias an external temperature sensing diode, the ADuM4138 encodes the forward-biased voltage of the diode into a PWM signal, which is passed across the isolation barrier from the secondary side to the primary side. The PWM signal operates at 10 kHz or 50 kHz (programmed in the EEPROM). A 10% (typical) PWM signal corresponds to a voltage of 2.45 V, and a 92% (typical) PWM signal corresponds to 1.55 V. Voltages between the minimum and maximum are approximately linear and monotonically interpolated. The ADuM4138 contains support for two remote temperature sensing diode assemblies, which can both cause overheating faults on the secondary side. Additionally, one temperature sensor readback is available for reading on the primary side through the isolated temperature reporting channel. The lower voltage (higher temperature) of the two temperature sensor pins, TS1 and TS2, reports on the TEMP\_OUT pin. The gain and offset of the PWM temperature sensor can be set in the TEMP\_OUT pin voltage mapping (see Figure 22).

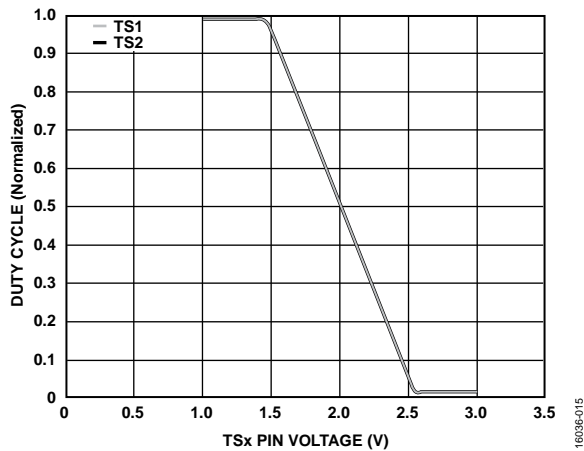

Figure 22. TEMP\_OUT Duty Cycle vs. Lower TSx Pin Voltage

A low temperature operation mode is available if the voltage sensed on the TS1 pin is greater than 2.4 V (typical), the maximum gate voltage is set to the two-level plateau voltage of 11.90 V (typical), see Figure 23. Hysteresis allows continued low temperature operation until the TS1 pin voltage goes below 2.36 V (typical). Low temperature operation can be enabled or disabled in the EEPROM settings in the LOW\_T\_OP bit, Address 01, Bit 12. Basic operation is shown in Figure 23. During the two-level drive, the R<sub>DS(on)</sub> resistances of the turn on and turn off drivers increase to approximately 4 times the normal turn on and turn off resistances.

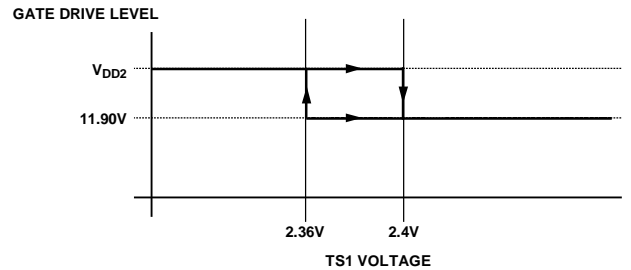

Figure 23. Low Temperature Operation

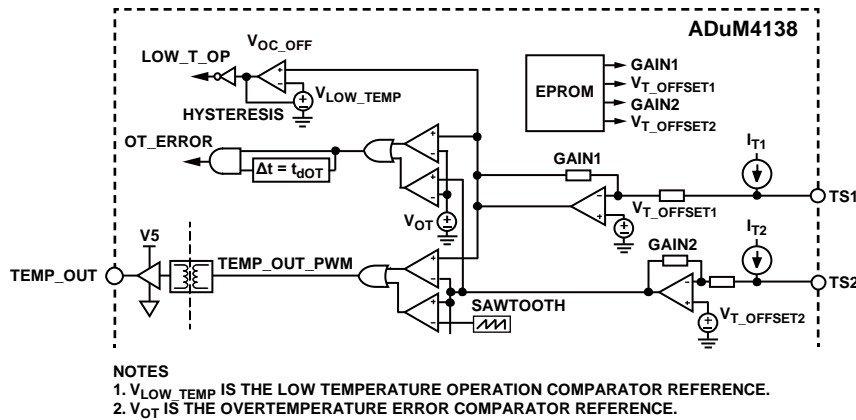

Figure 24. Remote Temperature Sensing Block Diagram

## POWER DISSIPATION

When driving an IGBT gate, the driver must dissipate power. This power can lead to TSD if the following considerations are not made. The gate of an IGBT can be simulated roughly as a capacitive load. Due to Miller capacitance and other nonlinearities, it is common practice to take the stated input capacitance ( $C_{ISS}$ ) of a given IGBT and multiply it by a factor of 5 to arrive at a conservative estimate to approximate the load being driven. With this value, the estimated total power dissipation ( $P_{DISS}$ ) in the system due to switching action is given by the following equation:

$$P_{DISS} = C_{EST} \times (V_{DD2})^2 \times f_s$$

where:

$$C_{EST} = C_{ISS} \times 5.$$

$V_{DD2}$  is the voltage on the  $V_{DD2}$  pin.  $f_s$  is the switching frequency of IGBT.

This power dissipation is shared between the internal on resistances of the internal gate driver switches and the external gate resistances,  $R_{GON}$  and  $R_{GOFF}$ . The ratio of the internal gate resistances to the total series resistance allows the calculation of losses seen within the ADuM4138 chip.

Take the power dissipation found inside the chip due to switching, adding the quiescent power losses, and multiplying it by the  $\theta_{JA}$  gives the rise above ambient temperature that the ADuM4138 experiences.

$$P_{DISS\_ADUM4138} = P_{DISS} \times 0.5(R_{DS(on)_P} \div (R_{GON} + R_{DS(on)_P}) + (R_{DS(on)_N} \div (R_{GOFF} + R_{DS(on)_N})) + P_{QUIESCENT}$$

where:

$P_{DISS\_ADUM4138}$  is the power dissipation of the ADuM4138.

$R_{GON}$  is the external series resistance in the on path.

$R_{GOFF}$  is the external series resistance in the off path.

$P_{QUIESCENT}$  is the quiescent power.

$$T_{ADuM4138} = \theta_{JA} \times P_{DISS\_ADuM4138} + T_{AMB}$$

where:

$T_{ADuM4138}$  is the junction temperature of the ADuM4138.

$T_{AMB}$  is the ambient temperature.

For the ADuM4138 to remain within specification,  $T_{ADuM4138}$  cannot exceed 150°C (typical). When  $T_{ADuM4138}$  exceeds 150°C (typical), the ADuM4138 enters TSD.

## INSULATION LIFETIME

All insulation structures eventually break down when subjected to voltage stress over a sufficiently long period. The rate of insulation degradation is dependent on the characteristics of the voltage waveform applied across the insulation. In addition to the testing performed by the regulatory agencies, Analog Devices carries out an extensive set of evaluations to determine the lifetime of the insulation structure within the ADuM4138.

Analog Devices performs accelerated life testing using voltage levels higher than the rated continuous working voltage. Acceleration factors for several operating conditions are determined. These factors allow calculation of the time to failure at the actual working voltage.

The values shown Table 10 summarize the peak voltage for 20 years of service life for a bipolar ac operating condition, and the maximum CSA/VDE approved working voltages. In many cases, the approved working voltage is higher than the 20 year service life voltage. Operation at these high working voltages can lead to shortened insulation life in some cases.

The insulation lifetime of the ADuM4138 depends on the voltage waveform type imposed across the isolation barrier. The *iCoupler* insulation structure degrades at different rates depending on whether the waveform is bipolar ac, unipolar ac, or dc. Figure 25, Figure 26, and Figure 27 show these different isolation voltage waveforms.

A bipolar ac voltage environment is the worst case for the *iCoupler* products and is the 20 year operating lifetime that Analog Devices recommends for maximum working voltage (see Figure 25). In the case of unipolar ac or dc voltage, the stress on the insulation is significantly lower, which allows operation at higher working voltages while still achieving a 20 year service life. Treat any cross insulation voltage waveform that does not conform to Figure 26 or Figure 27 as a bipolar ac waveform, and limit its peak voltage to the 20 year lifetime voltage value listed in Table 10.

The voltage presented in Figure 26 is shown as sinusoidal for illustration purposes only. It is meant to represent any voltage waveform varying between 0 V and some limiting value. The limiting value can be positive or negative, but the voltage cannot cross 0 V.

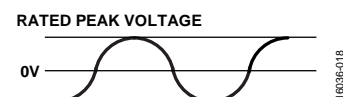

Figure 25. Bipolar AC Waveform

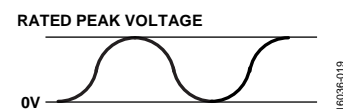

Figure 26. Unipolar AC Waveform

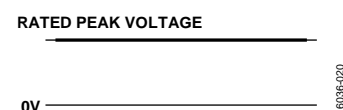

Figure 27. Unipolar DC Waveform

**DC CORRECTNESS AND MAGNETIC FIELD IMMUNITY**

The ADuM4138 is resistant to external magnetic fields. The limitation on the ADuM4138 magnetic field immunity is set by the condition in which the induced voltage in the transformer receiving coil is sufficiently large to either falsely set or reset the decoder. The following analysis defines the conditions under which this can occur.

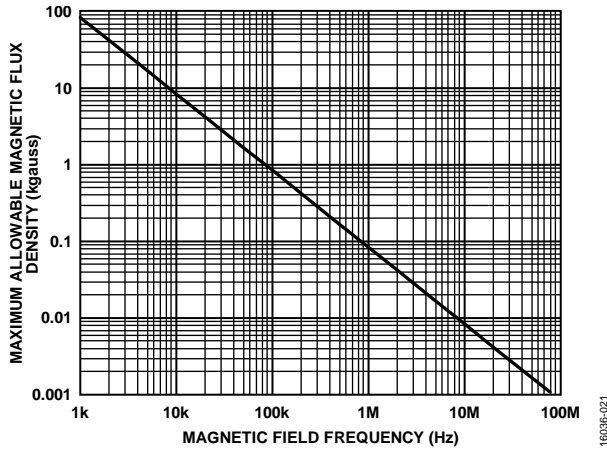

Figure 28. Maximum Allowable External Magnetic Flux Density

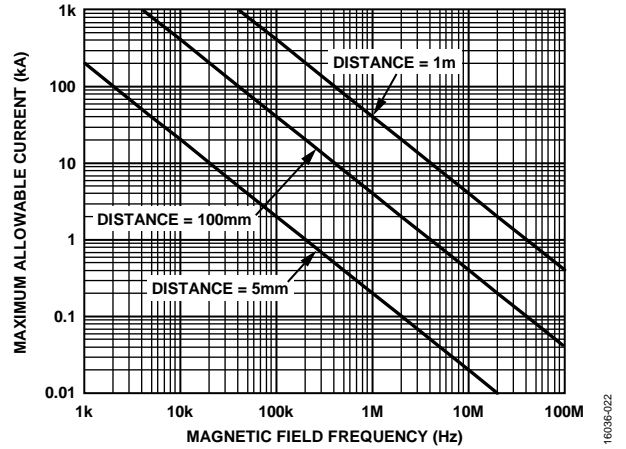

Figure 29. Maximum Allowable Current for Various Current to ADuM4138 Spacing

**TYPICAL APPLICATION CIRCUIT**

See Figure 30 for an example application of the IGBT drive.

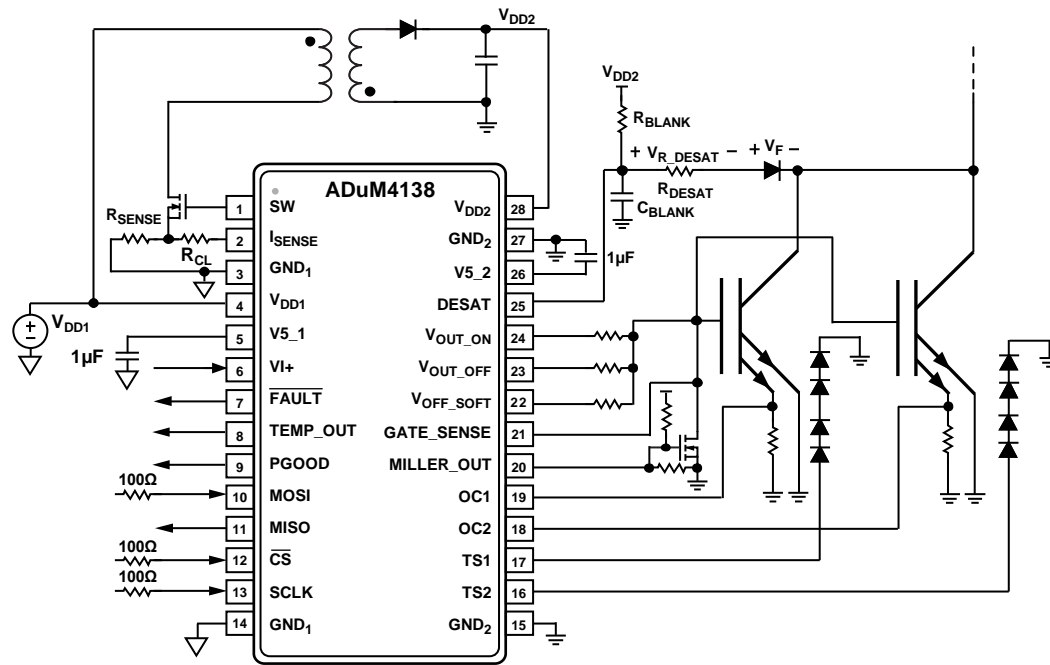

Figure 30. IGBT Drive Example Application, Snubber Can Be Added to Flyback

OUTLINE DIMENSIONS

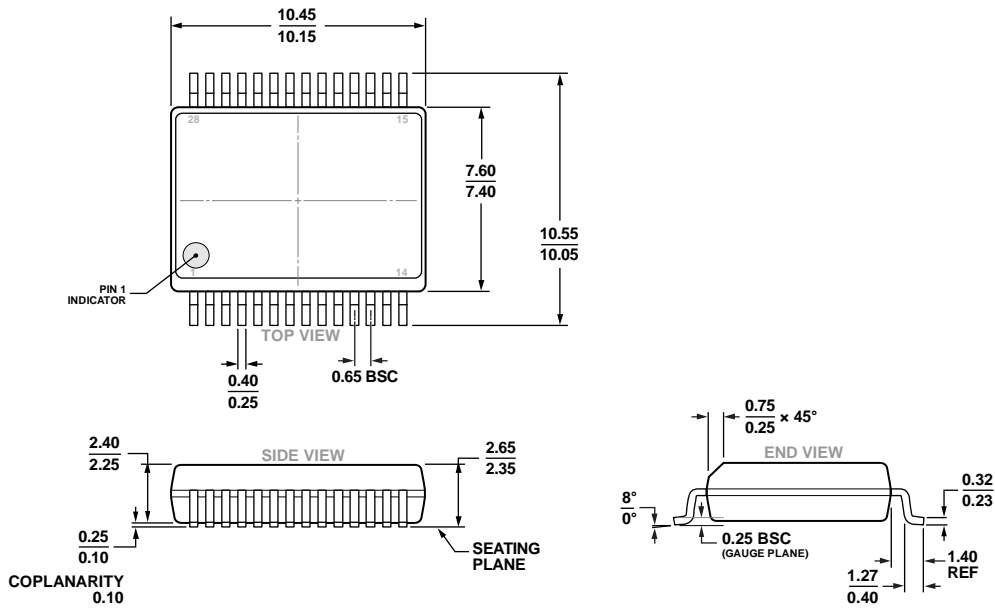

Figure 31. 28-Lead Standard Small Outline, Wide Body with Finer Pitch [SOIC\_W\_FP] (RN-28-1)  
 Dimensions shown in millimeters

ORDERING GUIDE

Model <sup>1, 2</sup>	Temperature Range	Package Description	Package Option
ADuM4138WBRNZ	-40°C to +150°C	28-Lead Standard Small Outline, Wide Body with Finer Pitch [SOIC_W_FP]	RN-28-1
ADuM4138WBRNZ-RL	-40°C to +150°C	28-Lead Standard Small Outline, Wide Body, with Finer Pitch [SOIC_W_FP]	RN-28-1
EVAL-ADuM4138EBZ		Evaluation Board	

<sup>1</sup> Z = RoHS Compliant Part.  
<sup>2</sup> W = Qualified for Automotive Applications.

AUTOMOTIVE PRODUCTS

The ADuM4138W models are available with controlled manufacturing to support the quality and reliability requirements of automotive applications. Note that these automotive models may have specifications that differ from the commercial models; therefore, designers should review the Specifications section of this data sheet carefully. Only the automotive grade products shown are available for use in automotive applications. Contact your local Analog Devices account representative for specific product ordering information and to obtain the specific Automotive Reliability reports for these models.



# Mouser Electronics

Authorized Distributor

Click to View Pricing, Inventory, Delivery & Lifecycle Information:

[Analog Devices Inc.:](#)

[ADUM4138WBRNZ](#) [ADUM4138WBRNZ-RL](#) [EVAL-ADUM4138EBZ](#)