

# UG515: EFM32PG23 Pro Kit User's Guide

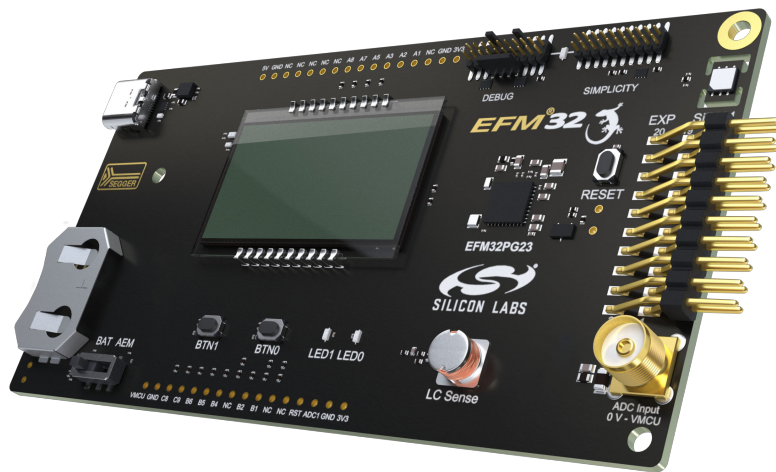

The PG23 Pro Kit is an excellent starting point to become familiar with the EFM32PG23™ Gecko Microcontroller.

The pro kit contains sensors and peripherals demonstrating some of the EFM32PG23's many capabilities. The kit provides all necessary tools for developing an EFM32PG23 Gecko application.



## TARGET DEVICE

- EFM32PG23 Gecko Microcontroller (EFM32PG23B310F512IM48-B)
- CPU: 32-bit ARM® Cortex-M33
- Memory: 512 kB flash and 64 kB RAM

## KIT FEATURES

- USB connectivity
- Advanced Energy Monitor (AEM)
- SEGGER J-Link on-board debugger
- Debug multiplexer supporting external hardware as well as on-board MCU
- 4x10 segment LCD
- User LEDs and push buttons
- Silicon Labs' Si7021 Relative Humidity and Temperature Sensor
- SMA connector for IADC demonstration
- Inductive LC sensor
- 20-pin 2.54 mm header for expansion boards
- Breakout pads for direct access to I/O pins
- Power sources include USB and CR2032 coin cell battery.

## SOFTWARE SUPPORT

- Simplicity Studio™
- IAR Embedded Workbench
- Keil MDK

# Table of Contents

<b>1. Introduction . . . . .</b>	<b>4</b>
1.1 Description . . . . .	4
1.2 Features . . . . .	4
1.3 Getting Started . . . . .	4
<b>2. Kit Block Diagram . . . . .</b>	<b>5</b>
<b>3. Kit Hardware Layout . . . . .</b>	<b>6</b>
<b>4. Connectors . . . . .</b>	<b>7</b>
4.1 Breakout Pads . . . . .	7
4.2 EXP Header . . . . .	9
4.3 Debug Connector (DBG) . . . . .	11
4.4 Simplicity Connector . . . . .	12
<b>5. Power Supply and Reset . . . . .</b>	<b>13</b>
5.1 MCU Power Selection . . . . .	13
5.2 Board Controller Power . . . . .	13
5.3 EFM32PG23 Reset . . . . .	14
<b>6. Peripherals . . . . .</b>	<b>15</b>
6.1 Push Buttons and LEDs . . . . .	15
6.2 LCD . . . . .	15
6.3 Si7021 Relative Humidity and Temperature Sensor . . . . .	16
6.4 LC Sensor . . . . .	17
6.5 IADC SMA Connector . . . . .	17
6.6 Virtual COM Port . . . . .	18
<b>7. Advanced Energy Monitor . . . . .</b>	<b>19</b>
7.1 Usage . . . . .	19
7.2 Theory of Operation . . . . .	19
7.3 Accuracy and Performance . . . . .	19
<b>8. On-Board Debugger . . . . .</b>	<b>20</b>
8.1 Debug Modes . . . . .	21
8.2 Debugging During Battery Operation . . . . .	22
<b>9. Kit Configuration and Upgrades . . . . .</b>	<b>23</b>
9.1 Firmware Upgrades . . . . .	23
<b>10. Schematics, Assembly Drawings, and BOM . . . . .</b>	<b>24</b>
<b>11. Kit Revision History and Errata . . . . .</b>	<b>25</b>
11.1 Revision History . . . . .	25

11.2 Errata . . . . .	.25
<b>12. Document Revision History . . . . .</b>	<b>.26</b>

## 1. Introduction

### 1.1 Description

The PG23 Pro Kit is an ideal starting point for application development on the EFM32PG23 Gecko Microcontrollers. The board features sensors and peripherals, demonstrating some of the many capabilities of the EFM32PG23 Gecko Microcontroller. Additionally, the board is a fully featured debugger and energy monitoring tool that can be used with external applications.

### 1.2 Features

- EFM32PG23 Gecko Microcontroller
  - 512 kB Flash
  - 64 kB RAM
  - QFN48 package
- Advanced Energy Monitoring system for precise current and voltage tracking
- Integrated Segger J-Link USB debugger/emulator with the possibility to debug external Silicon Labs devices
- 20-pin expansion header
- Breakout pads for easy access to I/O pins
- Power sources include USB and CR2032 battery
- 4x10 segment LCD
- 2 push buttons and LEDs connected to EFM32 for user interaction
- Silicon Labs' Si7021 Relative Humidity and Temperature Sensor
- SMA connector for EFM32 IADC demonstration
- External 1.25 V reference for the EFM32 IADC
- LC tank circuit for inductive proximity sensing of metallic objects
- Crystals for LFXO and HFXO: 32.768 kHz and 39.000 MHz

### 1.3 Getting Started

Detailed instructions for how to get started with your new PG23 Pro Kit can be found on the Silicon Labs Web pages:

[silabs.com/development-tools](https://silabs.com/development-tools)

## 2. Kit Block Diagram

An overview of the PG23 Pro Kit is shown in the figure below.

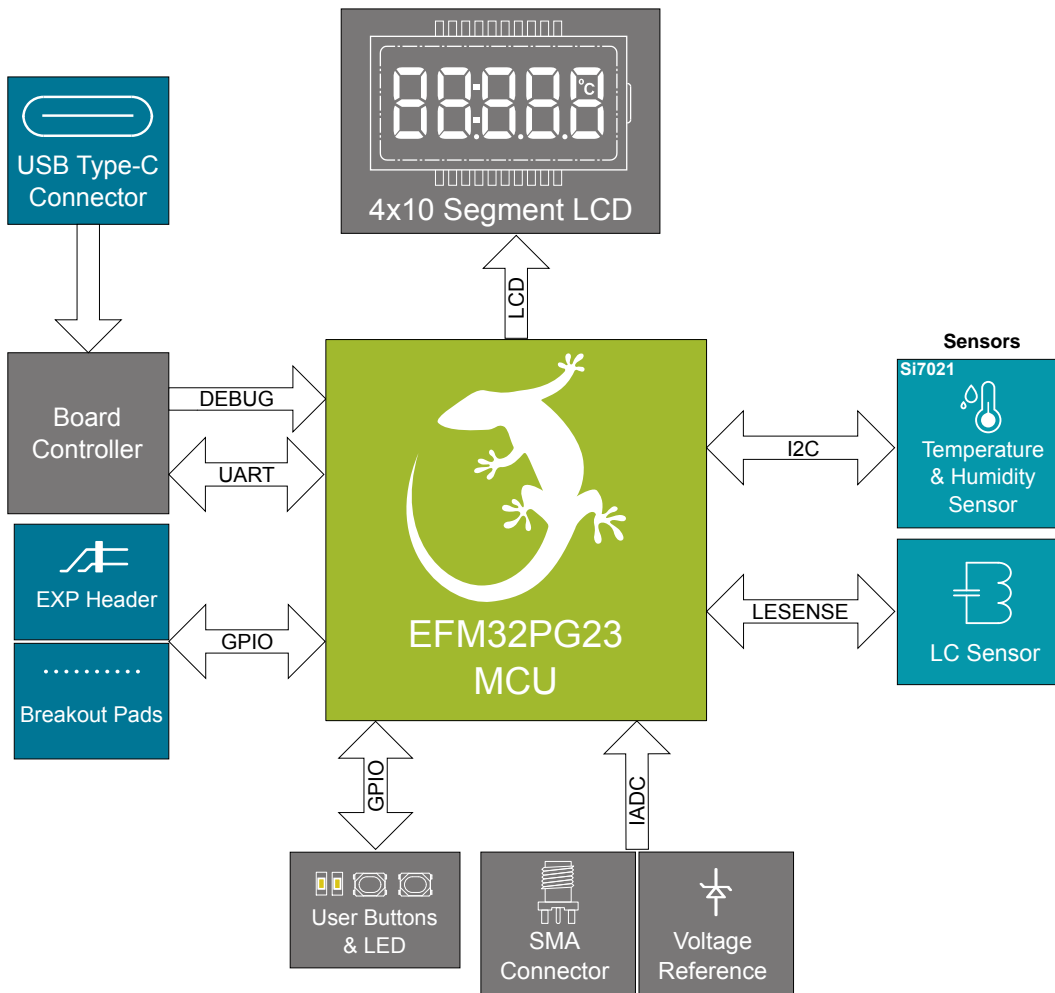

Figure 2.1. Kit Block Diagram

### 3. Kit Hardware Layout

The PG23 Pro Kit layout is shown below.

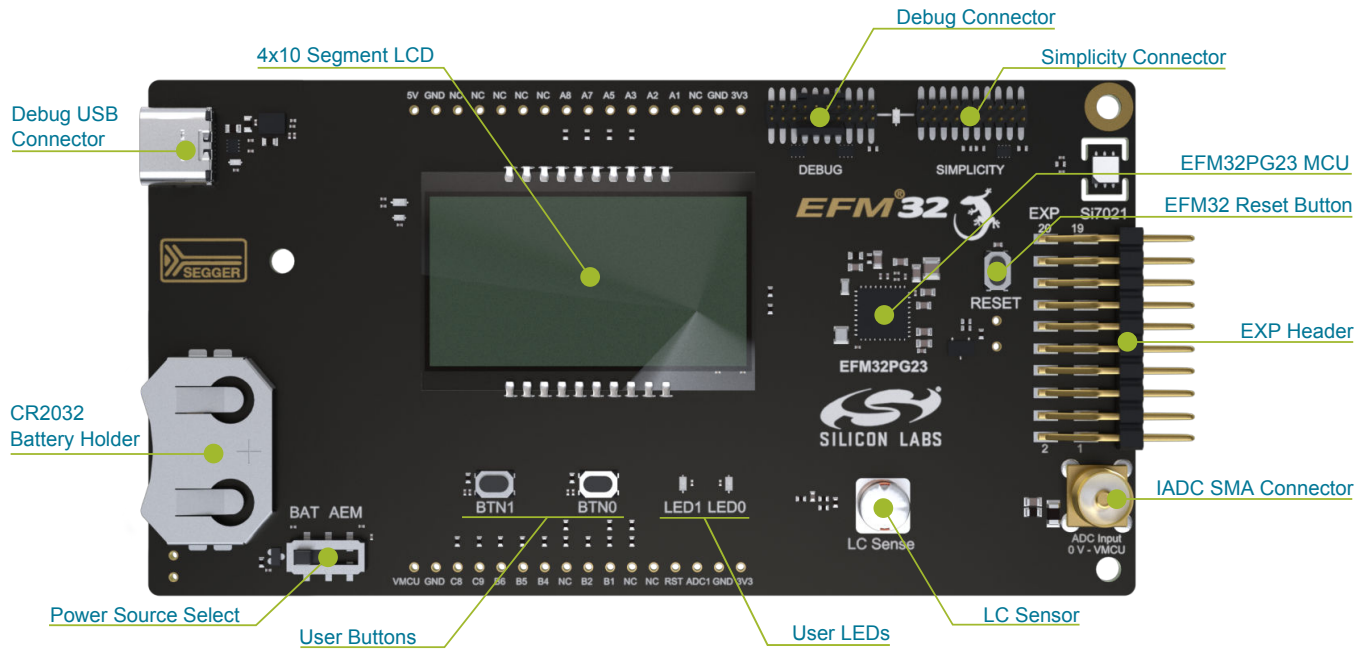

Figure 3.1. PG23 Pro Kit Hardware Layout

## 4. Connectors

### 4.1 Breakout Pads

Most of the EFM32PG23's GPIO pins are available on the pin header rows at the top and bottom edges of the board. These have a standard 2.54 mm pitch, and pin headers can be soldered in if required. In addition to the I/O pins, connections to power rails and ground are also provided. Note that some of the pins are used for kit peripherals or features and may not be available for a custom application without tradeoffs.

The figure below shows the pinout of the breakout pads and the pinout of the EXP header on the right edge of the board. The EXP header is further explained in the next section. The breakout pad connections are also printed in silkscreen next to each pin for easy reference.

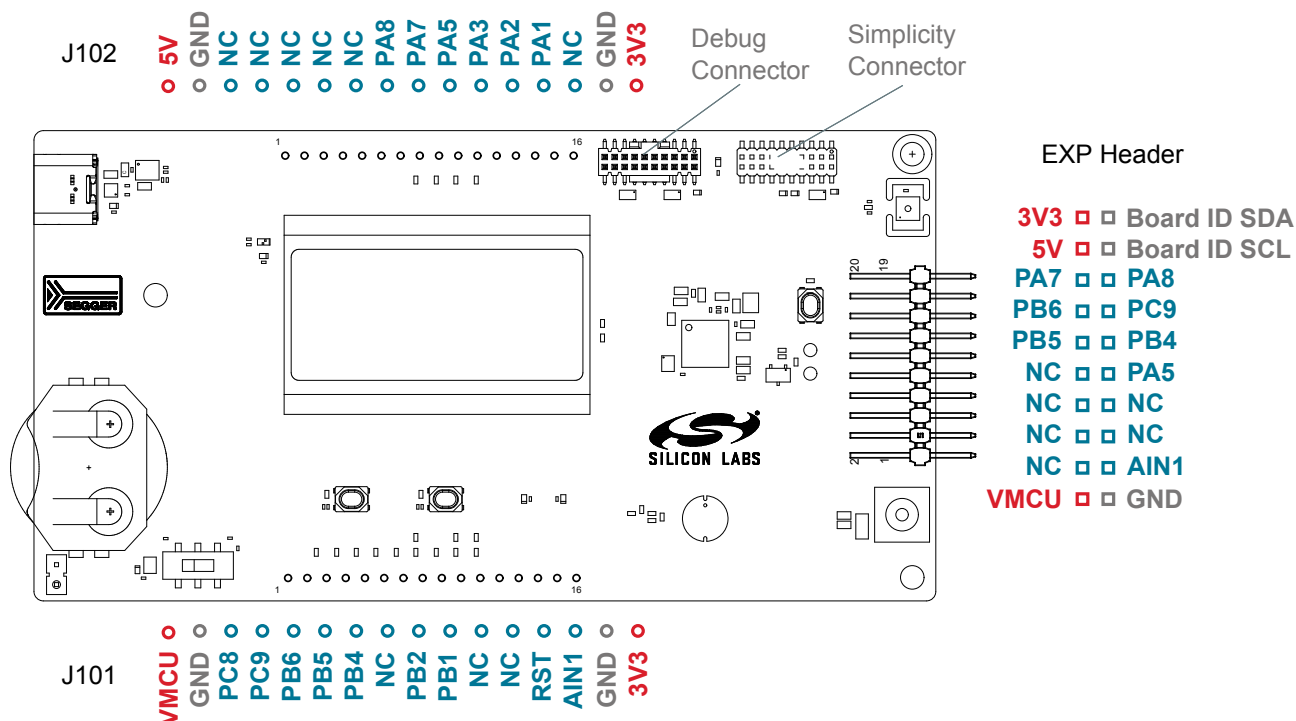

Figure 4.1. Breakout Pads and Expansion Header

The table below shows the pin connections for the breakout pads. It also shows which kit peripherals or features are connected to the different pins.

Table 4.1. Bottom Row (J101) Pinout

Pin	EFM32PG23 I/O Pin	Shared Feature
1	VMCU	EFM32PG23 voltage domain (measured by AEM)
2	GND	Ground
3	PC8	UIF_LED0
4	PC9	UIF_LED1 / EXP13
5	PB6	VCOM_RX / EXP14
6	PB5	VCOM_TX / EXP12
7	PB4	UIF_BUTTON1 / EXP11
8	NC	
9	PB2	ADC_VREF_ENABLE

Pin	EFM32PG23 I/O Pin	Shared Feature
10	PB1	VCOM_ENABLE
11	NC	
12	NC	
13	RST	EFM32PG23 Reset
14	AIN1	
15	GND	Ground
16	3V3	Board controller supply

**Table 4.2. Top Row (J102) Pinout**

Pin	EFM32PG23 I/O Pin	Shared Feature
1	5V	Board USB voltage
2	GND	Ground
3	NC	
4	NC	
5	NC	
6	NC	
7	NC	
8	PA8	SENSOR_I2C_SCL / EXP15
9	PA7	SENSOR_I2C_SDA / EXP16
10	PA5	UIF_BUTTON0 / EXP9
11	PA3	DEBUG_TDO_SWO
12	PA2	DEBUG_TMS_SWDIO
13	PA1	DEBUG_TCK_SWCLK
14	NC	
15	GND	Ground
16	3V3	Board controller supply



## 4.2 EXP Header

On the right side of the board, an angled 20-pin EXP header is provided to allow connection of peripherals or plugin boards. The connector contains a number of I/O pins that can be used with most of the EFM32PG23 Gecko's features. Additionally, the VMCU, 3V3, and 5V power rails are also exposed.

The connector follows a standard which ensures that commonly used peripherals such as a SPI, a UART, and I<sup>2</sup>C bus are available on fixed locations on the connector. The rest of the pins are used for general purpose I/O. This allows the definition of expansion boards that can plug into a number of different Silicon Labs kits.

The figure below shows the pin assignment of the EXP header for the PG23 Pro Kit. Because of limitations in the number of available GPIO pins, some of the EXP header pins are shared with kit features.

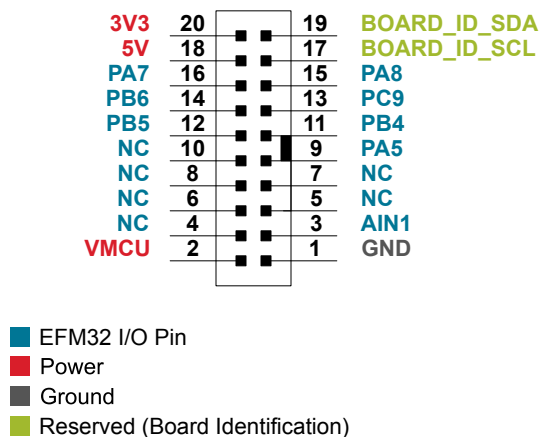

Figure 4.2. EXP Header

Table 4.3. EXP Header Pinout

Pin	Connection	EXP Header Function	Shared Feature
20	3V3	Board controller supply	
18	5V	Board controller USB voltage	
16	PA7	I2C_SDA	SENSOR_I2C_SDA
14	PB6	UART_RX	VCOM_RX
12	PB5	UART_TX	VCOM_TX
10	NC		
8	NC		
6	NC		
4	NC		
2	VMCU	EFM32PG23 voltage domain, included in AEM measurements.	
19	BOARD_ID_SDA	Connected to board controller for identification of add-on boards.	
17	BOARD_ID_SCL	Connected to board controller for identification of add-on boards.	
15	PA8	I2C_SCL	SENSOR_I2C_SCL
13	PC9	GPIO	UIF_LED1
11	PB4	GPIO	UIF_BUTTON1
9	PA5	GPIO	UIF_BUTTON0

Pin	Connection	EXP Header Function	Shared Feature
7	NC		
5	NC		
3	AIN1	ADC Input	
1	GND	Ground	

### 4.3 Debug Connector (DBG)

The debug connector serves a dual purpose, based on the debug mode, which can be set up using Simplicity Studio. If the "Debug IN" mode is selected, the connector allows an external debugger to be used with the on-board EFM32PG23. If the "Debug OUT" mode is selected, the connector allows the kit to be used as a debugger towards an external target. If the "Debug MCU" mode (default) is selected, the connector is isolated from the debug interface of both the board controller and the on-board target device.

Because this connector is automatically switched to support the different operating modes, it is only available when the board controller is powered (J-Link USB cable connected). If debug access to the target device is required when the board controller is unpowered, this should be done by connecting directly to the appropriate pins on the breakout header.

The pinout of the connector follows that of the standard ARM Cortex Debug 19-pin connector. The pinout is described in detail below. Note that even though the connector supports JTAG in addition to Serial Wire Debug, it does not necessarily mean that the kit or the on-board target device supports this.

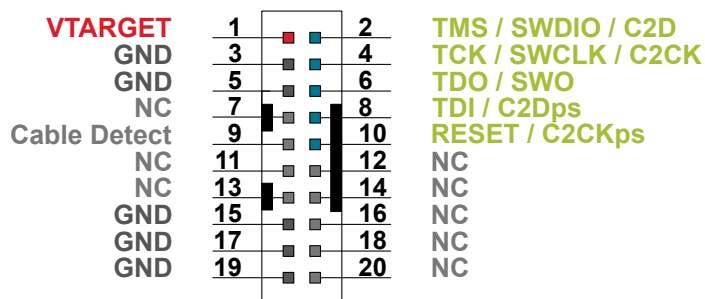

Figure 4.3. Debug Connector

Even though the pinout matches the pinout of an ARM Cortex Debug connector, these are not fully compatible as pin 7 is physically removed from the Cortex Debug connector. Some cables have a small plug that prevents them from being used when this pin is present. If this is the case, remove the plug, or use a standard 2x10 1.27 mm straight cable instead.

Table 4.4. Debug Connector Pin Descriptions

Pin Number(s)	Function	Note
1	VTARGET	Target reference voltage. Used for shifting logical signal levels between target and debugger.
2	TMS / SDWIO / C2D	JTAG test mode select, Serial Wire data or C2 data
4	TCK / SWCLK / C2CK	JTAG test clock, Serial Wire clock or C2 clock
6	TDO/SWO	JTAG test data out or Serial Wire output
8	TDI / C2Dps	JTAG test data in, or C2D "pin sharing" function
10	RESET / C2CKps	Target device reset, or C2CK "pin sharing" function
12	NC	TRACECLK
14	NC	TRACED0
16	NC	TRACED1
18	NC	TRACED2
20	NC	TRACED3
9	Cable detect	Connect to ground
11, 13	NC	Not connected
3, 5, 15, 17, 19	GND	

## 4.4 Simplicity Connector

The Simplicity Connector featured on the pro kit enables advanced debugging features such as the AEM and the Virtual COM port to be used towards an external target. The pinout is illustrated in the figure below.

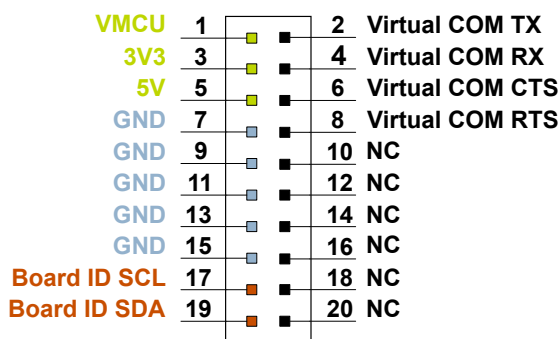

Figure 4.4. Simplicity Connector

The signal names in the figure and the pin description table are referenced from the board controller. This means that VCOM\_TX should be connected to the RX pin on the external target, VCOM\_RX to the target's TX pin, VCOM\_CTS to the target's RTS pin, and VCOM\_RTS to the target's CTS pin.

**Note:** Current drawn from the VMCU voltage pin is included in the AEM measurements, while the 3V3 and 5V voltage pins are not. To monitor the current consumption of an external target with the AEM, put the on-board MCU in its lowest energy mode to minimize its impact on the measurements.

Table 4.5. Simplicity Connector Pin Descriptions

Pin Number(s)	Function	Description
1	VMCU	3.3 V power rail, monitored by the AEM
3	3V3	3.3 V power rail
5	5V	5 V power rail
2	VCOM_TX	Virtual COM TX
4	VCOM_RX	Virtual COM RX
6	VCOM_CTS	Virtual COM CTS
8	VCOM_RTS	Virtual COM RTS
17	BOARD_ID_SCL	Board ID SCL
19	BOARD_ID_SDA	Board ID SDA
10, 12, 14, 16, 18, 20	NC	Not connected
7, 9, 11, 13, 15	GND	Ground

## 5. Power Supply and Reset

### 5.1 MCU Power Selection

The EFM32PG23 on the pro kit can be powered by one of these sources:

- The debug USB cable
- 3 V coin cell battery

The power source for the MCU is selected with the slide switch in the lower left corner of the pro kit. The figure below shows how the different power sources can be selected with the slide switch.

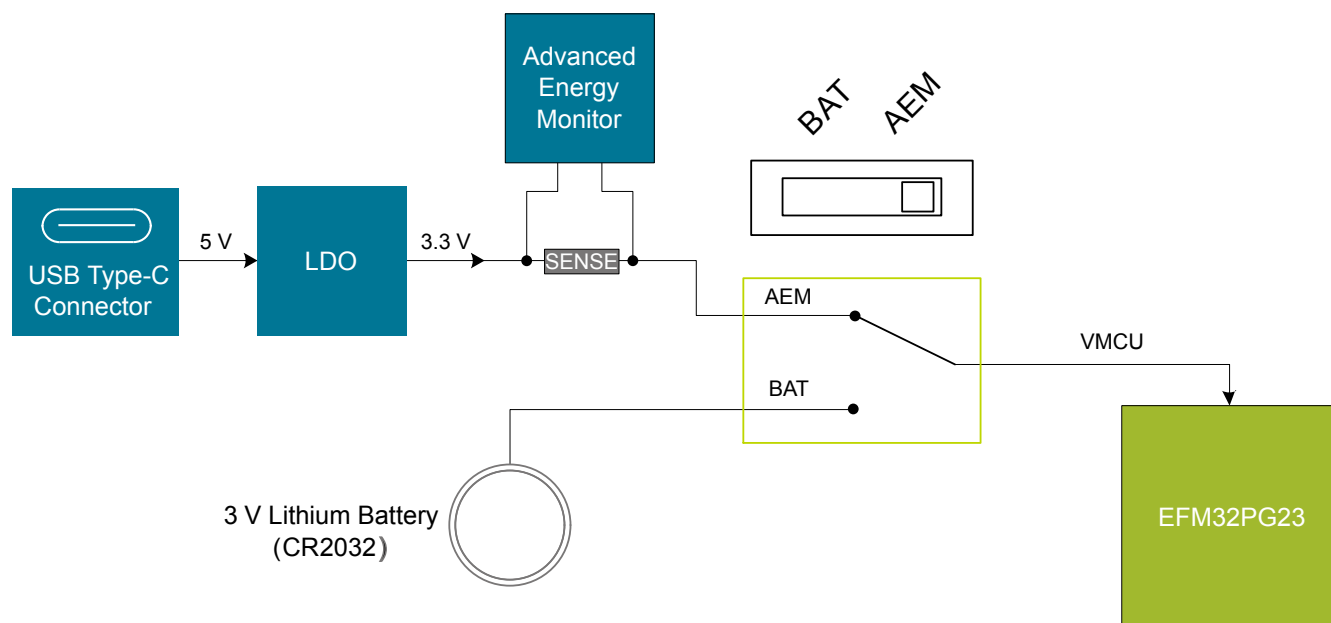

Figure 5.1. Power Switch

With the switch in the **AEM** position, a low noise 3.3 V LDO on the pro kit is used to power the EFM32PG23. This LDO is again powered from the debug USB cable. The Advanced Energy Monitor is now connected in series, allowing accurate high-speed current measurements and energy debugging/profiling.

With the switch in the **BAT** position, a 20 mm coin cell battery in the CR2032 socket can be used to power the device. With the switch in this position, no current measurements are active. This is the recommended switch position when powering the MCU with an external power source.

**Note:** The Advanced Energy Monitor can only measure the current consumption of the EFM32PG23 when the power selection switch is in the **AEM** position.

### 5.2 Board Controller Power

The board controller is responsible for important features, such as the debugger and the AEM, and is powered exclusively through the USB port in the top left corner of the board. This part of the kit resides on a separate power domain, so a different power source can be selected for the target device while retaining debugging functionality. This power domain is also isolated to prevent current leakage from the target power domain when power to the board controller is removed.

The board controller power domain is not influenced by the position of the power switch.

The kit has been carefully designed to keep the board controller and the target power domains isolated from each other as one of them powers down. This ensures that the target EFM32PG23 device will continue to operate in the **BAT** mode.

### 5.3 EFM32PG23 Reset

The EFM32PG23 MCU can be reset by a few different sources:

- A user pressing the RESET button
- The on-board debugger pulling the #RESET pin low
- An external debugger pulling the #RESET pin low

In addition to the reset sources mentioned above, a reset to the EFM32PG23 will also be issued during board controller boot-up. This means that removing power to the board controller (unplugging the J-Link USB cable) will not generate a reset, but plugging the cable back in will, as the board controller boots up.

## 6. Peripherals

The pro kit has a set of peripherals that showcase some of the EFM32PG23 features.

Note that most EFM32PG23 I/O routed to peripherals are also routed to the breakout pads or the EXP header, which must be taken into consideration when using these.

### 6.1 Push Buttons and LEDs

The kit has two user push buttons marked BTN0 and BTN1. They are connected directly to the EFM32PG23 and are debounced by RC filters with a time constant of 1 ms. The buttons are connected to pins PA5 and PB4.

The kit also features two yellow LEDs marked LED0 and LED1 that are controlled by GPIO pins on the EFM32PG23. The LEDs are connected to pins PC8 and PC9 in an active-high configuration.

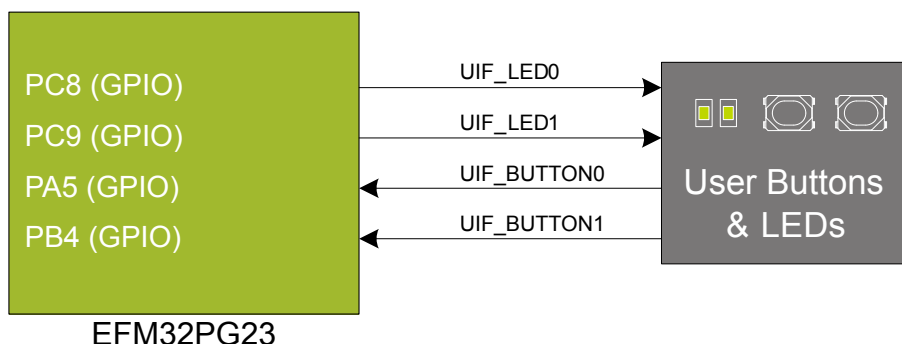

Figure 6.1. Buttons and LEDs

### 6.2 LCD

A 20-pin segment LCD is connected to the EFM32's LCD peripheral. The LCD has 4 common lines and 10 segment lines, giving a total of 40 segments in quadruplex mode. These lines are not shared on the breakout pads. Refer to the kit schematic for information on signals to segments mapping.

A capacitor connected to the EFM32 LCD peripheral's charge pump pin is also available on the kit.

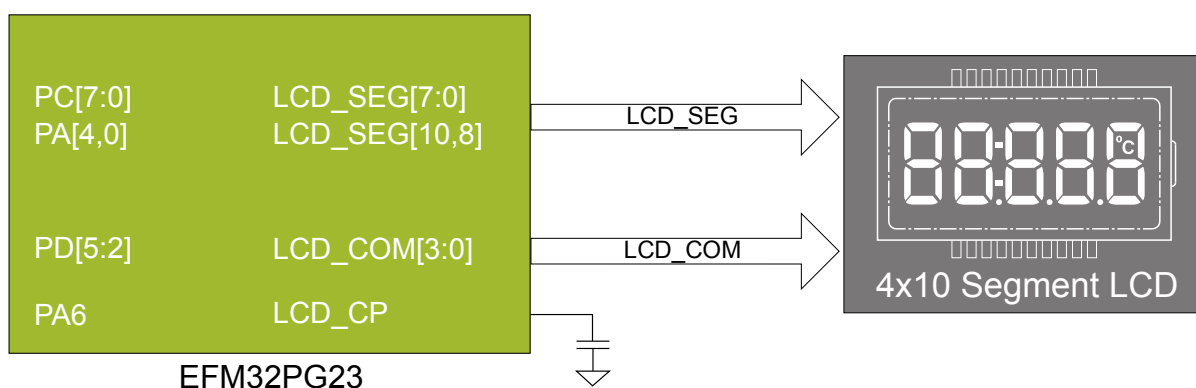

Figure 6.2. Segment LCD

### 6.3 Si7021 Relative Humidity and Temperature Sensor

The Si7021 I<sup>2</sup>C relative humidity and temperature sensor is a monolithic CMOS IC integrating humidity and temperature sensor elements, an analog-to-digital converter, signal processing, calibration data, and an I<sup>2</sup>C Interface. The patented use of industry-standard, low-K polymeric dielectrics for sensing humidity enables the construction of low-power, monolithic CMOS Sensor ICs with low drift and hysteresis, and excellent long term stability.

The humidity and temperature sensors are factory-calibrated and the calibration data is stored in the on-chip non-volatile memory. This ensures that the sensors are fully interchangeable with no recalibration or software changes required.

The Si7021 is available in a 3x3 mm DFN package and is reflow solderable. It can be used as a hardware and software-compatible drop-in upgrade for existing RH/temperature sensors in 3x3 mm DFN-6 packages, featuring precision sensing over a wider range and lower power consumption. The optional factory-installed cover offers a low profile, convenient means of protecting the sensor during assembly (e.g., reflow soldering) and throughout the life of the product, excluding liquids (hydrophobic/oleophobic) and particulates.

The Si7021 offers an accurate, low-power, factory-calibrated digital solution ideal for measuring humidity, dew point, and temperature in applications ranging from HVAC/R and asset tracking to industrial and consumer platforms.

The I<sup>2</sup>C bus used for the Si7021 is shared with the EXP header. The sensor is powered by VMCU, which means the sensor's current consumption is included in the AEM measurements.

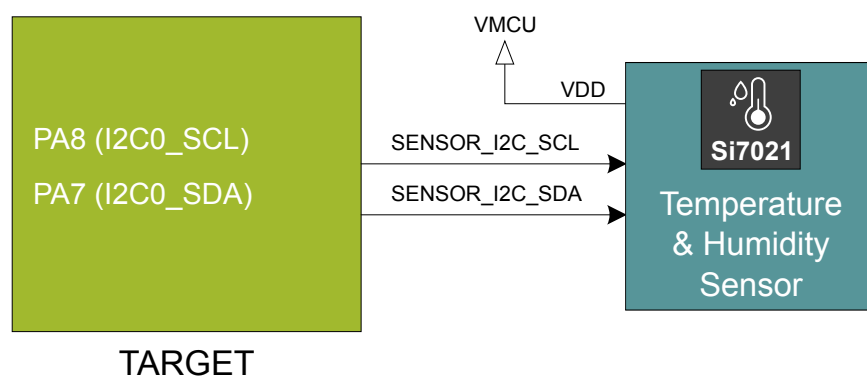

Figure 6.3. Si7021 Relative Humidity and Temperature Sensor

Refer to the Silicon Labs web pages for more information: <http://www.silabs.com/humidity-sensors>.



## 6.4 LC Sensor

An inductive-capacitive sensor for demonstrating the Low Energy Sensor Interface (LESENSE) is located on the bottom right of the board. The LESENSE peripheral uses the voltage digital-to-analog converter (VDAC) to set up an oscillating current through the inductor and then uses the analog comparator (ACMP) to measure the oscillation decay time. The oscillation decay time will be affected by the presence of metal objects within a few millimeters of the inductor.

The LC sensor can be used for implementing a sensor that wakes up the EFM32PG23 from sleep when a metal object comes close to the inductor, which again can be used as a utility meter pulse counter, door alarm switch, position indicator or other applications where one wants to sense the presence of a metal object.

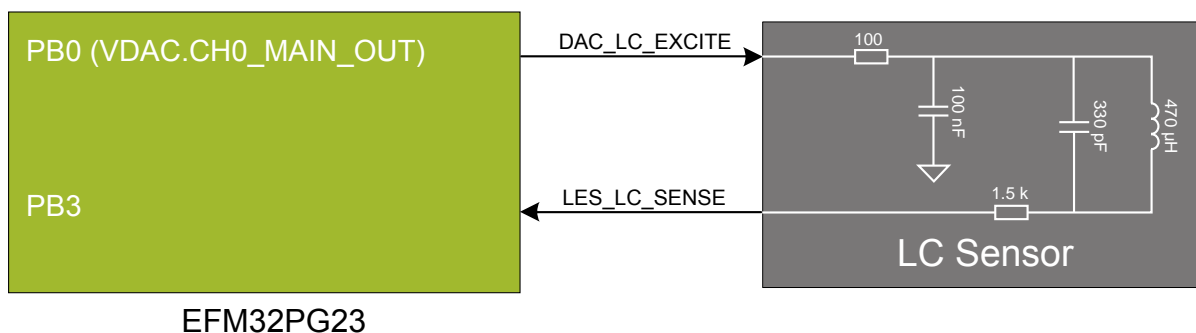

Figure 6.4. LC Metal Sensor

For more information about the LC sensor usage and operation, refer to the application note, "[AN0029: Low Energy Sensor Interface -- Inductive Sense](#)", which is available in Simplicity Studio or in the document library on the Silicon Labs website.

## 6.5 IADC SMA Connector

The kit features an SMA connector which is connected to the EFM32PG23's IADC through one of the dedicated IADC input pins (AIN0) in a single-ended configuration. The dedicated ADC inputs facilitate optimal connections between external signals and the IADC.

The input circuitry between the SMA connector and the ADC pin has been designed to be a good compromise between optimal settling performance at various sampling speeds, and protection of the EFM32 in case of an overvoltage situation. If using the IADC in High Accuracy mode with ADC\_CLK configured to be higher than 1 MHz, it is beneficial to replace the 549  $\Omega$  resistor with 0  $\Omega$ . This comes at the cost of reduced overvoltage protection. See the device reference manual for more information about the IADC.

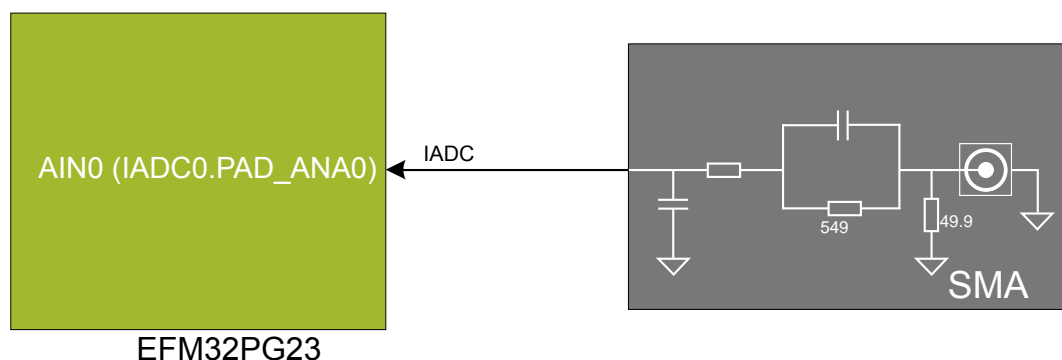
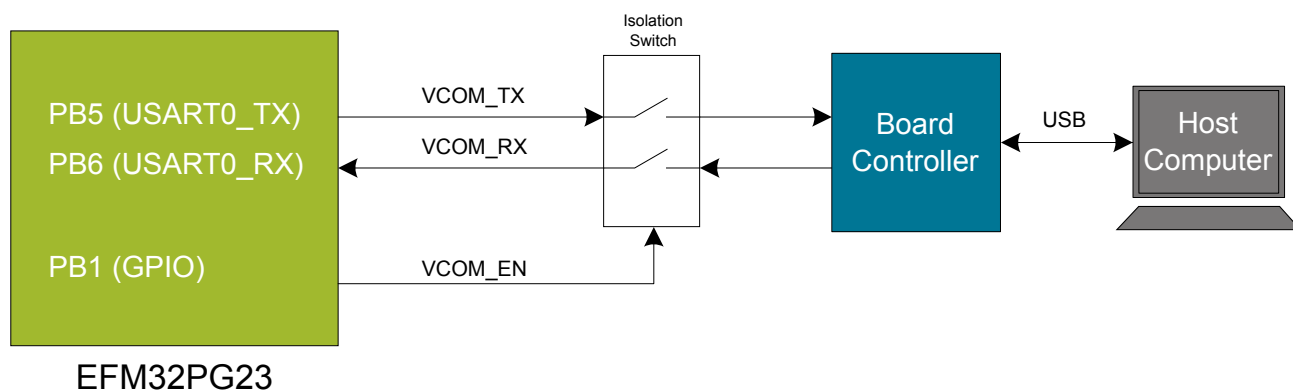

Figure 6.5. SMA Connector

Note that there is a 49.9  $\Omega$  resistor to ground on the SMA connector input which, depending on the output impedance of the source, influences the measurements. The 49.9  $\Omega$  resistor has been added to increase the performance towards 50  $\Omega$  output impedance sources.

## 6.6 Virtual COM Port

An asynchronous serial connection to the board controller is provided for application data transfer between a host PC and the target EFM32PG23, which eliminates the need for an external serial port adapter.



**Figure 6.6. Virtual COM Port Interface**

The Virtual COM port consists of a physical UART between the target device and the board controller, and a logical function in the board controller that makes the serial port available to the host PC over USB. The UART interface consists of two pins and an enable signal.

**Table 6.1. Virtual COM Port Interface Pins**

Signal	Description
VCOM_TX	Transmit data from the EFM32PG23 to the board controller
VCOM_RX	Receive data from the board controller to the EFM32PG23
VCOM_ENABLE	Enables the VCOM interface, allowing data to pass through to the board controller

**Note:** The VCOM port is only available when the board controller is powered, which requires the J-Link USB cable to be inserted.

## 7. Advanced Energy Monitor

### 7.1 Usage

The Advanced Energy Monitor (AEM) data is collected by the board controller and can be displayed by the Energy Profiler, available through Simplicity Studio. By using the Energy Profiler, current consumption and voltage can be measured and linked to the actual code running on the EFM32PG23 in realtime.

### 7.2 Theory of Operation

To accurately measure current ranging from 0.1  $\mu\text{A}$  to 47 mA (114 dB dynamic range), a current sense amplifier is utilized together with a dual gain stage. The current sense amplifier measures the voltage drop over a small series resistor. The gain stage further amplifies this voltage with two different gain settings to obtain two current ranges. The transition between these two ranges occurs around 250  $\mu\text{A}$ . Digital filtering and averaging is done within the board controller before the samples are exported to the Energy Profiler application.

During kit startup, an automatic calibration of the AEM is performed, which compensates for the offset error in the sense amplifiers.

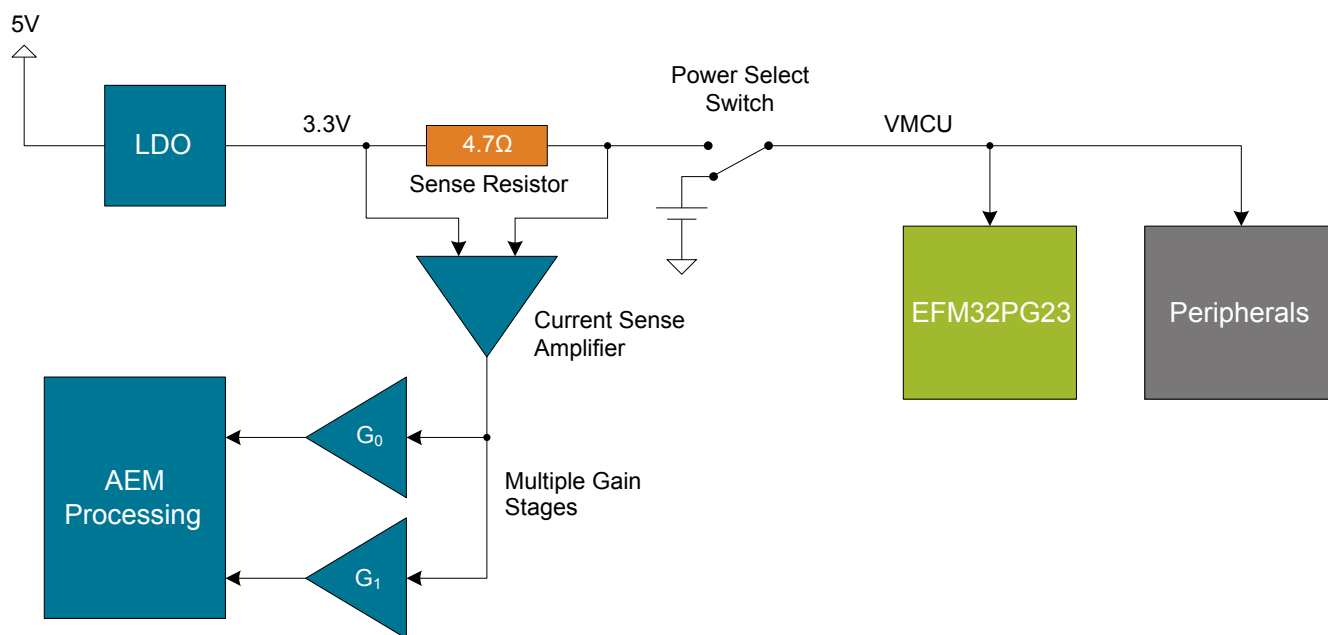

Figure 7.1. Advanced Energy Monitor

### 7.3 Accuracy and Performance

The AEM is capable of measuring currents in the range of 0.1  $\mu\text{A}$  to 47 mA. For currents above 250  $\mu\text{A}$ , the AEM is accurate within 0.1 mA. When measuring currents below 250  $\mu\text{A}$ , the accuracy increases to 1  $\mu\text{A}$ . Although the absolute accuracy is 1  $\mu\text{A}$  in the sub 250  $\mu\text{A}$  range, the AEM is able to detect changes in the current consumption as small as 100 nA. The AEM produces 6250 current samples per second.

## 8. On-Board Debugger

The PG23 Pro Kit contains an integrated debugger, which can be used to download code and debug the EFM32PG23. In addition to programming the EFM32PG23 on the kit, the debugger can also be used to program and debug external Silicon Labs EFM32, EFM8, EZR32, and EFR32 devices.

The debugger supports three different debug interfaces used with Silicon Labs devices:

- Serial Wire Debug, which is used with all EFM32, EFR32, and EZR32 devices
- JTAG, which can be used with EFR32 and some EFM32 devices
- C2 Debug, which is used with EFM8 devices

To ensure accurate debugging, use the appropriate debug interface for your device. The debug connector on the board supports all three of these modes.

## 8.1 Debug Modes

To program external devices, use the debug connector to connect to a target board and set the debug mode to **[Out]**. The same connector can also be used to connect an external debugger to the EFM32PG23 MCU on the kit by setting debug mode to **[In]**.

Selecting the active debug mode is done in Simplicity Studio.

**Debug MCU:** In this mode, the on-board debugger is connected to the EFM32PG23 on the kit.

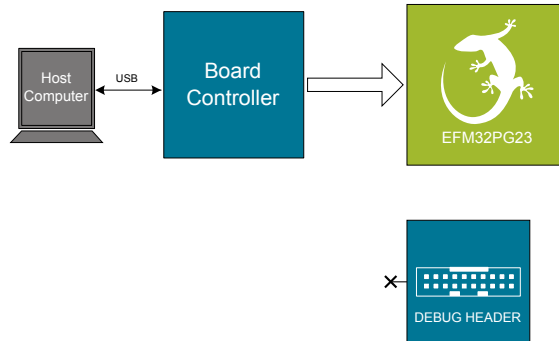

Figure 8.1. Debug MCU

**Debug OUT:** In this mode, the on-board debugger can be used to debug a supported Silicon Labs device mounted on a custom board.

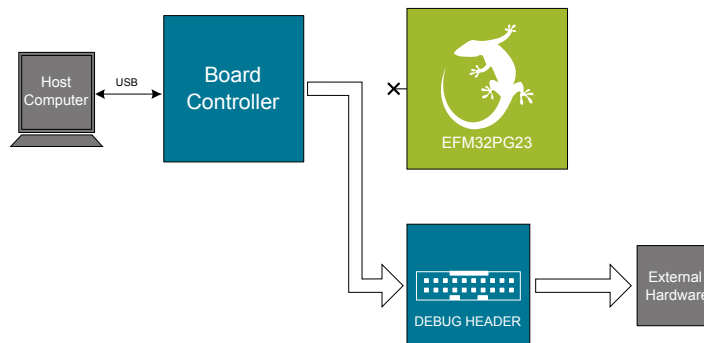

Figure 8.2. Debug OUT

**Debug IN:** In this mode, the on-board debugger is disconnected and an external debugger can be connected to debug the EFM32PG23 on the kit.

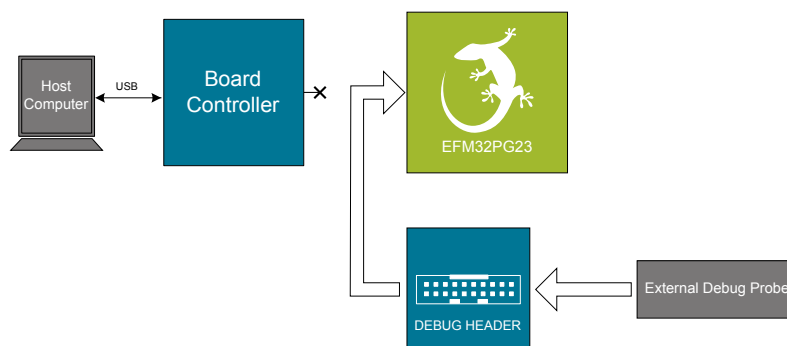

Figure 8.3. Debug IN

**Note:** For "Debug IN" to work, the kit board controller must be powered through the Debug USB connector.

## 8.2 Debugging During Battery Operation

When the EFM32PG23 is battery-powered and the J-Link USB is still connected, the on-board debug functionality is available. If the USB power is disconnected, the Debug IN mode will stop working.

If debug access is required when the target is running off another energy source, such as a battery, and the board controller is powered down, make direct connections to the GPIO used for debugging. This can be done by connecting to the appropriate pins on the break-out pads. Some Silicon Labs kits provide a dedicated pin header for this purpose.

## 9. Kit Configuration and Upgrades

The kit configuration dialog in Simplicity Studio allows you to change the J-Link adapter debug mode, upgrade its firmware, and change other configuration settings. To download Simplicity Studio, go to [silabs.com/simplicity](http://silabs.com/simplicity).

In the main window of the Simplicity Studio's Launcher perspective, the debug mode and firmware version of the selected J-Link adapter are shown. Click the **[Change]** link next to any of them to open the kit configuration dialog.

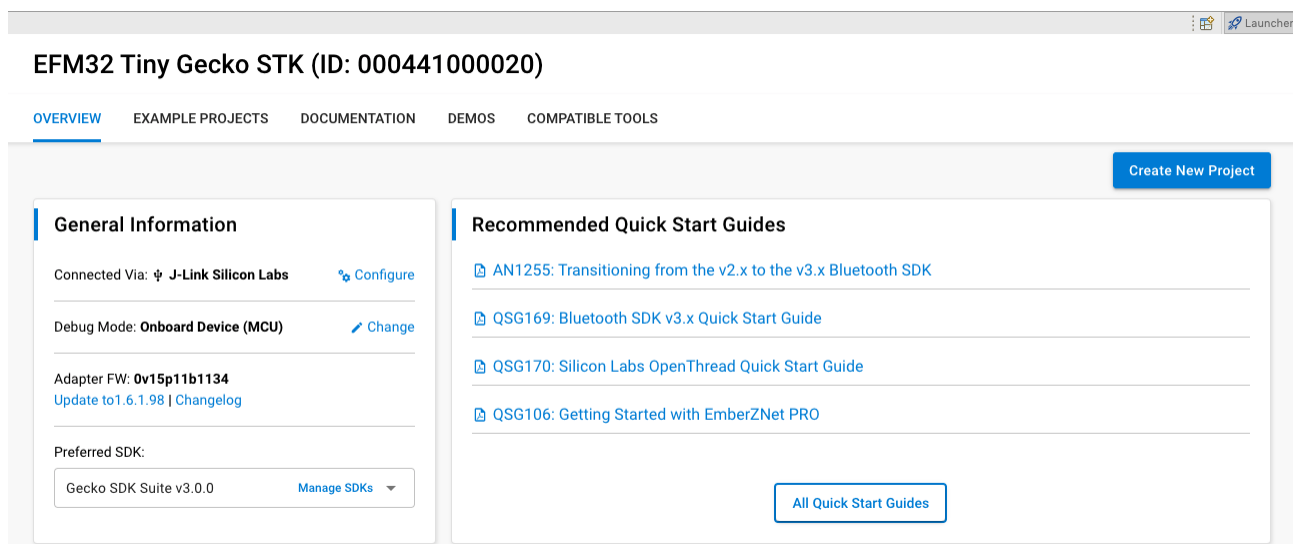

Figure 9.1. Simplicity Studio Kit Information

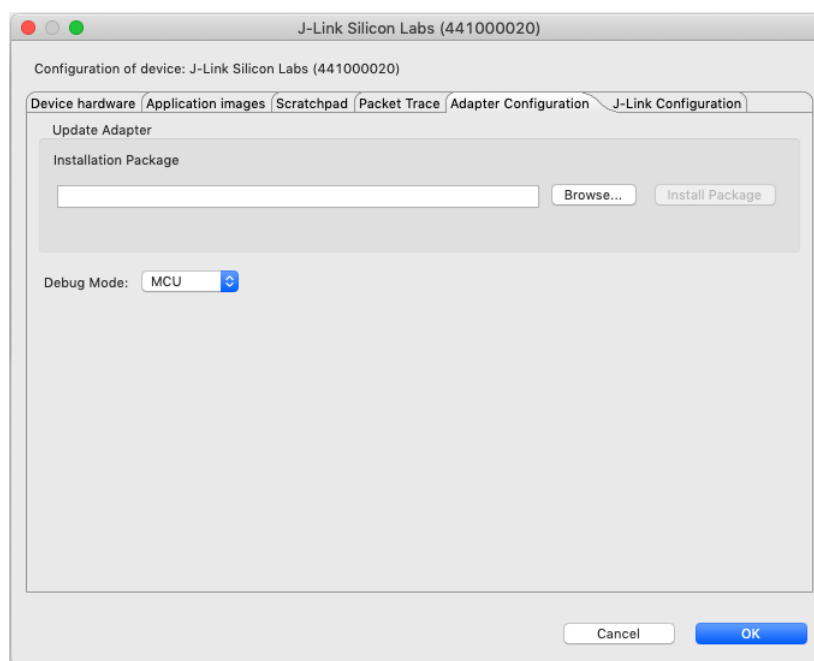

Figure 9.2. Kit Configuration Dialog

### 9.1 Firmware Upgrades

Upgrading the kit firmware is done through Simplicity Studio. Simplicity Studio will automatically check for new updates on startup.

You can also use the kit configuration dialog for manual upgrades. Click the **[Browse]** button in the **[Update Adapter]** section to select the correct file ending in `.emz`. Then, click the **[Install Package]** button.

## 10. Schematics, Assembly Drawings, and BOM

Schematics, assembly drawings, and bill of materials (BOM) are available through Simplicity Studio when the kit documentation package has been installed. They are also available from the kit page on the Silicon Labs website: <http://www.silabs.com/>.



## 11. Kit Revision History and Errata

### 11.1 Revision History

The kit revision can be found printed on the box label of the kit, as outlined in the figure below.



Figure 11.1. Revision Information

Table 11.1. Kit Revision History

Kit Revision	Released	Description
A02	11 August 2021	Initial kit revision featuring BRD2504A revision A03.

### 11.2 Errata

There are currently no known issues with this kit.

## 12. Document Revision History

### 1.0

November 2021

- Initial document version

# Simplicity Studio

One-click access to MCU and wireless tools, documentation, software, source code libraries & more. Available for Windows, Mac and Linux!



**IoT Portfolio**  
[www.silabs.com/IoT](http://www.silabs.com/IoT)



**SW/HW**  
[www.silabs.com/simplicity](http://www.silabs.com/simplicity)



**Quality**  
[www.silabs.com/quality](http://www.silabs.com/quality)



**Support & Community**  
[www.silabs.com/community](http://www.silabs.com/community)

## Disclaimer

Silicon Labs intends to provide customers with the latest, accurate, and in-depth documentation of all peripherals and modules available for system and software implementers using or intending to use the Silicon Labs products. Characterization data, available modules and peripherals, memory sizes and memory addresses refer to each specific device, and "Typical" parameters provided can and do vary in different applications. Application examples described herein are for illustrative purposes only. Silicon Labs reserves the right to make changes without further notice to the product information, specifications, and descriptions herein, and does not give warranties as to the accuracy or completeness of the included information. Without prior notification, Silicon Labs may update product firmware during the manufacturing process for security or reliability reasons. Such changes will not alter the specifications or the performance of the product. Silicon Labs shall have no liability for the consequences of use of the information supplied in this document. This document does not imply or expressly grant any license to design or fabricate any integrated circuits. The products are not designed or authorized to be used within any FDA Class III devices, applications for which FDA premarket approval is required or Life Support Systems without the specific written consent of Silicon Labs. A "Life Support System" is any product or system intended to support or sustain life and/or health, which, if it fails, can be reasonably expected to result in significant personal injury or death. Silicon Labs products are not designed or authorized for military applications. Silicon Labs products shall under no circumstances be used in weapons of mass destruction including (but not limited to) nuclear, biological or chemical weapons, or missiles capable of delivering such weapons. Silicon Labs disclaims all express and implied warranties and shall not be responsible or liable for any injuries or damages related to use of a Silicon Labs product in such unauthorized applications.

**Note: This content may contain offensive terminology that is now obsolete. Silicon Labs is replacing these terms with inclusive language wherever possible. For more information, visit [www.silabs.com/about-us/inclusive-lexicon-project](http://www.silabs.com/about-us/inclusive-lexicon-project)**

## Trademark Information

Silicon Laboratories Inc., Silicon Laboratories®, Silicon Labs®, SiLabs® and the Silicon Labs logo®, Bluegiga®, Bluegiga Logo®, Clockbuilder®, CMEMS®, DSPLL®, EFM®, EFM32®, EFR®, Ember®, Energy Micro, Energy Micro logo and combinations thereof, "the world's most energy friendly microcontrollers", Ember®, EZLink®, EZRadio®, EZRadioPRO®, Gecko®, Gecko OS, Gecko OS Studio, ISOModem®, Precision32®, ProSLIC®, Simplicity Studio®, SiPHY®, Telegesis, the Telegesis Logo®, USBXpress®, Zentri, the Zentri logo and Zentri DMS, Z-Wave®, and others are trademarks or registered trademarks of Silicon Labs. ARM, CORTEX, Cortex-M3 and THUMB are trademarks or registered trademarks of ARM Holdings. Keil is a registered trademark of ARM Limited. Wi-Fi is a registered trademark of the Wi-Fi Alliance. All other products or brand names mentioned herein are trademarks of their respective holders.



Silicon Laboratories Inc.  
400 West Cesar Chavez  
Austin, TX 78701  
USA

[www.silabs.com](http://www.silabs.com)