

THIS DOCUMENT IS THE PROPERTY OF KEYSTONE ELECTRONICS CORP. AND SHALL NOT BE REPRODUCED, DISTRIBUTED OR USED AS A BASIS FOR MANUFACTURE WITHOUT PRIOR WRITTEN PERMISSION FROM KEYSTONE ELECTRONICS CORP.

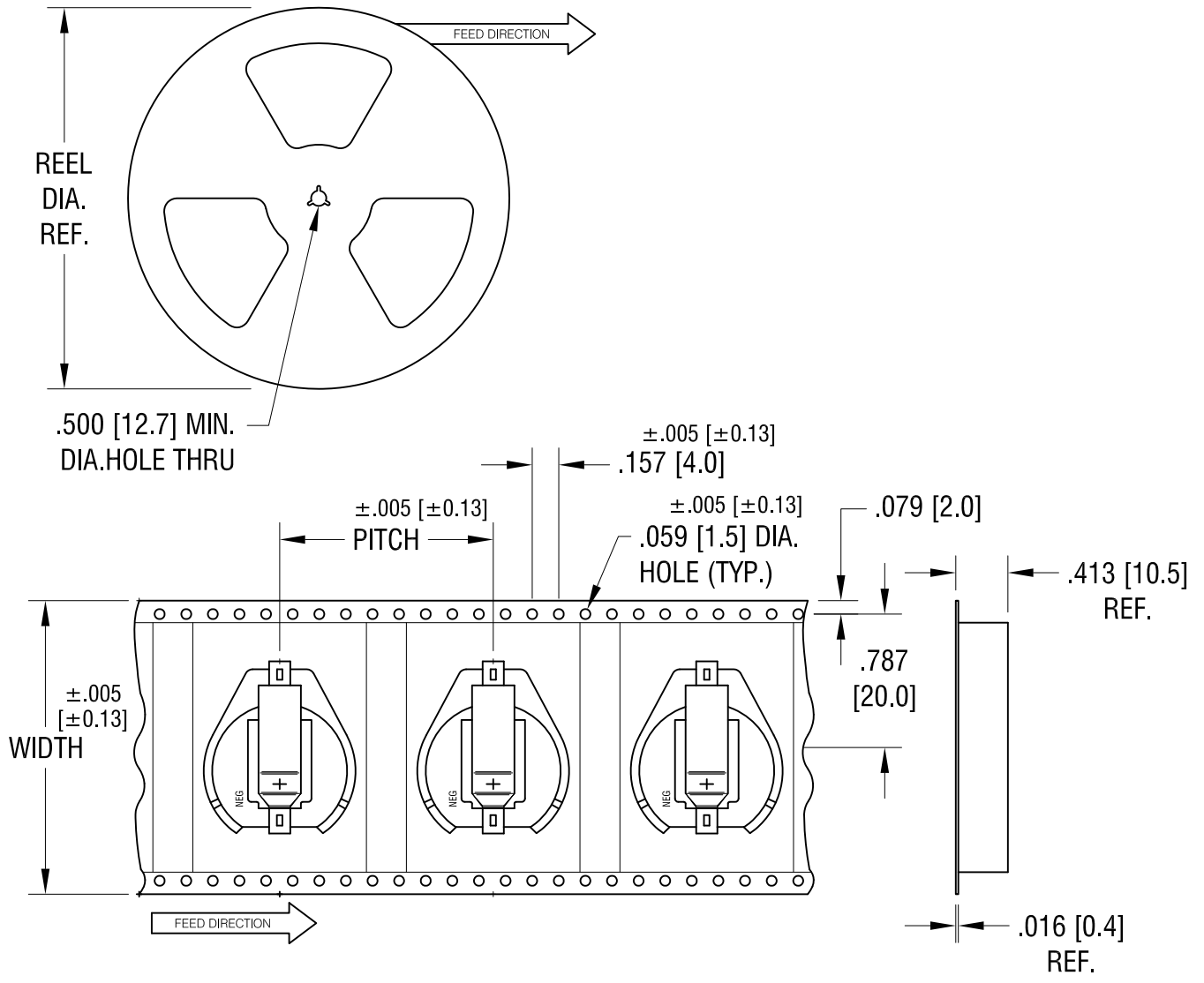

**NOTES:**

**TAPE AND REEL SPECIFICATIONS:**

**1. TAPE:**

MAT'L - ALL CONDUCTIVE POLYSTYRENE CARRIER  
 ANSI/EIA-481 STANDARD  
 1.732 [44.0] WIDE; 1.260 [32.0] PITCH

**2. REEL:**

13.0 [330.2] DIA. 200 PIECES OF  
 PART NO. 1082 PER REEL.

|   |                 |        |               |
|---|-----------------|--------|---------------|
| <b>KEYSTONE ELECTRONICS CORP.</b>                               |                 |        |               |
| www.keyelco.com • ASTORIA, N.Y. 11105-2017 • Tel (718) 956-8900 |                 |        |               |
| PART NAME   |                 |        |               |
| 20mm SM COIN CELL HOLDER ON TAPE                                |                 |        |               |
| MATERIAL  |                 |        |               |
| AS NOTED  |                 |        |               |
| FINISH  |                 | DRN BY | DATE          |
| AS NOTED  |                 | NT     | 3.19.09       |
|   |                 | APP'D  | SCALE         |
|   |                 | LN     | X             |
| TOLERANCES  | INCH [MM]       | CODE   | DWG NO.       |
| DECIMAL   | ± .015 [± 0.38] | C      | <b>1082TR</b> |
| ANGULAR   | ± 1°            |        |               |
| UNLESS OTHERWISE SPECIFIED                                      |                 |        |               |

|      |             |      |  |
|------|-------------|------|--|
| DATE | DESCRIPTION | REV. |  |
|------|-------------|------|--|

**MOUNTING DETAIL**

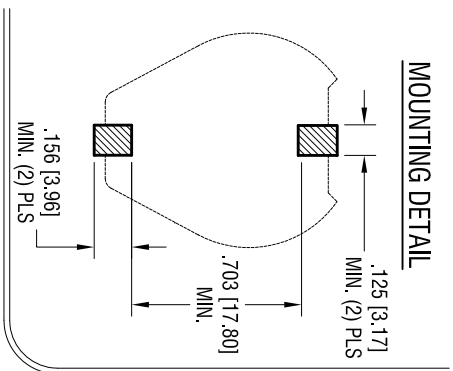

**SECTION A-A**

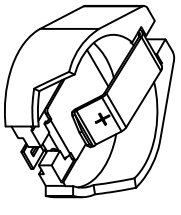
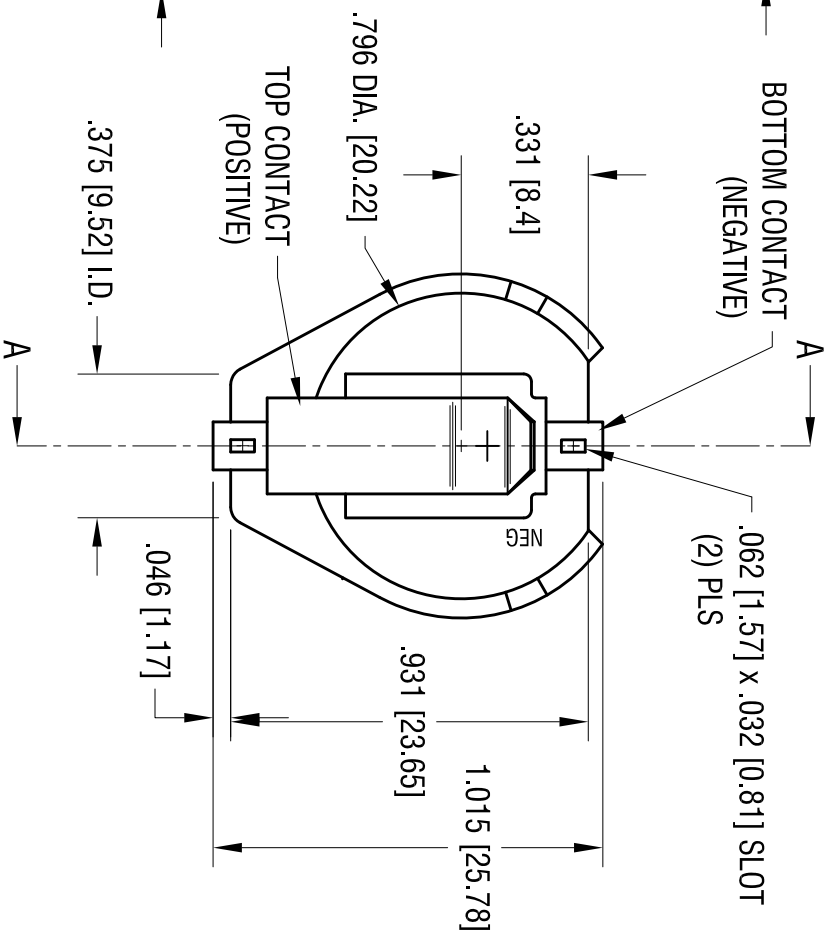
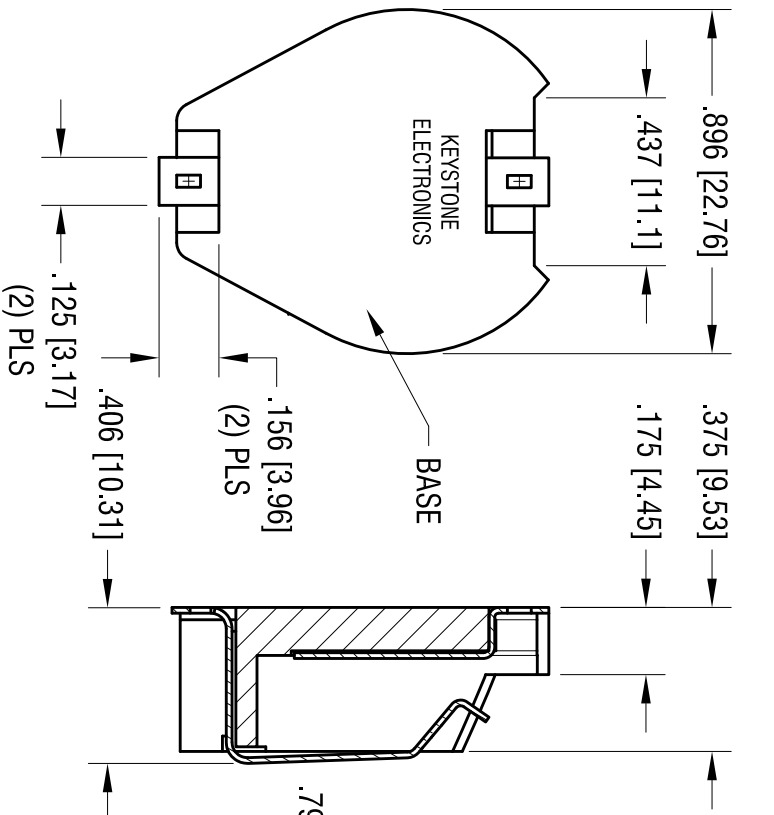

**ACTUAL SIZE**

- NOTES:**
1. BASE:  
MAT'L - HIGH TEMPERATURE NYLON (UL 94V-0)  
COLOR BLACK
  2. CONTACTS (TOP AND BOTTOM):  
MAT'L - .015 [0.38] THK SPRING STEEL  
FINISH: GOLD FLASH PLATE

| DATE    | DESCRIPTION              | REV. |
|---------|--------------------------|------|
| 8.12.11 | CHANGE AS PER ECN 11-104 | A    |

|   |  |                 |  |
|---|--|-----------------|--|
| <b>KEYSTONE ELECTRONICS CORP.</b>                               |  |                 |  |
| www.keystec.com • ASTORIA, N.Y. 11105-2017 • Tel (718) 956-8900 |  |                 |  |
| PART NAME<br>DUAL 20mm BATTERY HOLDER, SMT                      |  |                 |  |
| MATERIAL<br>AS NOTED  |  |                 |  |
| FINISH<br>AS NOTED  |  | DRN BY<br>NT    |  |
| TOLERANCES<br>DECIMAL ± .010 [± 0.25]<br>ANGULAR ± 1°           |  | DATE<br>3.19.09 |  |
| CODE<br>C   |  | DWG NO.<br>1082 |  |

THIS DOCUMENT IS THE PROPERTY OF KEYSTONE ELECTRONICS CORP. AND SHALL NOT BE REPRODUCED, DISTRIBUTED OR USED AS A BASIS FOR MANUFACTURE WITHOUT PRIOR WRITTEN PERMISSION FROM KEYSTONE ELECTRONICS CORP.

# Mouser Electronics

Authorized Distributor

Click to View Pricing, Inventory, Delivery & Lifecycle Information:

[Keystone Electronics:](#)

[1082TR](#)