

# Customer Information Sheet

DRAWING No.: S7051-42R

SHEET 2 OF 2

IF IN DOUBT - ASK

©

NOT TO SCALE

THIRD ANGLE PROJECTION

ALL DIMENSIONS IN mm

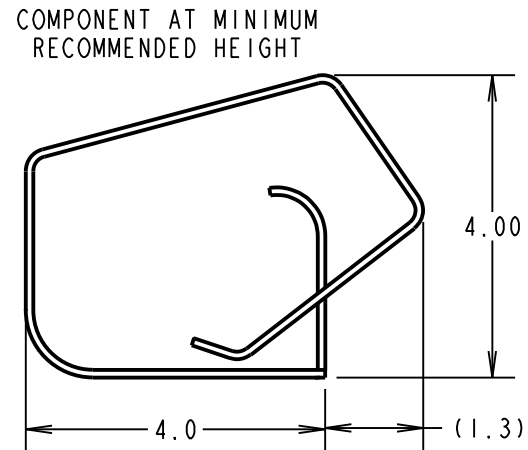
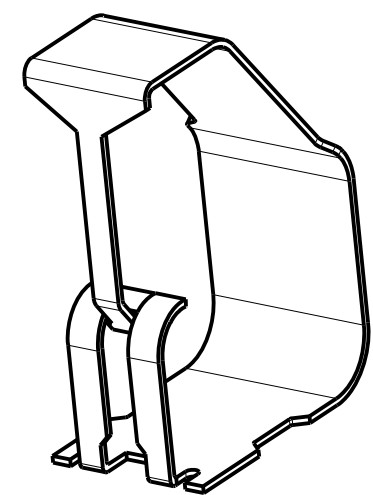
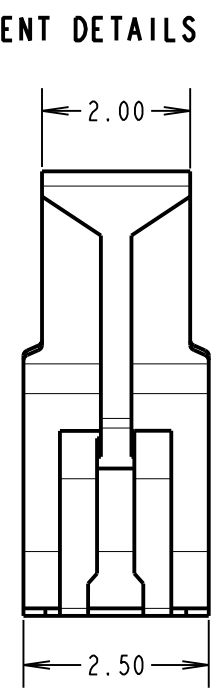
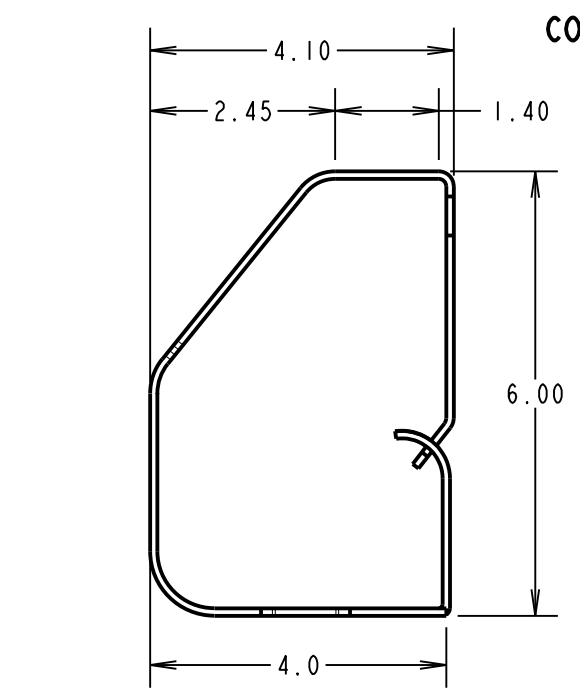
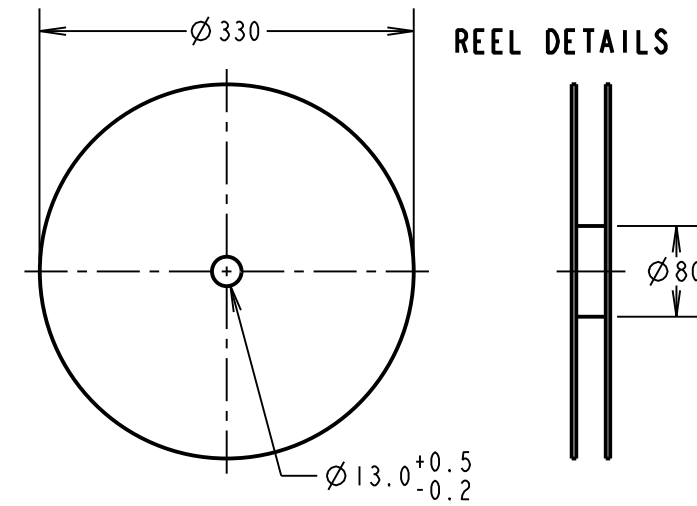
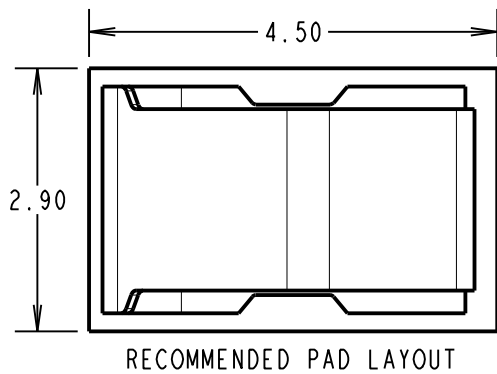
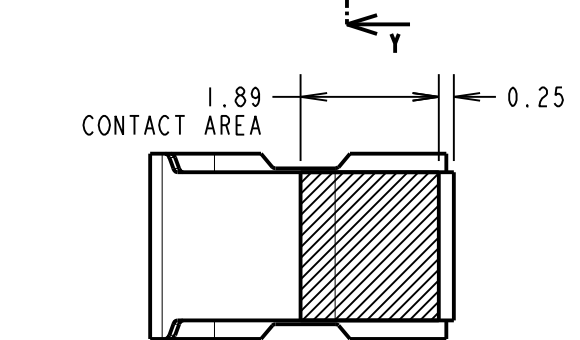
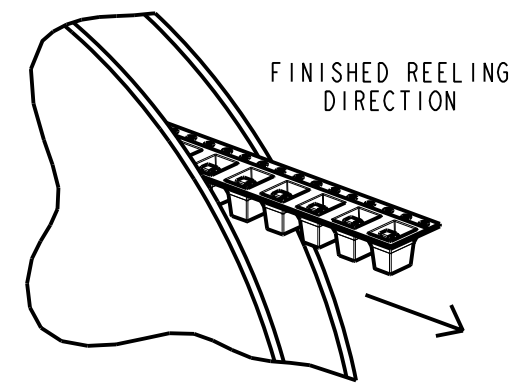
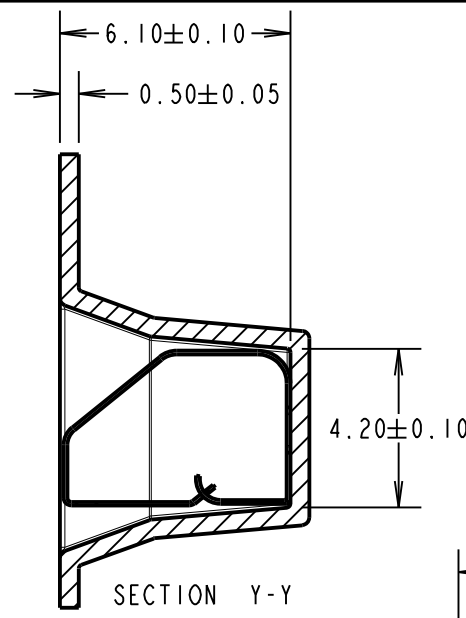
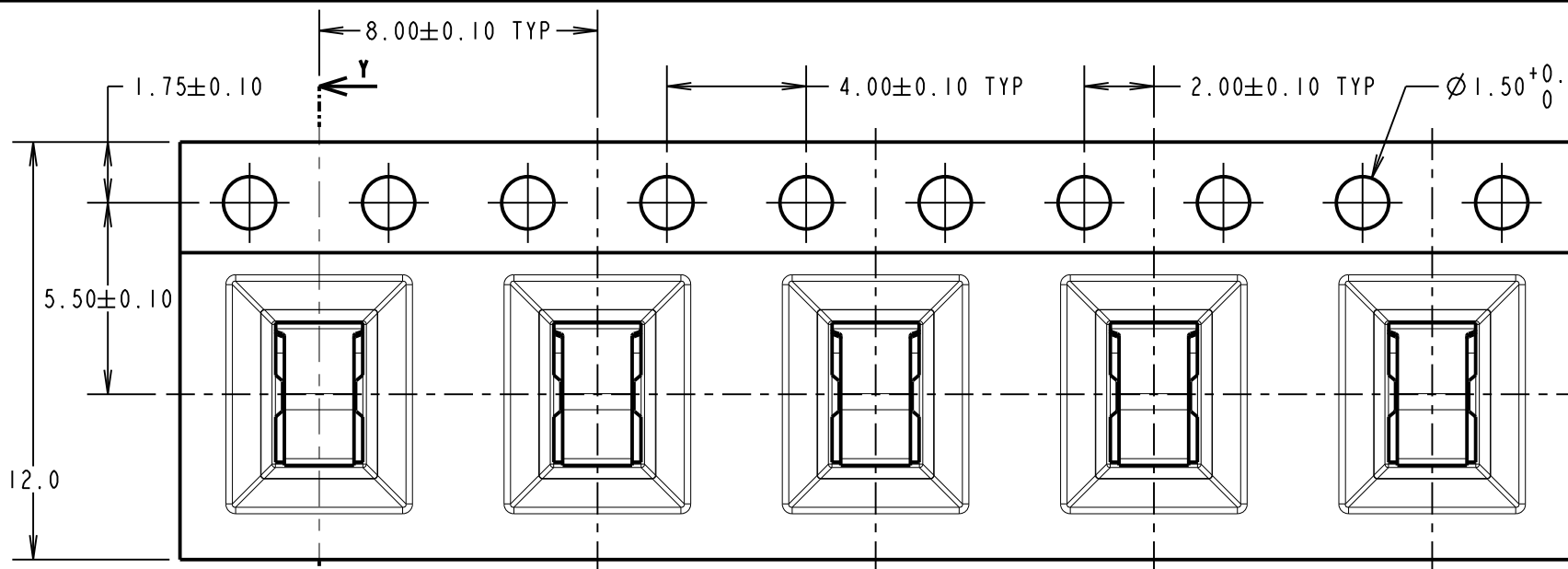

NOTES:  
 1. QUANTITY PER REEL = 1400  
 2. ALL TOLERANCES ARE: X.X = ±0.30mm  
 X.XX = ±0.15mm  
 UNLESS OTHERWISE STATED.

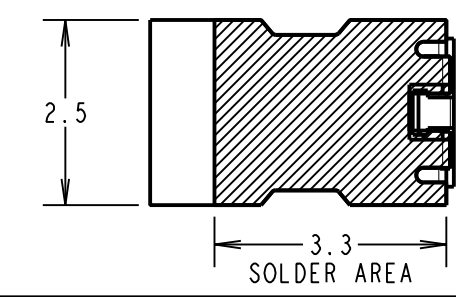

COMPONENT SPECIFICATION  
 MATERIAL = TITANIUM COPPER ALLOY, 0.10mm THICK  
 FINISH = 0.7µ - 1.3µ NICKEL, GOLD FLASH ON CONTACT  
 AND 2.54µ MIN 100% MATTE TIN ON FOOT AREA.  
 RECOMMENDED WORKING HEIGHT = 4.50mm / MIN FORCE = 1.2N  
 RECOMMENDED MINIMUM WORKING HEIGHT = 4.00mm  
 ELECTRICAL:  
 CURRENT = 4A

SB	5	07.06.13	12074
NAME	ISS.	DATE	C/NOTE
APPROVED:		S.BENNETT	
CHECKED:		M.PLESTED	
DRAWN:		R.ADDE	
CUSTOMER REF.:			
ASSEMBLY DRG:			

<p>www.harwin.com technical@harwin.com</p>	<p>THIS DRAWING AND ANY INFORMATION OR DESCRIPTIVE MATTER SET OUT HEREON ARE CONFIDENTIAL AND COPYRIGHT PROPERTY OF THE HARWIN GROUP AND MUST NOT BE DISCLOSED, LOANED, COPIED OR USED FOR MANUFACTURING, TENDERING OR FOR ANY OTHER PURPOSE WITHOUT THEIR WRITTEN PERMISSION.</p>	<p>TOLERANCES                  X = ±1mm                  X.X = ±0.25mm                  X.XX = ±0.10mm                  X.XXX = ±0.01mm                  ANGLES = ±5°                  UNLESS STATED</p>	MATERIAL: SEE ABOVE	TITLE: SMT SHIELD FINGER (6mm) IN TAPE AND REEL
			FINISH: SEE ABOVE	DRAWING NUMBER: S7051-42R
			S/AREA: mm <sup>2</sup>	SHT 2 OF 2