

## General Description

The MAX17620 evaluation kit (EV kit) is a fully assembled and tested circuit board that demonstrates the performance of the MAX17620 high-frequency, miniature 600mA step-down DC-DC converter. The EV kit is preset for 1.8V output at load currents up to 600mA. The EV kit features selectable forced-PWM/skip mode, open-drain PGOOD signal, and external enable (EN).

## Features

- 2.7V to 5.5V Input Voltage Range
- 1.8V Preset Output, Up to 600mA Continuous Current
- Fixed 4MHz Switching Frequency
- Internal Compensation
- External EN for On/Off Control
- 91% Peak Efficiency
- Selectable Forced-PWM/Skip Mode
- Brick Wall Current-Limit Protection
- Open-Drain PGOOD output
- Thermal Shutdown
- Proven PCB Layout
- Fully Assembled and Tested

[Ordering Information](#) appears at end of data sheet.

## Quick Start

### Recommended Equipment

- MAX17620 EV kit
- 2.7V to 5.5V, 600mA DC Power Supply
- Load capable of sinking 600mA
- Digital voltmeter (DVM)

### Procedure

The EV kit is fully assembled and tested. Follow the steps below to verify board operation. **Caution: Do not turn on power supply until all connections are completed.**

- 1) Verify that shunt is placed across 1-2 on JU1.
- 2) Select the shunt position on JU2 according to the intended mode of operation (see [Table 2](#) for details).
- 3) Disable the power supply. Set the power supply at a voltage between 2.7V and 5.5V.
- 4) Connect the positive terminal of the power supply to the IN PCB pad and the ground terminal of the power supply to the nearest GND PCB pad.
- 5) Connect the DVM across the VOUT and GND PCB pads with the positive polarity of the DVM connected to the VOUT PCB pad.
- 6) Turn on the power supply and verify that the DVM displays 1.8V.
- 7) Connect the positive terminal of the load to the VOUT PCB pad and ground terminal of the load to the nearest GND PCB pad in the case of an electronic load. For resistive load, connect the load resistor across the VOUT and GND PCB pads.
- 8) Turn on the load and verify that the DVM still displays 1.8V.

### Detailed Description

The MAX17620 EV kit is a fully assembled and tested circuit board that demonstrates the performance of the MAX17620 high-frequency, miniature 600mA step-down DC-DC converter. The EV kit is preset for 1.8V output at load currents up to 600mA.

The EV kit includes an EN PCB pad and jumper JU1 to enable/disable the output. Jumper JU2 allows the selection of a particular mode of operation under light loads among forced-PWM and skip modes. An additional PGOOD PCB pad is available for monitoring whether or not the converter output voltage is in regulation.

#### Enable Control (JU1)

The EN pin of the device serves as an on/off control. Install a shunt across pins 1-2 on jumper JU1 to enable the EV kit's output. See [Table 1](#) for proper jumper settings.

#### Mode Selection (JU2)

The device's MODE pin can be used to select among forced PWM and skip mode under light loads. Refer to

**Table 1. Enable Control (JU1)**

SHUNT POSITION	EN PIN	EV KIT'S OUTPUT
1-2*	Connected to IN	Enabled
2-3	Connected to GND	Disabled

\*Default position.

**Table 2. MODE Selection (JU2)**

SHUNT POSITION	MODE PIN	MODE OF OPERATION
1-2	Connected to IN	Skip Mode
2-3	Connected to GND	Forced-PWM Mode
Open*	Unconnected	Skip Mode

\*Default position.

the MAX17620 IC data sheet for more information on forced-PWM and skip modes of operation. [Table 2](#) shows EV kit jumper JU2 settings that can be used to configure the desired mode of operation.

#### Adjusting Output Voltage

The EV kit supports output voltages from 1.5V to 3.4V. Resistors R1 and R2 are chosen to be 24kΩ and 19.1kΩ, respectively, to provide a preset output voltage of 1.8V. The output voltage can be adjusted by keeping R1 fixed at 24kΩ and changing R2 using the following equation:

$$R2 = \frac{R1}{\left[ \frac{V_{OUT}}{0.8} - 1 \right]}$$

[Table 3](#) summarizes R1 and R2 values needed to configure the EV kit output for commonly found supply rails.

**Table 3. Adjusting Output Voltage (R1, R2)**

R1 (kΩ)	R2 (kΩ)	OUTPUT VOLTAGE (V)
24*	27.4	1.5
24*	19.1	1.8
24*	16	2.0
24*	11.3	2.5
24*	8.66	3.0
24*	7.68	3.3
24*	7.41	3.4

\*Default value.

EV Kit Performance

( $V_{IN} = 3.6V$ ,  $T_A = +25^{\circ}C$ , unless otherwise noted.)

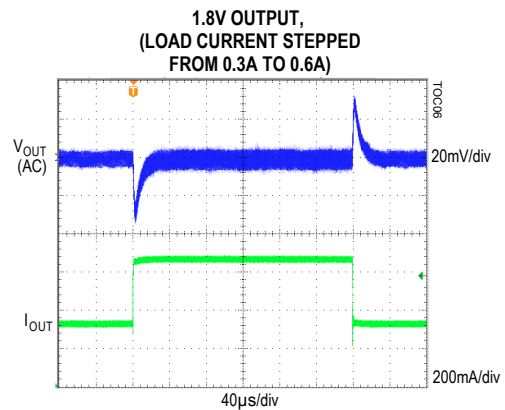
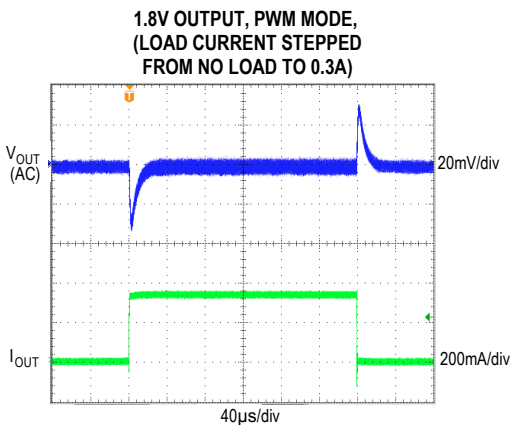
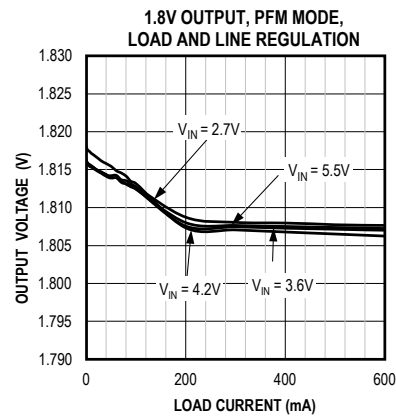
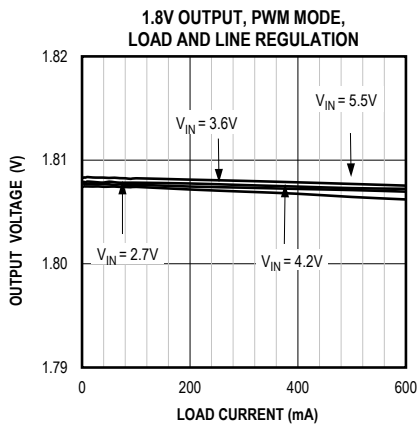
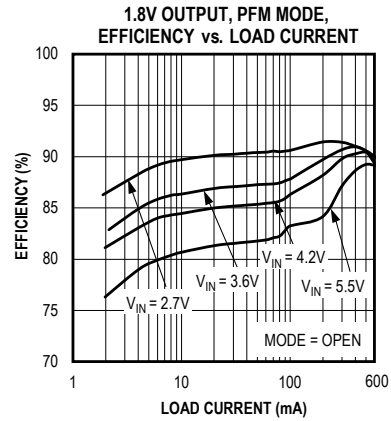
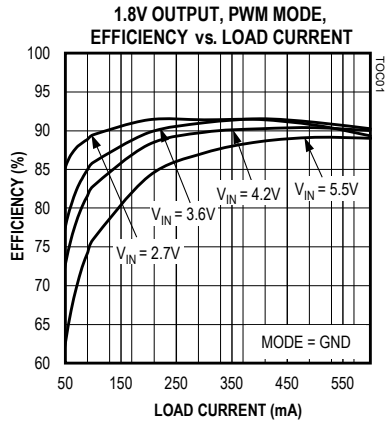

### EV Kit Performance (continued)

( $V_{IN} = 3.6V$ ,  $T_A = +25^\circ C$ , unless otherwise noted.)

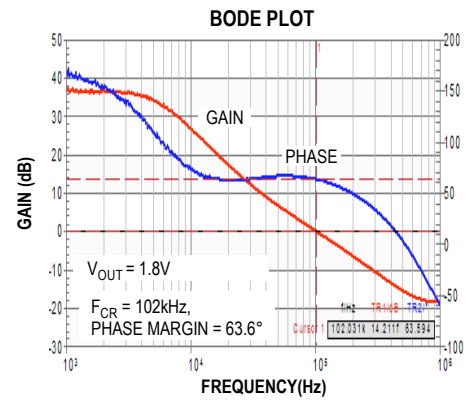
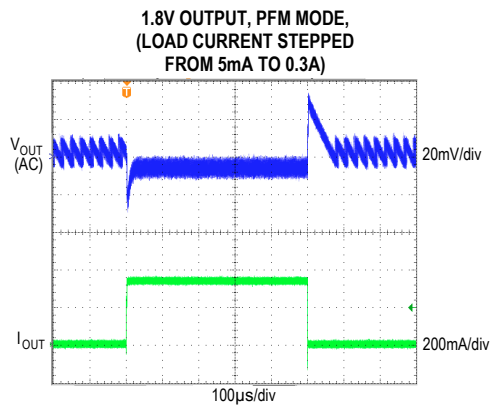

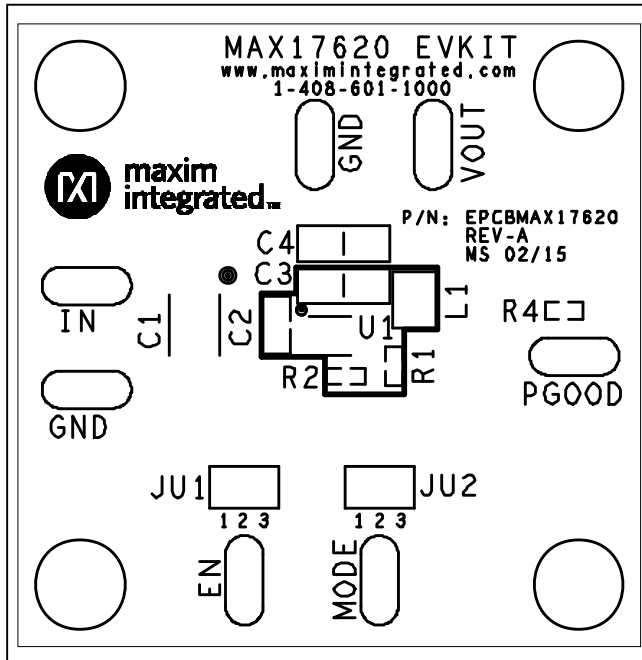

Figure 1. MAX17620 EV Kit Component Placement Guide—Component Side

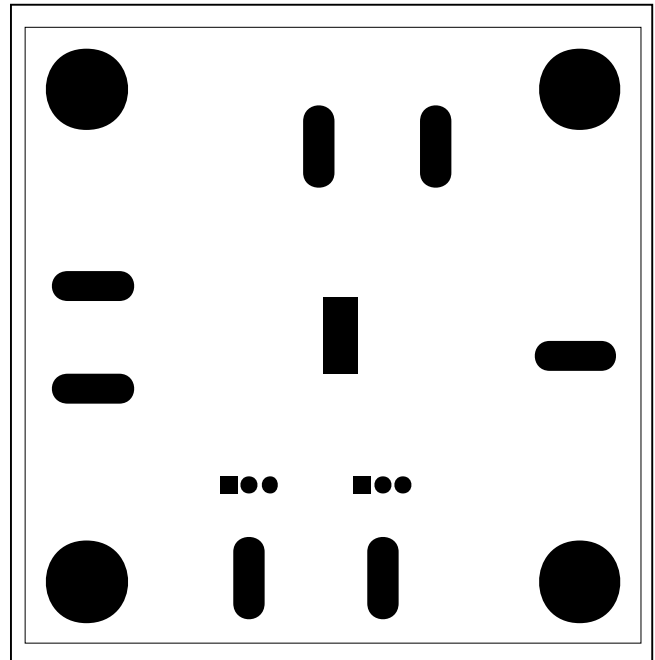

Figure 2. MAX17620 EV Kit Solder Mask—Solder Side

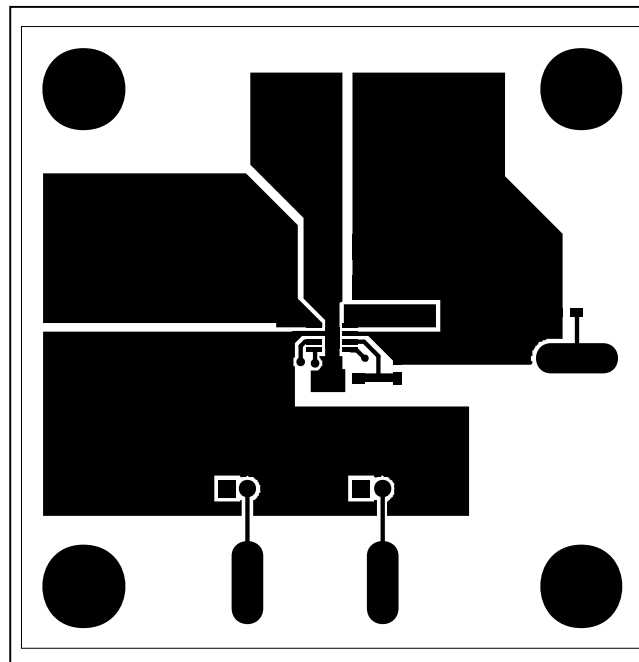

Figure 3. MAX17620 EV Kit PCB Layout—Component Side

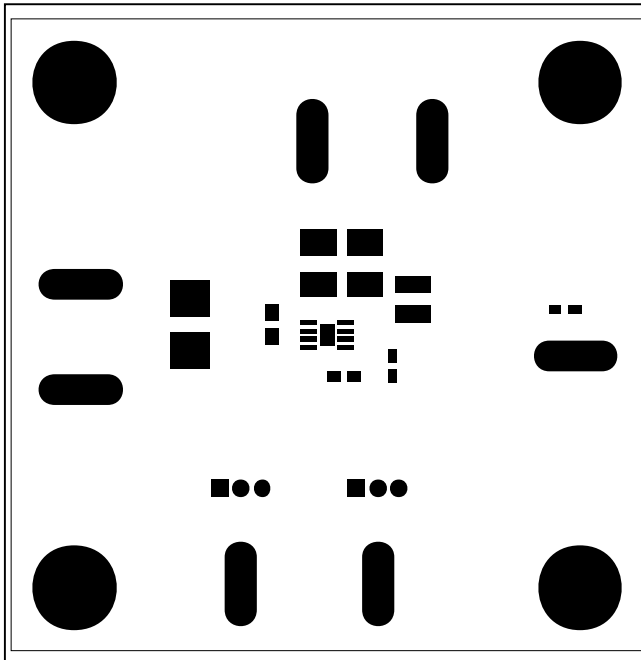

Figure 4. MAX17620 EV Kit Solder Mask—Component Side

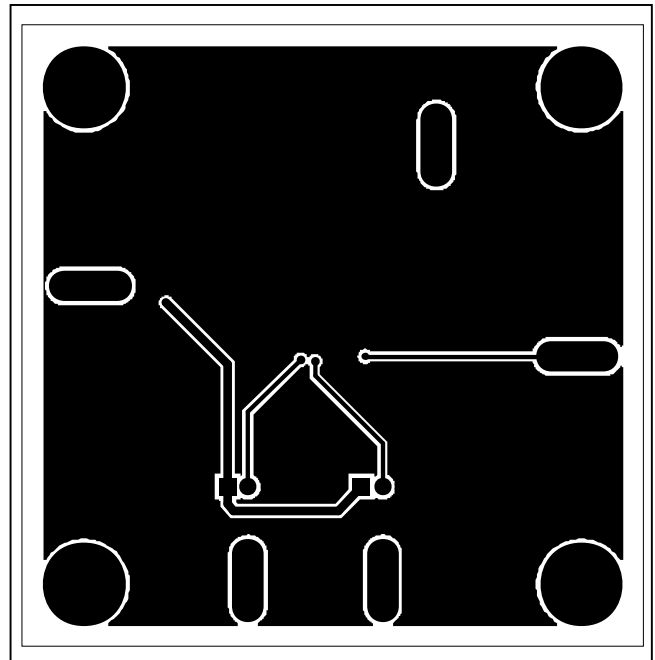

Figure 5. MAXM17543 EV Kit PCB Layout—Solder Side

### Component Suppliers

SUPPLIER	PHONE	WEBSITE
Murata Americas	800-241-6574	<a href="http://www.murataamericas.com">www.murataamericas.com</a>
Kemet	877-695-3638	<a href="http://www.kemet.com">www.kemet.com</a>
Vishay Dale	402-563-6866	<a href="http://www.vishay.com">www.vishay.com</a>

**Note:** Indicate that you are using the MAX17620 when contacting these component suppliers.

### Component List and Schematic

Refer to files “MAX17620 EV Kit BOM.xlsx” and “MAX17620 EV Kit Schematic.pdf” for component information.

### Ordering Information

PART	TYPE
MAX17620EVKIT#	EV Kit

#Denotes RoHS compliant.

### Revision History

REVISION NUMBER	REVISION DATE	DESCRIPTION	PAGES CHANGED
0	3/15	Initial release	—

For pricing, delivery, and ordering information, please contact Maxim Direct at 1-888-629-4642, or visit Maxim Integrated's website at [www.maximintegrated.com](http://www.maximintegrated.com).

*Maxim Integrated cannot assume responsibility for use of any circuitry other than circuitry entirely embodied in a Maxim Integrated product. No circuit patent licenses are implied. Maxim Integrated reserves the right to change the circuitry and specifications without notice at any time.*



# Mouser Electronics

Authorized Distributor

Click to View Pricing, Inventory, Delivery & Lifecycle Information:

[Maxim Integrated:](#)

[MAX17620EVKIT#](#)