



**MICROCHIP**

---

**10-Pin MSOP and 8-Pin MSOP  
Evaluation Board  
User's Guide**

---

---

**Note the following details of the code protection feature on Microchip devices:**

- Microchip products meet the specification contained in their particular Microchip Data Sheet.
- Microchip believes that its family of products is one of the most secure families of its kind on the market today, when used in the intended manner and under normal conditions.
- There are dishonest and possibly illegal methods used to breach the code protection feature. All of these methods, to our knowledge, require using the Microchip products in a manner outside the operating specifications contained in Microchip's Data Sheets. Most likely, the person doing so is engaged in theft of intellectual property.
- Microchip is willing to work with the customer who is concerned about the integrity of their code.
- Neither Microchip nor any other semiconductor manufacturer can guarantee the security of their code. Code protection does not mean that we are guaranteeing the product as "unbreakable."

Code protection is constantly evolving. We at Microchip are committed to continuously improving the code protection features of our products. Attempts to break Microchip's code protection feature may be a violation of the Digital Millennium Copyright Act. If such acts allow unauthorized access to your software or other copyrighted work, you may have a right to sue for relief under that Act.

---

Information contained in this publication regarding device applications and the like is provided only for your convenience and may be superseded by updates. It is your responsibility to ensure that your application meets with your specifications. MICROCHIP MAKES NO REPRESENTATIONS OR WARRANTIES OF ANY KIND WHETHER EXPRESS OR IMPLIED, WRITTEN OR ORAL, STATUTORY OR OTHERWISE, RELATED TO THE INFORMATION, INCLUDING BUT NOT LIMITED TO ITS CONDITION, QUALITY, PERFORMANCE, MERCHANTABILITY OR FITNESS FOR PURPOSE. Microchip disclaims all liability arising from this information and its use. Use of Microchip devices in life support and/or safety applications is entirely at the buyer's risk, and the buyer agrees to defend, indemnify and hold harmless Microchip from any and all damages, claims, suits, or expenses resulting from such use. No licenses are conveyed, implicitly or otherwise, under any Microchip intellectual property rights unless otherwise stated.

*Microchip received ISO/TS-16949:2009 certification for its worldwide headquarters, design and wafer fabrication facilities in Chandler and Tempe, Arizona; Gresham, Oregon and design centers in California and India. The Company's quality system processes and procedures are for its PIC® MCUs and dsPIC® DSCs, KEELOQ® code hopping devices, Serial EEPROMs, microperipherals, nonvolatile memory and analog products. In addition, Microchip's quality system for the design and manufacture of development systems is ISO 9001:2000 certified.*

**QUALITY MANAGEMENT SYSTEM  
CERTIFIED BY DNV  
= ISO/TS 16949 =**

### Trademarks

The Microchip name and logo, the Microchip logo, AnyRate, AVR, AVR logo, AVR Freaks, BeaconThings, BitCloud, CryptoMemory, CryptoRF, dsPIC, FlashFlex, flexPWR, Helder, JukeBlox, KEELOQ, KEELOQ logo, Klear, LANCheck, LINK MD, maXStylus, maXTouch, MediaLB, megaAVR, MOST, MOST logo, MPLAB, OptoLyzer, PIC, picoPower, PICSTART, PIC32 logo, Prochip Designer, QTouch, RightTouch, SAM-BA, SpyNIC, SST, SST Logo, SuperFlash, tinyAVR, UNI/O, and XMEGA are registered trademarks of Microchip Technology Incorporated in the U.S.A. and other countries.

ClockWorks, The Embedded Control Solutions Company, EtherSynch, Hyper Speed Control, HyperLight Load, IntelliMOS, mTouch, Precision Edge, and Quiet-Wire are registered trademarks of Microchip Technology Incorporated in the U.S.A.

Adjacent Key Suppression, AKS, Analog-for-the-Digital Age, Any Capacitor, AnyIn, AnyOut, BodyCom, chipKIT, chipKIT logo, CodeGuard, CryptoAuthentication, CryptoCompanion, CryptoController, dsPICDEM, dsPICDEM.net, Dynamic Average Matching, DAM, ECAN, EtherGREEN, In-Circuit Serial Programming, ICSP, Inter-Chip Connectivity, JitterBlocker, KlearNet, KlearNet logo, Mindi, MiWi, motorBench, MPASM, MPF, MPLAB Certified logo, MPLIB, MPLINK, MultiTRAK, NetDetach, Omniscient Code Generation, PICDEM, PICDEM.net, PICkit, PICtail, PureSilicon, QMatrix, RightTouch logo, REAL ICE, Ripple Blocker, SAM-ICE, Serial Quad I/O, SMART-I.S., SQI, SuperSwitcher, SuperSwitcher II, Total Endurance, TSHARC, USBCheck, VariSense, ViewSpan, WiperLock, Wireless DNA, and ZENA are trademarks of Microchip Technology Incorporated in the U.S.A. and other countries.

SQTP is a service mark of Microchip Technology Incorporated in the U.S.A.

Silicon Storage Technology is a registered trademark of Microchip Technology Inc. in other countries.

GestIC is a registered trademark of Microchip Technology Germany II GmbH & Co. KG, a subsidiary of Microchip Technology Inc., in other countries.

All other trademarks mentioned herein are property of their respective companies.

© 2017, Microchip Technology Incorporated, All Rights Reserved.  
ISBN: 978-1-5224-1638-8



# 10-PIN MSOP AND 8-PIN MSOP EVALUATION BOARD USER'S GUIDE

---

---

## Table of Contents

---

---

<b>Preface</b> .....	<b>7</b>
Introduction.....	7
Document Layout .....	7
Conventions Used in This Guide.....	8
Recommended Reading.....	8
The Microchip Web Site .....	9
Customer Support .....	9
Revision History .....	9
<b>Chapter 1. Product Overview</b>	
1.1 Introduction .....	11
1.2 What is the 10-Pin MSOP and 8-Pin MSOP Evaluation Board? .....	11
1.3 10-Pin MSOP and 8-Pin MSOP Evaluation Board Features .....	12
1.4 What the 10-Pin MSOP and 8-Pin MSOP Evaluation Board Kit Contains .....	12
<b>Chapter 2. Installation and Operation</b>	
2.1 Introduction .....	13
2.2 Getting Started .....	14
2.3 Hardware Description .....	16
2.4 10-Pin MSOP and 8-Pin MSOP Evaluation Board Description .....	19
2.4.1 Power and Ground .....	19
2.4.2 PCB Pads .....	19
2.4.3 Passive Components - RUx, RDx, RSx, C1 and C2 .....	20
2.4.4 Multiplexing Resistor R1 .....	20
2.4.5 Device Footprints .....	21
2.4.6 PICkit™ Serial or In-Circuit Serial Programming (ICSP) Interface (Header J1) .....	22
2.4.7 Board Interconnect Header (Header J2) .....	23
2.5 Evaluating the MCP48FEBXX Digital-to-Analog Converters .....	24
2.6 Evaluating the 45X1 Digital Potentiometers .....	26
2.6.1 Evaluating the PIC12F1572 Device (XLP PIC Microcontroller) .....	27
2.7 Creating a System with a PIC12F1572 Microcontroller and a MCP48FEB22 DAC .....	29

---

---

## Appendix A. Schematic and Layouts

A.1 Introduction .....	31
A.2 Schematics and PCB Layout .....	31
A.3 Board – Schematic .....	32
A.4 Board – Top Silk Layer .....	33
A.5 <b>Board – Top Copper and Silk Layer</b> .....	34
A.6 Board – Top Copper .....	35
A.7 Board – Bottom Copper Layer .....	36
A.8 Board – Bottom Copper and Silk Layer .....	37
A.9 Board – Bottom Silk Layer .....	38
<b>Worldwide Sales and Service .....</b>	<b>41</b>

## Object of Declaration: 10-Pin MSOP and 8-Pin MSOP Evaluation Board User's Guide

### EU Declaration of Conformity

This declaration of conformity is issued by the manufacturer.

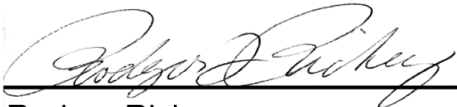
The development/evaluation tool is designed to be used for research and development in a laboratory environment. This development/evaluation tool is not a Finished Appliance, nor is it intended for incorporation into Finished Appliances that are made commercially available as single functional units to end users under EU EMC Directive 2004/108/EC and as supported by the European Commission's Guide for the EMC Directive 2004/108/EC (8th February 2010).

This development/evaluation tool complies with EU RoHS2 Directive 2011/65/EU.

This development/evaluation tool, when incorporating wireless and radio-telecom functionality, is in compliance with the essential requirement and other relevant provisions of the R&TTE Directive 1999/5/EC and the FCC rules as stated in the declaration of conformity provided in the module datasheet and the module product page available at [www.microchip.com](http://www.microchip.com).

For information regarding the exclusive, limited warranties applicable to Microchip products, please see Microchip's standard terms and conditions of sale, which are printed on our sales documentation and available at [www.microchip.com](http://www.microchip.com).

Signed for and on behalf of Microchip Technology Inc. at Chandler, Arizona, USA.



Rodger Richey  
Director of Development Tools



Date

# 10-Pin MSOP and 8-Pin MSOP Evaluation Board User's Guide

---

---

NOTES:



# 10-PIN MSOP AND 8-PIN MSOP EVALUATION BOARD USER'S GUIDE

---

---

## Preface

---

---

### NOTICE TO CUSTOMERS

All documentation becomes dated, and this manual is no exception. Microchip tools and documentation are constantly evolving to meet customer needs, so some actual dialogs and/or tool descriptions may differ from those in this document. Please refer to our web site ([www.microchip.com](http://www.microchip.com)) to obtain the latest documentation available.

Documents are identified with a “DS” number. This number is located on the bottom of each page, in front of the page number. The numbering convention for the DS number is “DSXXXXXXXXA”, where “XXXXXXXX” is the document number and “A” is the revision level of the document.

For the most up-to-date information on development tools, see the MPLAB® IDE online help. Select the Help menu, and then Topics to open a list of available online help files.

## INTRODUCTION

This chapter contains general information that will be useful to know before using the 10-Pin MSOP and 8-Pin MSOP Evaluation Board. Items discussed in this chapter include:

- Document Layout
- Conventions Used in This Guide
- Recommended Reading
- The Microchip Web Site
- Customer Support
- Revision History

## DOCUMENT LAYOUT

This document describes how to use the 10-Pin MSOP and 8-Pin MSOP Evaluation Board. The document is organized as follows:

- **Chapter 1. “Product Overview”**– Important information about the 10-Pin MSOP and 8-Pin MSOP Evaluation Board.
- **Chapter 2. “Installation and Operation”** – Includes instructions on how to get started with this evaluation board.
- **Appendix A. “Schematic and Layouts”** – Shows the schematic and layout diagrams for 10-Pin MSOP and 8-Pin MSOP Evaluation Board.

## CONVENTIONS USED IN THIS GUIDE

This manual uses the following documentation conventions:

### DOCUMENTATION CONVENTIONS

Description	Represents	Examples
<b>Arial font:</b>		
Italic characters	Referenced books	<i>MPLAB<sup>®</sup> IDE User's Guide</i>
	Emphasized text	...is the <i>only</i> compiler...
Initial caps	A window	the Output window
	A dialog	the Settings dialog
	A menu selection	select Enable Programmer
Quotes	A field name in a window or dialog	"Save project before build"
Underlined, Italic text with right angle bracket	A menu path	<u><i>File&gt;Save</i></u>
Bold characters	A dialog button	Click <b>OK</b>
	A tab	Click the <b>Power</b> tab
N'Rnnnn	A number in verilog format, where N is the total number of digits, R is the radix and n is a digit.	4'b0010, 2'hF1
Text in angle brackets < >	A key on the keyboard	Press <Enter>, <F1>
<b>Courier New font:</b>		
Plain Courier New	Sample source code	#define START
	Filenames	autoexec.bat
	File paths	c:\mcc18\h
	Keywords	_asm, _endasm, static
	Command-line options	-Opa+, -Opa-
	Bit values	0, 1
	Constants	0xFF, 'A'
Italic Courier New	A variable argument	<i>file.o</i> , where <i>file</i> can be any valid filename
Square brackets [ ]	Optional arguments	mcc18 [options] <i>file</i> [options]
Curly brackets and pipe character: {   }	Choice of mutually exclusive arguments; an OR selection	errorlevel {0 1}
Ellipses...	Replaces repeated text	var_name [, var_name...]
	Represents code supplied by user	void main (void) { ... }



## RECOMMENDED READING

This user's guide describes how to use 10-Pin MSOP and 8-Pin MSOP Evaluation Board. The following Microchip documents are available and recommended as supplemental reference resources:

- **MCP48FEB22-E/UN Data Sheet - “8-/10-/12-Bit Single/Dual Voltage Output Nonvolatile Digital-to-Analog Converters with SPI Interface” (DS20005429)**
- **MCP41x1 Data Sheet - “7/8-Bit Single/Dual SPI Digital POT with Non-Volatile Memory” (DS22059)**
- **PIC12F1572 Data Sheet – “8-Pin MCU with High-Precision 16-Bit PWMs” (DS40001723)**

## THE MICROCHIP WEB SITE

Microchip provides online support via our web site at [www.microchip.com](http://www.microchip.com). This web site is used as a means to make files and information easily available to customers. Accessible by using your favorite Internet browser, the web site contains the following information:

- **Product Support** – Data sheets and errata, application notes and sample programs, design resources, user's guides and hardware support documents, latest software releases and archived software
- **General Technical Support** – Frequently Asked Questions (FAQs), technical support requests, online discussion groups, Microchip consultant program member listing
- **Business of Microchip** – Product selector and ordering guides, latest Microchip press releases, listing of seminars and events, listings of Microchip sales offices, distributors and factory representatives.

## CUSTOMER SUPPORT

Users of Microchip products can receive assistance through several channels:

- Distributor or Representative
- Local Sales Office
- Field Application Engineer (FAE)
- Technical Support

Customers should contact their distributor, representative or field application engineer (FAE) for support. Local sales offices are also available to help customers. A listing of sales offices and locations is included in the back of this document.

Technical support is available through the web site at:

<http://www.microchip.com/support>.

## REVISION HISTORY

### Revision A (April 2017)

- Original Release of this Document.

NOTES:

## Chapter 1. Product Overview

### 1.1 INTRODUCTION

This chapter provides an overview of the 10-Pin MSOP and 8-Pin MSOP Evaluation Board and covers the following topics:

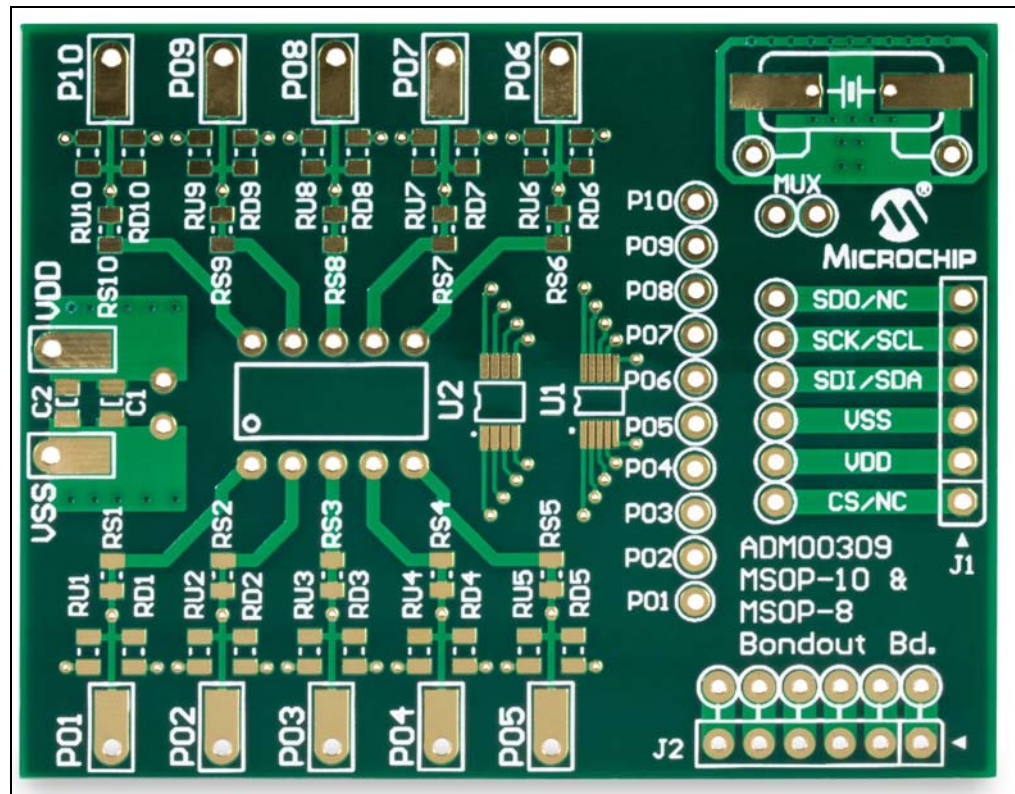
- What is the 10-Pin MSOP and 8-Pin MSOP Evaluation Board?
- 10-Pin MSOP and 8-Pin MSOP Evaluation Board Features
- What the 10-Pin MSOP and 8-Pin MSOP Evaluation Board Kit Contains

### 1.2 WHAT IS THE 10-PIN MSOP AND 8-PIN MSOP EVALUATION BOARD?

The 10-Pin MSOP and 8-Pin MSOP Evaluation Board (Figure 1-1) is a bond-out board that allows the system designer to quickly evaluate the operation of Microchip Technology's devices in any of the following packages:

- MSOP (8- and 10-pin)
- DIP (10-pin)

**Note:** The 10-Pin MSOP and 8-Pin MSOP Evaluation Board can be used as an MSOP to DIP converter.



**FIGURE 1-1:** 10-Pin MSOP and 8-Pin MSOP Evaluation Board Overview.

## 1.3 10-PIN MSOP AND 8-PIN MSOP EVALUATION BOARD FEATURES

The MSOP-10 and MSOP-8 Evaluation Board has the following features:

- Connection terminals may be either through-hole or surface-mount
- The three types of supported footprints are:
  - MSOP-10
  - MSOP-8
  - DIP-10
- Footprints for optional passive components (SMT [0805] footprint) for:
  - Power supply filtering
  - Device bypass capacitor
  - Filtering
  - Pull-up resistor
  - Pull-down resistor
  - Loading resistor
  - In-line resistor
  - Crystal oscillator capacitors
- Silk-screen area to write specifics of implemented circuit (on back of PCB), such as MCP48FEB22-E/UN.
- PICKit™ Serial Analyzer and/or PICKit Programming (ICSP™) Header
- Crystal/ceramic resonator circuit footprints, SMT and THT
- Second 1 x 6 in-line connector header for interfacing to boards with PICKit Serial Analyzer header.

Some of the Microchip family of devices that can be evaluated in the PCB include:

- Digital Potentiometers (Digi-pots)
- DAC (Digital to Analog Converters)
- PIC® microcontrollers
- Op-amps
- Real-time clock/calendar (RTCC) chips
- Temperature sensors
- Switching regulators

## 1.4 WHAT THE 10-PIN MSOP AND 8-PIN MSOP EVALUATION BOARD KIT CONTAINS?

The 10-Pin MSOP and 8-Pin MSOP Evaluation Board includes the following items:

- 10 blank Printed Circuit Boards (PCB) (ADM00309)
- Important Information Sheet



# 10-PIN MSOP AND 8-PIN MSOP EVALUATION BOARD USER'S GUIDE

---

---

## Chapter 2. Installation and Operation

---

---

### 2.1 INTRODUCTION

This blank printed circuit board allows 8- and 10-pin devices in the following package types to be installed: MSOP-10, MSOP-8 and DIP-10.

This board is generic so that any of the listed devices may be installed. Refer to the device data sheet, however, for suitability of device evaluation.

As well as the device, other desired passive components (resistors and capacitors) and connection posts may be installed. This allows the board to evaluate a minimum configuration for the device. It also allows the device to easily be jumpered into an existing system.

The board also has two 6-pin headers (1 x 6) whose signals can easily be jumpered to any of the device's pins. This allows one header to be connected for one purpose (programming) and the other for communication to another board. An example would be installing a PIC12F1572 (MSOP-8) in one PCB, where J1 is connected as the ICSP (In-circuit Serial Programming) interface, and J2 is connected to be the communication interface to the second board (PICKit Serial Analyzer interface pinout). The second board has the MCP48FEB22-E/UN device (MSOP-10) where J1 is connected for the PICKit Serial interface. This allows the PIC12F1572 board to be programmed to control the MCP48FEB22-E/UN board.

## 2.2 GETTING STARTED

The pins of the 8-pin device are tied together with the upper pins of the 10-pin device (1-4 and 7-10); see [Table 2-1](#).

**TABLE 2-1: MSOP FOOTPRINTS PIN CORRESPONDENCE**

MSOP—10	MSOP—8	Comments
1	1	
2	2	
3	3	
4	4	
5	—	
6	—	
7	5	
8	6	
9	7	
10	8	

The pads' indexes correspond to the MSOP-10 pin indexes. For example, pad P05 is connected to the pin 5 of the MSOP-10 package.

The footprints for the pull-up (RUX), pull-down (RDx) and series (RSx) devices are labeled in relation to the MSOP-10 package. For example, pin 1 is connected to RU1, RD1 and RS1.

This circuit allows each pin to individually have any of the following: a pull-up resistor, a pull-down resistor (or a loading/filtering capacitor) and a series resistor.

Power supply filtering capacitors are connected between the  $V_{DD}$  and  $V_{SS}$  pads (C1 and C2). The circuit has two 6-pin headers that can be used for PICkit Serial communication as well as PIC ICSP, or to connect two evaluation board together. The signals of the headers need to be jumpered to the appropriate device pins.

Figure 2-1 shows the evaluation board circuit, and an example of connecting signals from the J1 header to the device pins with jumper wire.

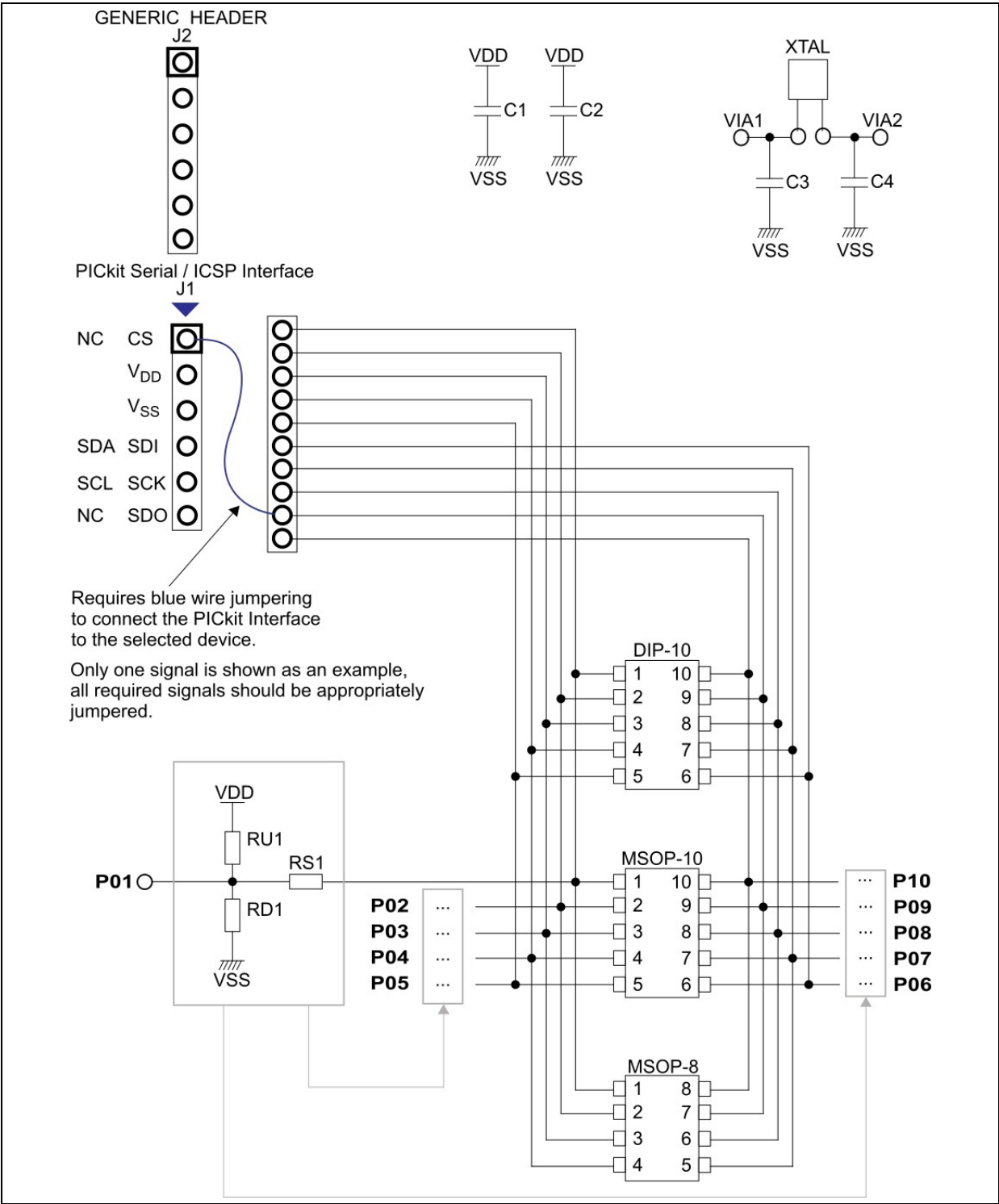


FIGURE 2-1: 10-Pin MSOP and 8-Pin MSOP Evaluation Board Circuit.

## 2.3 HARDWARE DESCRIPTION

Figure 2-2 and Figure 2-3 show the top side and bottom side of the component layout of the 10-Pin MSOP and 8-Pin MSOP Evaluation Board.

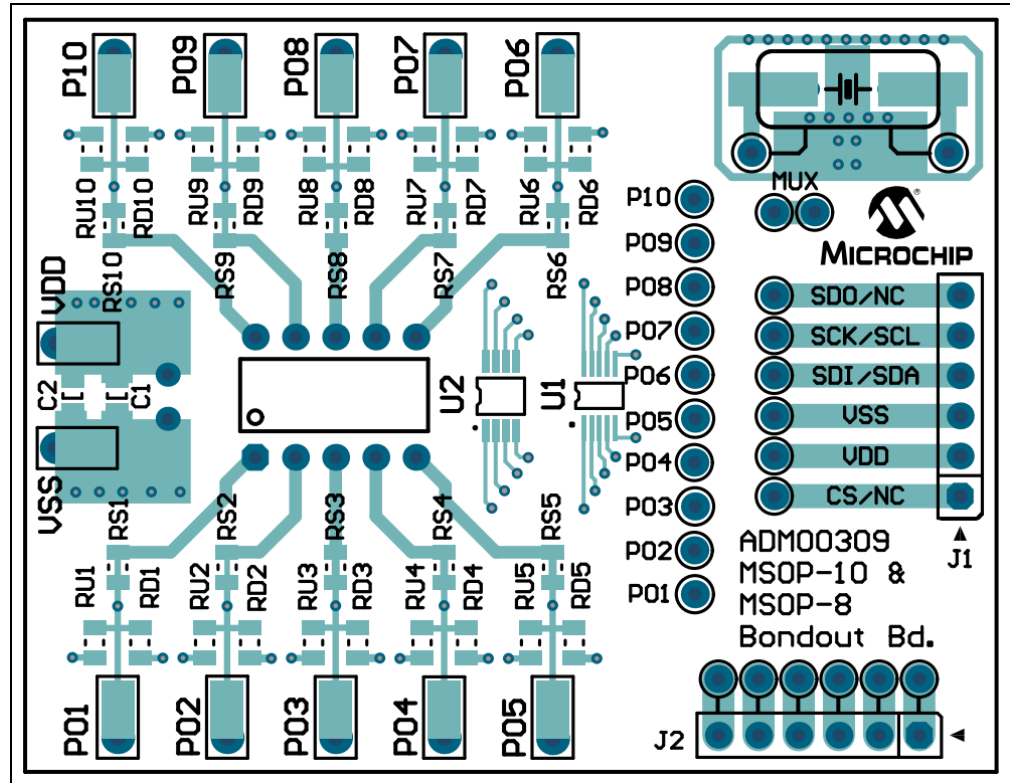


FIGURE 2-2: 10-Pin MSOP and 8-Pin MSOP Evaluation Board - Top View.

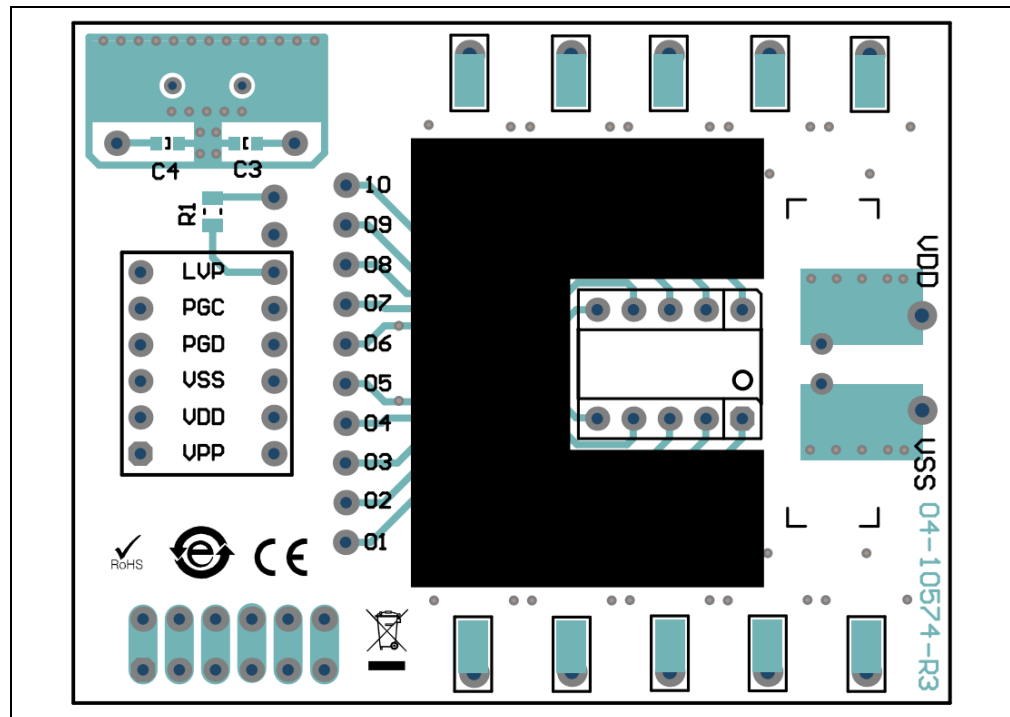


FIGURE 2-3: 10-Pin MSOP and 8-Pin MSOP Evaluation Board - Bottom View.



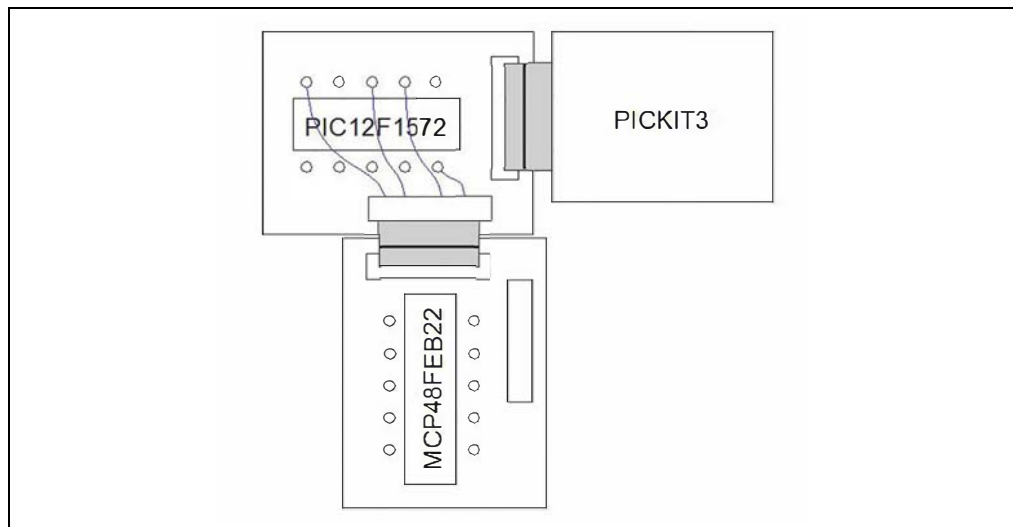
The 10-Pin MSOP and 8-Pin MSOP Evaluation Board is a four-layer board (62 mm x 48 mm). There are ten connection points/pads that can use either through-hole or surface-mount connector posts.

The pad labeled  $V_{DD}$  is connected to the PCB power plane, while the pad labeled  $V_{SS}$  is connected to the PCB ground plane. All the passive components that are connected to  $V_{DD}$  or  $V_{SS}$  are connected to either the power plane or ground plane. The 10 remaining PCB pads correspond to the device pins (e.g., pad 1 connects to pin1).

Each pad has three passive components associated with them: a pull-up resistor, a pull-down resistor and an in line series resistor. The pull-up resistor is always  $RU_x$  and the pull-down resistor is  $RD_x$ . The "X" is a numeric value that corresponds to a particular pad (1 to 8). As an example, Pad 5's pull-up resistor is  $RU_5$ . Capacitor C1 and C2 are the power supply filtering capacitors. For whichever pin is the device's  $V_{DD}$ , the  $RD_x$  component footprint can be used for the device's bypass capacitor. [Table 2-1](#) describes the components.

Two 6-pin header interfaces are available (J1 and J2). Header J1 will typically be used for the PICkit Serial or the PIC In-Circuit Serial Programming (ICSP) interface. Header J2 allows a custom interface for connecting to other boards (see [Figure 2-17](#)).

For additional information, refer to [Section 2.4.6 "PICkit Serial or In-Circuit Serial Programming \(ICSP\) Interface \(Header J1\)"](#). [Figure 2-4](#) shows an example of a Connection between two boards, one acting as a controller for the second one, which contains the device to be evaluated. Not all connections are illustrated.



**FIGURE 2-4:** Example of Two PCB System.

# 10-Pin MSOP and 8-Pin MSOP Evaluation Board User's Guide

---

The optional components of the 10-Pin MSOP and 8-Pin MSOP Evaluation Board are displayed in [Table 2-2](#).

**TABLE 2-2: OPTIONAL COMPONENTS**

Component	Comment
C1, C2	Power supply bypass capacitors
C3, C4	Crystal capacitors
RU1, RU3, RU3, RU4, RU5, RU6, RU7, RU8, RU9, RU10	Pull-up resistors
RD1, RD2, RD2, RD3, RD4, RD5, RD6, RD7, RD8, RD9, RD10	Pull-down resistors
RS1, RS2, RS3, RS4, RS5, RS6, RS7, RS8, RS9, RS10	Series resistors. When using a PIC MCU, placing a resistor in the RSx and a capacitor in the RDx locations creates a low-pass filter which can be used to generate a variable output voltage if connected to a PWM-capable pin.
R1	Used in case of devices that have multiplexed SDI/SDO pins, for example the MCP45x1
Y1	Used to generate a clock signal
J1	PICkit Serial/ICSP header
J2	Generic 6-pin header, used to connect two evaluation boards together

**Note 1:** Whichever pin is the device's  $V_{DD}$  pin, that corresponding RDx footprint can be used for the device's bypass capacitor. Example: If pin 8 is the device's  $V_{DD}$  pin, then install the bypass capacitor in the RD8 footprint.

**2:** All passive components use the surface mount [0805] footprint.

## 2.4 10-PIN MSOP AND 8-PIN MSOP EVALUATION BOARD DESCRIPTION

This section describes the working principles and limitations that should be taken into account when using the 10-Pin MSOP and 8-Pin MSOP Evaluation Board.

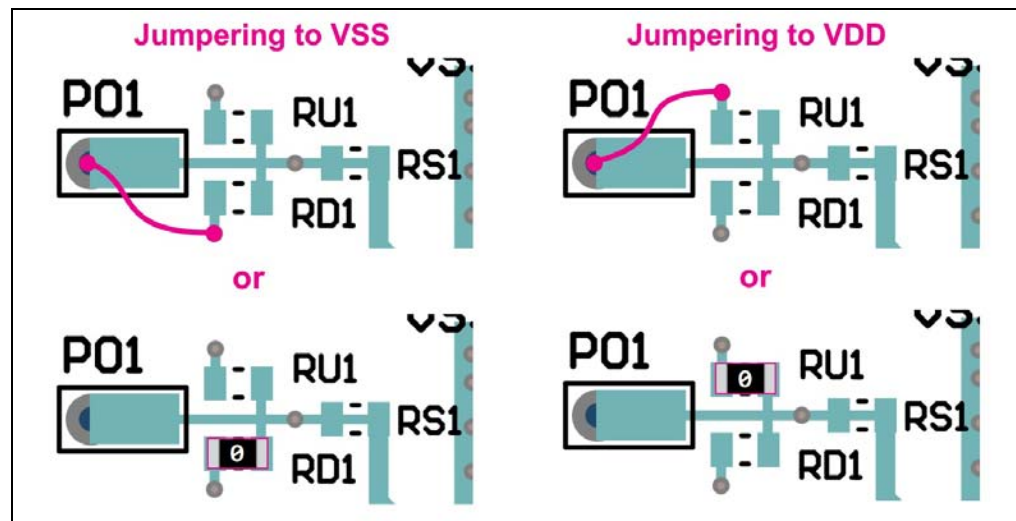
### 2.4.1 Power and Ground

The 10-Pin MSOP and 8-Pin MSOP Evaluation Board has a  $V_{DD}$  pad and a  $V_{SS}$  pad. These pads can have connection posts installed that allow easy connection to the power ( $V_{DD}$ ) and ground ( $V_{SS}$ ) planes. The layout allows either through-hole or surface-mount connectors.

The power and ground planes are connected to the appropriate passive components on the PCB (such as power plane to  $R_{UX}$  and ground plane to  $R_{DX}$  components).

### 2.4.2 PCB Pads

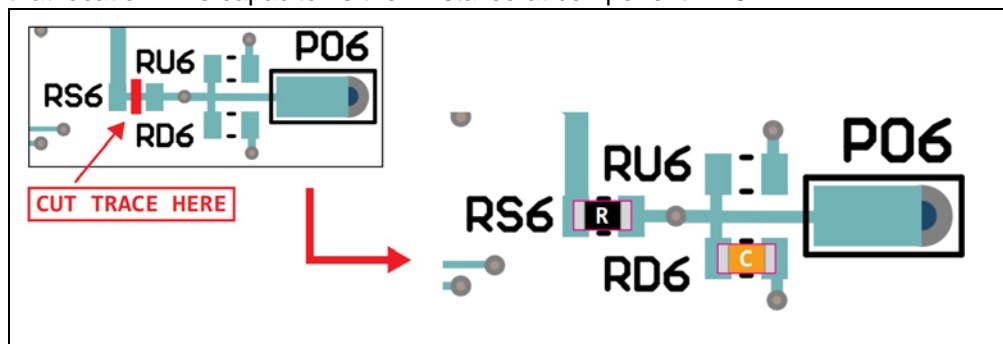
For each package pin (pins 1 to 10), there is a PCB pad (pads 1 to 10). The device has power pins ( $V_{DD}$ ) and ground pins ( $V_{SS}$ ). To ease connections on the PCB, vias to the power and ground plane have been installed close to each PCB pad. This allows any pad to be connected to the power or ground plane, so when power is connected to the  $V_{DD}$  and  $V_{SS}$  pads, it is also connected to the appropriate device pin (see [Figure 2-5](#)).



**FIGURE 2-5:** Connecting the PCB Pad to Either the  $V_{DD}$  or  $V_{SS}$  Pins.

The series components ( $R_{Sx}$ ) can be used in conjunction with the  $R_{Dx}$  components to create passive filters. For example, when using a PIC microcontroller, one could generate an analog signal by low pass-filtering the PWM signal coming from a digital output pin. In order to use the  $R_{Sx}$  footprint, the PCB trace passing through the middle of the footprint should be cut using a sharp tool.

See [Figure 2-6](#) to observe how to create an RC output filter by cutting the trace between the two Pads for component RS6 and then installing the desired resistor at that location. The capacitor is then installed at component RD6.



**FIGURE 2-6:** Creating an RC output filter

### 2.4.3 Passive Components - RUx, RDx, RSx, C1 and C2

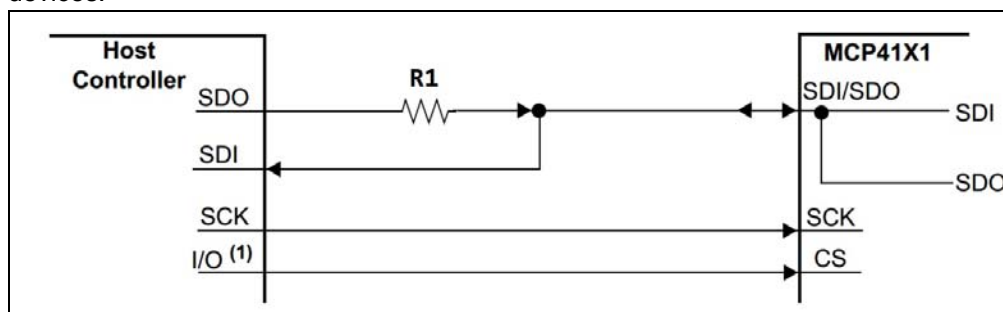
The footprints for these components allow maximum flexibility in the use of this PCB to evaluate a wide range of devices. The purpose of these components may vary depending on the device under evaluation and how it is to be used in the desired circuit. Refer to the device data sheet for the recommended components that should be used when evaluating that device.

- Component RUx allows a pull-up resistor to be installed for the device pin.
- Component RDx allows a pull-down resistor or a capacitive load/filter to be installed for the device pin.
- Component RSx allows a series component to be fitted.
- Component C1 and C2 allows power supply filtering capacitors to be installed.

### 2.4.4 Multiplexing Resistor R1

Due to the number of pins available in a specific package, some digital potentiometers multiplex together the SDI and SDO signals. It is therefore necessary to connect the two signal lines coming from the host to a single pin on the device. The digital potentiometer needs a way to overdrive the host controller's SDO signal.

[Figure 2-7](#) shows an example connection, from the MCP45x1 data sheet. The R1 value would need to be determined based on the  $V_{IH}$ ,  $V_{IL}$ ,  $V_{OH}$  and  $V_{OL}$  levels of the two devices.



**FIGURE 2-7:** Multiplexed SDI/SDO Connection Example.

## 2.4.5 Device Footprints

This section describes the characteristics of the component footprints so that you are better able to determine if the desired component(s) are compatible with the board.

### 2.4.5.1 MSOP-10

The 10-pin MSOP footprint has been laid out for packages that have a typical pitch of 0.50 BSC, a maximum lead width of 0.41 mm, and a maximum molded package width of 3 BSC. Ten-lead (or less) MSOP packages that meet these characteristics should be able to be used with this board.

### 2.4.5.2 MSOP-8

The 8-pin MSOP footprint has been laid out for packages that have a typical pitch of 0.65 mm (BSC), a maximum lead width of 0.4mm, and a maximum molded package width of 3 mm BSC. Eight-lead MSOP packages that meet these characteristics should be able to be used with this board.

### 2.4.5.3 DIP-10

The 10-pin DIP footprint has been laid out for packages that have a typical pitch of 100 mil (BSC), a maximum lead width of 22 mil and a molded package width of 600 mil.

### 2.4.5.4 PASSIVE COMPONENTS

All passive components (R1, RUx, RDx, RSx and Cx) use a surface mount [0805] footprint. Any component that has a compatible footprint can be used with this board.

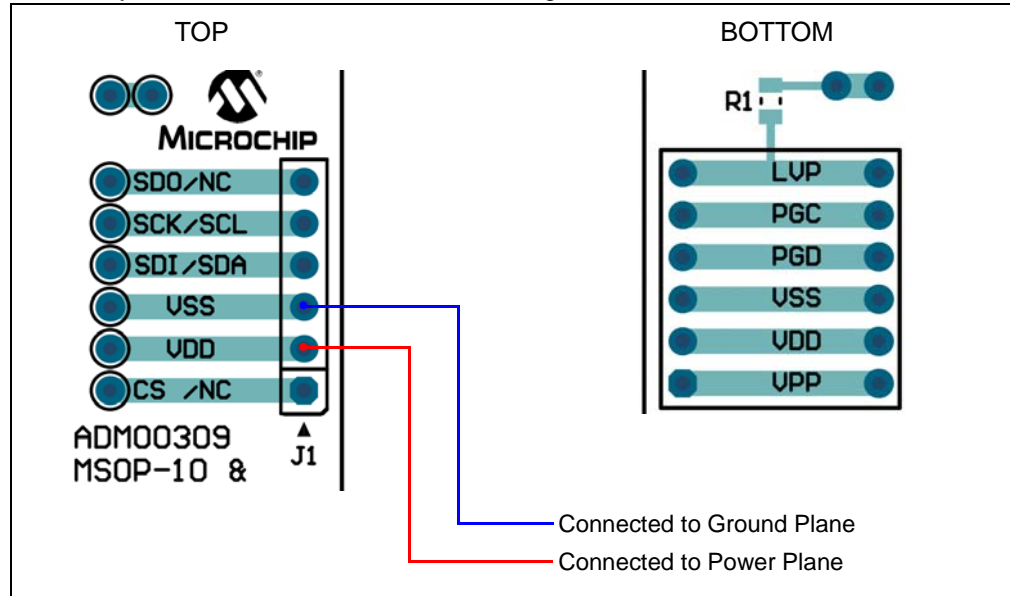
### 2.4.5.5 HEADERS (1 X 6)

The headers have a typical pitch of 100 mil (BSC). The headers are designed to be compatible with the PICKit Serial Analyzer and PICKit 3 Programmer.

## 2.4.6 PICKit Serial or In-Circuit Serial Programming (ICSP) Interface (Header J1)

Figure 2-8 shows the interface connection of the J1 Header. The  $V_{DD}$  and  $V_{SS}$  signals are connected to the appropriate power or ground plane. The other four signals are open and can be easily jumpered to any of the 10 P1 through P10 connection points.

The top layer silk screen indicates the common PICKit Serial signal names, while the bottom layer silk screen indicates the ICSP signal names.



**FIGURE 2-8:** PICKit Serial / ICSP Interface Connections.

### 2.4.6.1 PICKIT SERIAL INTERFACE

Table 2-3 shows the pin number assignment for the different signals for each of the supported interface protocols (SPI, I<sup>2</sup>C, and others).

**TABLE 2-3: PICKIT SERIAL HEADER SIGNALS**

Pin Number	PICKit Serial Header Signal				
	SPI	I <sup>2</sup> C	USART	Microwire	LIN
1	CS	—	TX	CS	TX
2	$V_{DD}$	$V_{DD}$	$V_{DD}$	$V_{DD}$	—
3	$V_{SS}$	$V_{SS}$	$V_{SS}$	$V_{SS}$	$V_{SS}$
4	SDI	SDA	—	SDI	CS/WAKE
5	SCK	SCL	—	SCK	FAULT/TXE
6	SDO	—	RX	SDO	RX

## 2.4.6.2 ICSP INTERFACE

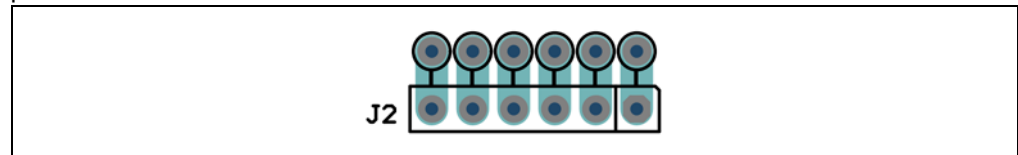
The ICSP interface allows a PIC MCU device to be programmed with programmers that support this interface, such as the PICKit 3 programmer (Part Number: PG164130). [Table 2-4](#) shows the pin number assignment for the ICSP signals.

**TABLE 2-4: ICSP HEADER SIGNALS**

Pin Number	ICSP Signal	Comments
1	VPP	High Voltage Signal
2	VDD	—
3	VSS	—
4	PCD	ICSP™ Data
5	PCC	ICSP™ Clock
6	—	—

## 2.4.7 Board interconnect header (Header J2)

[Figure 2-9](#) shows the interface connection of J2 Header. This header allows two ADM00309 boards to be inter-connected, which permits a microcontroller from one of the boards to be used as a controller for the device on the second board. The six connector signals are routed out to six holes, which should be wired to the appropriate pins.



**FIGURE 2-9:** J2 Header Connections.





Table 2-5 shows other DACs that are compatible with this evaluation board.

**TABLE 2-5: SUPPORTED DIGITAL-TO ANALOG CONVERTERS**

Device	MSOP-8	MSOP-10	Comments
MCP4801	Y	—	
MCP4802	Y	—	
MCP48FEB01	—	Y	
MCP48FEB02	—	Y	
MCP48FVB01	—	Y	
MCP48FVB02	—	Y	
MCP4901	Y	—	
TC1320	Y	—	
MCP4811	Y	—	
MCP4812	Y	—	
MCP48FEB11	—	Y	
MCP48FEB12	—	Y	
MCP48FVB11	—	Y	
MCP48FVB12	—	Y	
MCP4911	Y	—	
TC1321	Y	—	
MCP4728	—	Y	
MCP4821	Y	—	
MCP4822	Y	—	
MCP48FEB21	—	Y	
MCP48FEB22	—	Y	
MCP48FVB21	—	Y	
MCP48FVB22	—	Y	
MCP4921	Y	—	

## 2.6 EVALUATING THE 45X1 DIGITAL POTENTIOMETERS

The MCP45x1 is a family of digital potentiometers that offers 7- and 8-bit resistor networks as well as volatile and non-volatile memories options, in a MSOP 8-pin package. The MCP45X1 8-pin package is shown in Figure 2-12. The family works with an I<sup>2</sup>C serial interface with speeds of 100 kHz, 400 kHz and 3.4 MHz. The PICKit Serial Analyzer can be used to communicate with the devices. The proper connections are being shown in Figure 2-13. Other Digital Potentiometers that are supported by this evaluation board are shown in Table 2-6.

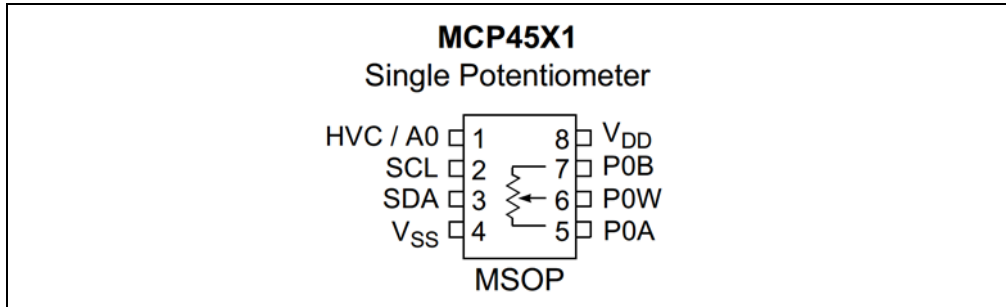


FIGURE 2-12: MCP45x1 Family Pinout.

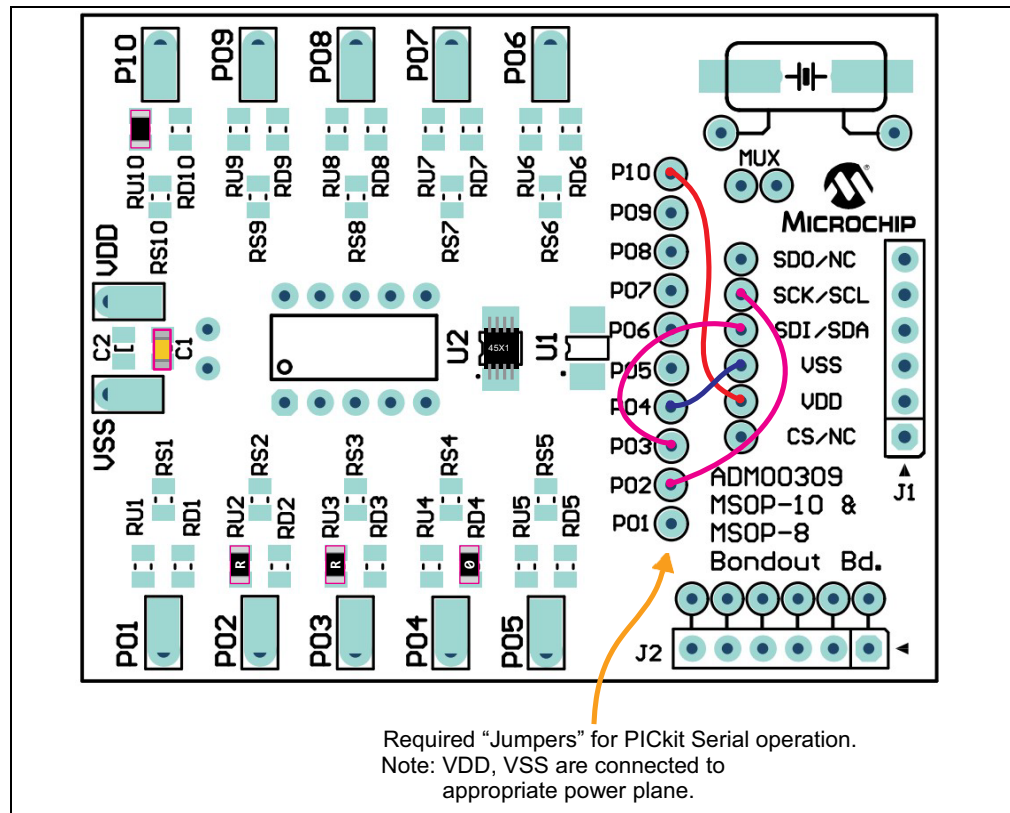


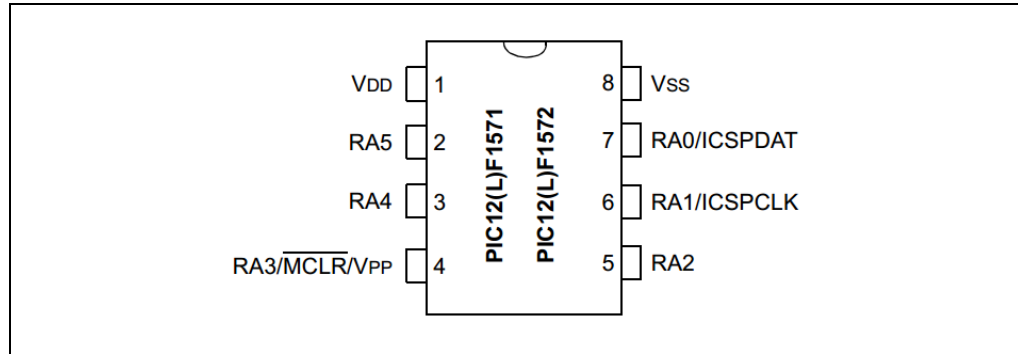
FIGURE 2-13: MCP45x1 PICKit Serial Header Example Connections.

TABLE 2-6: SUPPORTED DIGITAL POTENTIOMETER FAMILIES

Device	MSOP-8	MSOP-10	Comments
MCP413x	Y	—	
MCP41x2	Y	—	
MCP42x2	—	Y	
MCP45x1	Y	—	
MCP45x2	Y	—	
MCP46x2	—	Y	

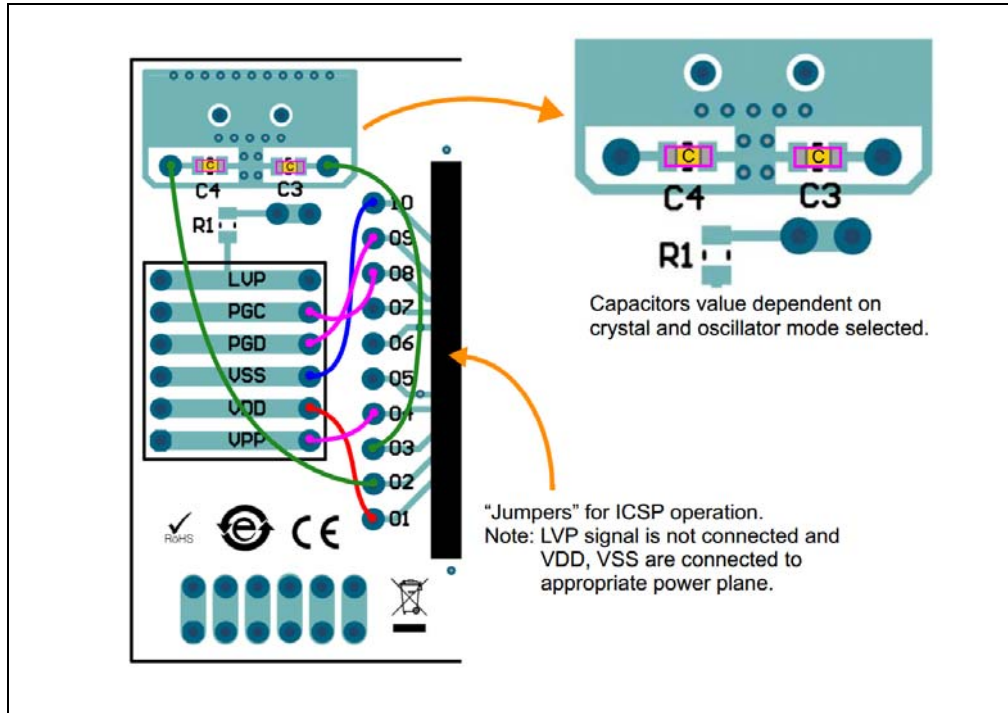
## 2.6.1 Evaluating the PIC12F1572 Device (XLP PIC Microcontroller)

The PIC12F1572 is a nanowatt XLP PIC Microcontroller that is offered in an 8-lead MSOP package. This device can be installed on the top side of the PCB. [Figure 2-14](#) shows the PIC12F1572's pin out, while [Figure 2-15](#) shows an example connection for the ICSP interface and the connection of the crystal circuit to the secondary oscillator.

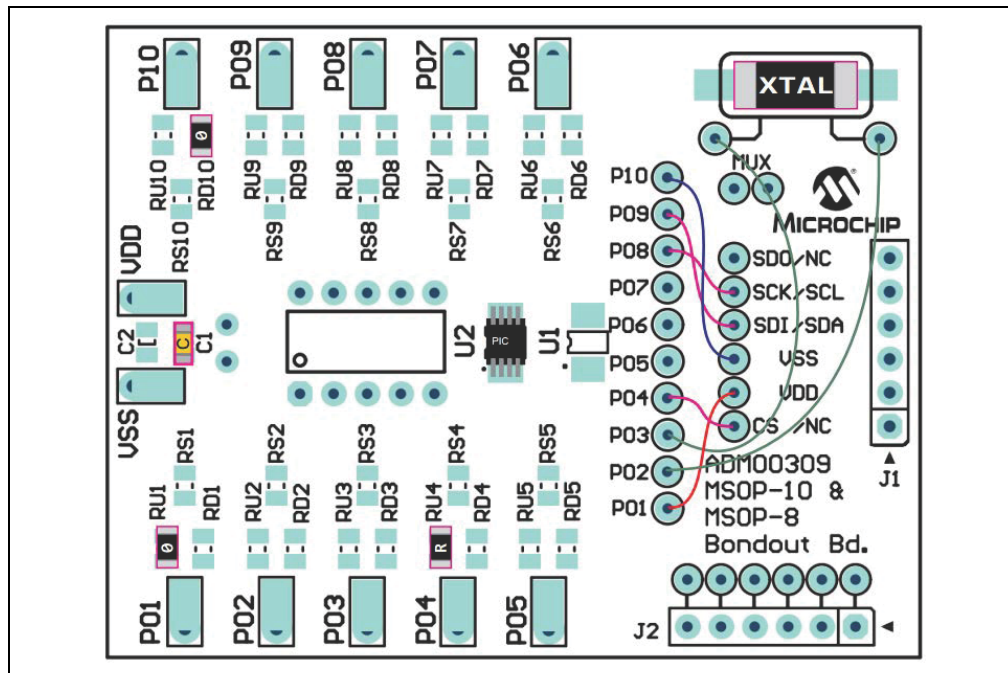


**FIGURE 2-14:** PIC12F1572 Pinout.

# 10-Pin MSOP and 8-Pin MSOP Evaluation Board User's Guide



**FIGURE 2-15:** PIC12F1572 ICP Header Example Connections Bottom View.



**FIGURE 2-16:** PIC12F1572 ICP Header Example Connections Top View.

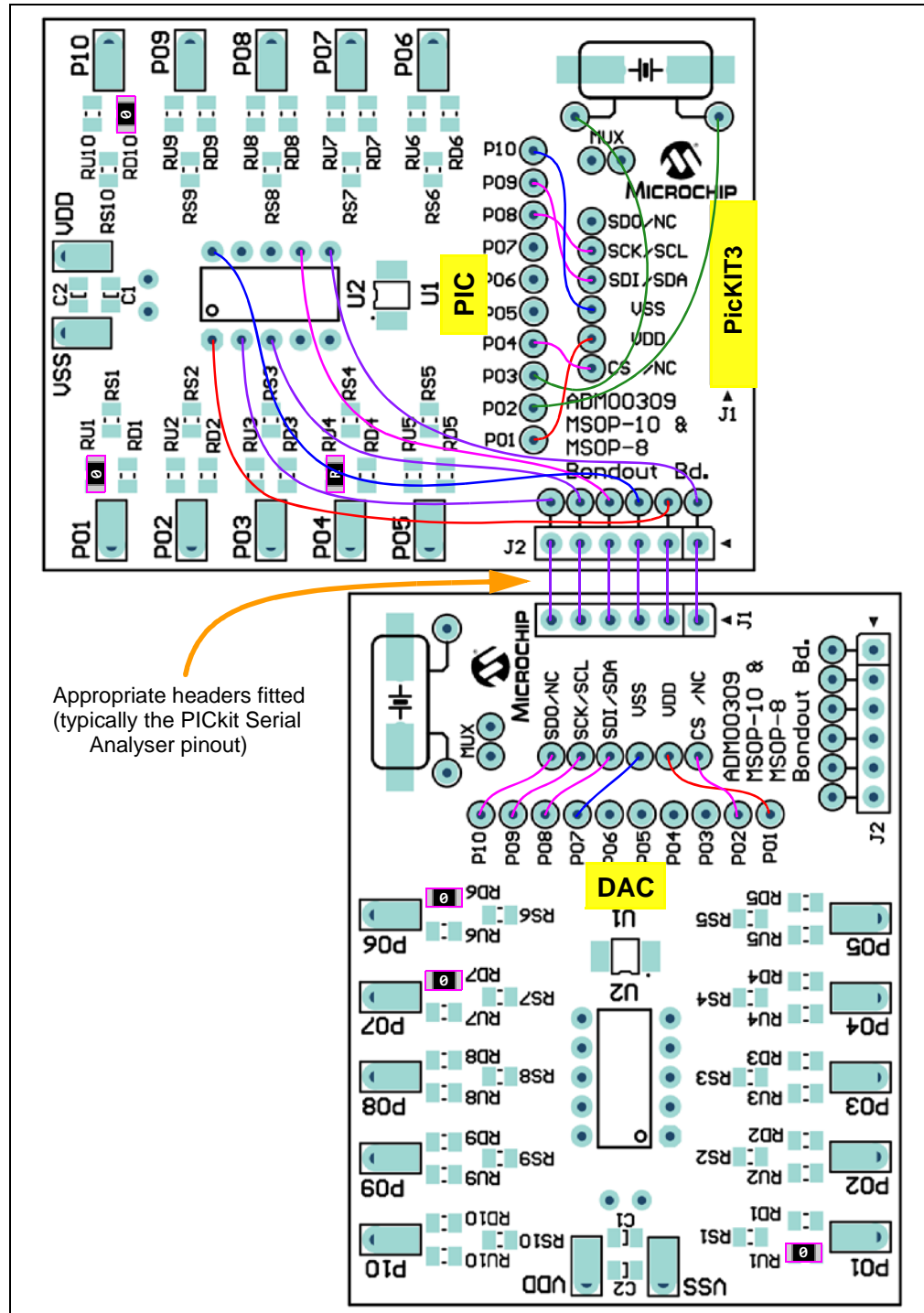
Other nanowatt XLP PIC Microcontrollers that are supported by this evaluation board are shown in [Table 2-7](#).

**TABLE 2-7: SUPPORTED MSOP-8 PIC MICROCONTROLLERS**

Device	Family/Core	Comments
PIC12F508	Baseline 8-bit	
PIC12F509	Baseline 8-bit	
PIC12F510	Baseline 8-bit	
PIC12F609	Mid-Range 8-bit	
PIC12F615	Mid-Range 8-bit	
PIC12F1501	Enhanced Mid-Range	
PIC12F1571	Enhanced Mid-Range	
PIC12F1572	Enhanced Mid-Range	
PIC12F617	Mid-Range 8-bit	
PIC12F519	Baseline 8-bit	
PIC12LF1552	Mid-Range 8-bit	

## 2.7 CREATING A SYSTEM WITH A PIC12F1572 MICROCONTROLLER AND A MCP48FEB22 DAC

The following image illustrates how to connect two ADM00309 boards in order to obtain a functional system. One board hosts a PIC12Fxxxx, which is programmed using a PicKIT3 connected to J1, and controls a second board, which has a MCP48FEB22-E/UN device installed. The J2 connector of the PIC board is used as a serial communication port, being connected to J1 of the DAC board.



**FIGURE 2-17:** Creating a Two-Board Evaluation System.

NOTES:





---

---

## Appendix A. Schematic and Layouts

---

---

### A.1 INTRODUCTION

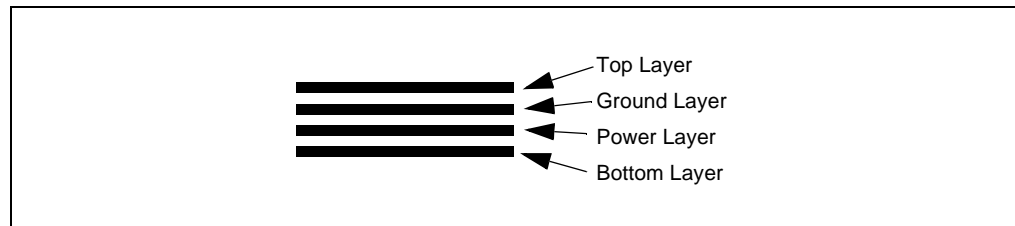
This appendix contains the following schematics and layouts for the 10-Pin MSOP and 8-Pin MSOP Evaluation Board:

- Board – Schematic
- Board – Top Silk Layer
- Board – Top Copper and Silk Layer
- Board – Top Copper
- Board – Bottom Copper Layer
- Board – Bottom Copper and Silk Layer

### A.2 SCHEMATICS AND PCB LAYOUT

**Section A.3 “Board – Schematic”** shows the schematic of the 10-Pin MSOP and 8-Pin MSOP Evaluation Board.

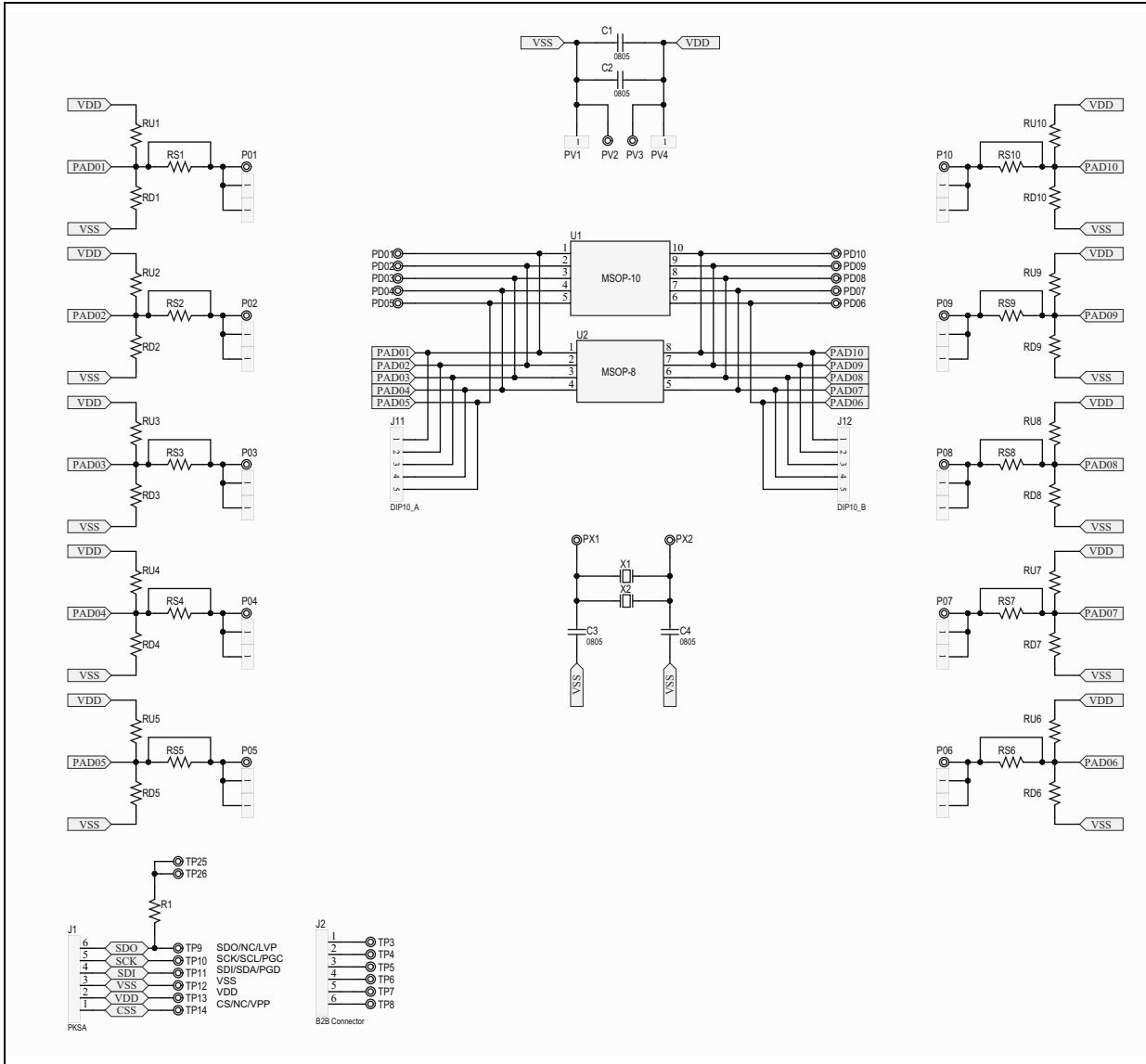
**Section A.4 “Board – Top Silk Layer”** shows the layout for the top layer of the 10-Pin MSOP and 8-Pin MSOP Evaluation Board. The layer order is shown in Figure A-1.



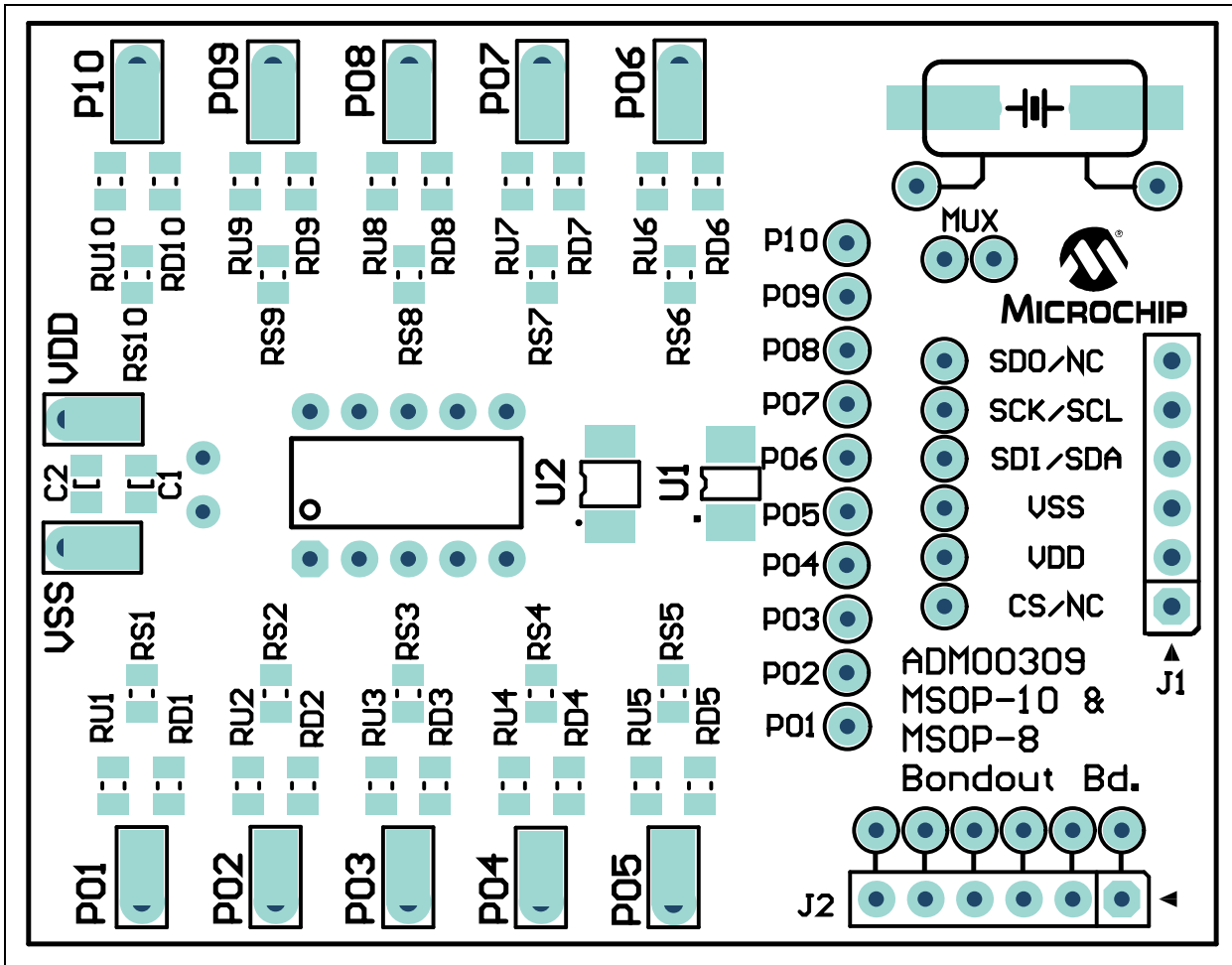
**FIGURE A-1:** *Layer Order.*

# 10-Pin MSOP and 8-Pin MSOP Evaluation Board

## A.3 BOARD – SCHEMATIC

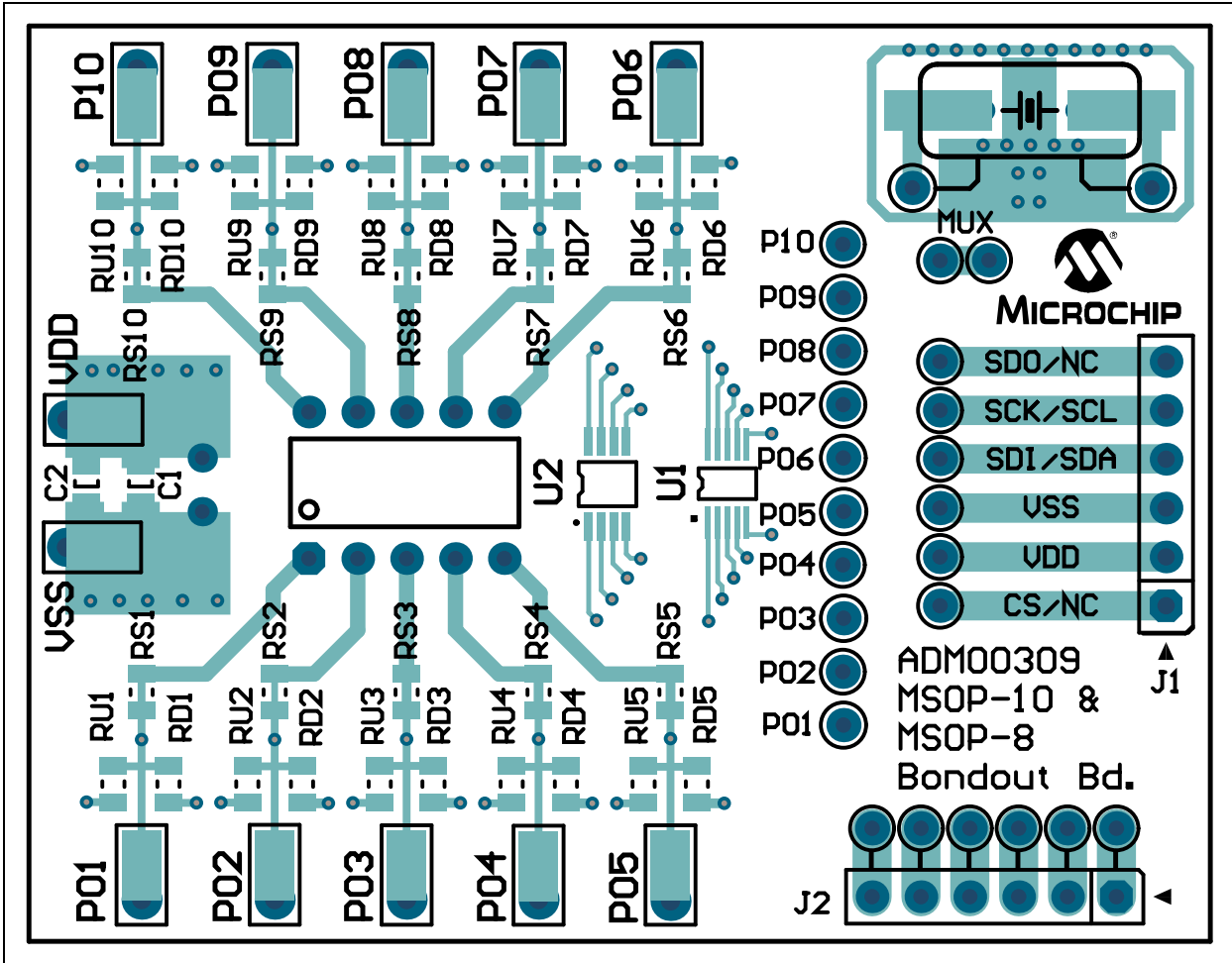


A.4 BOARD – TOP SILK LAYER

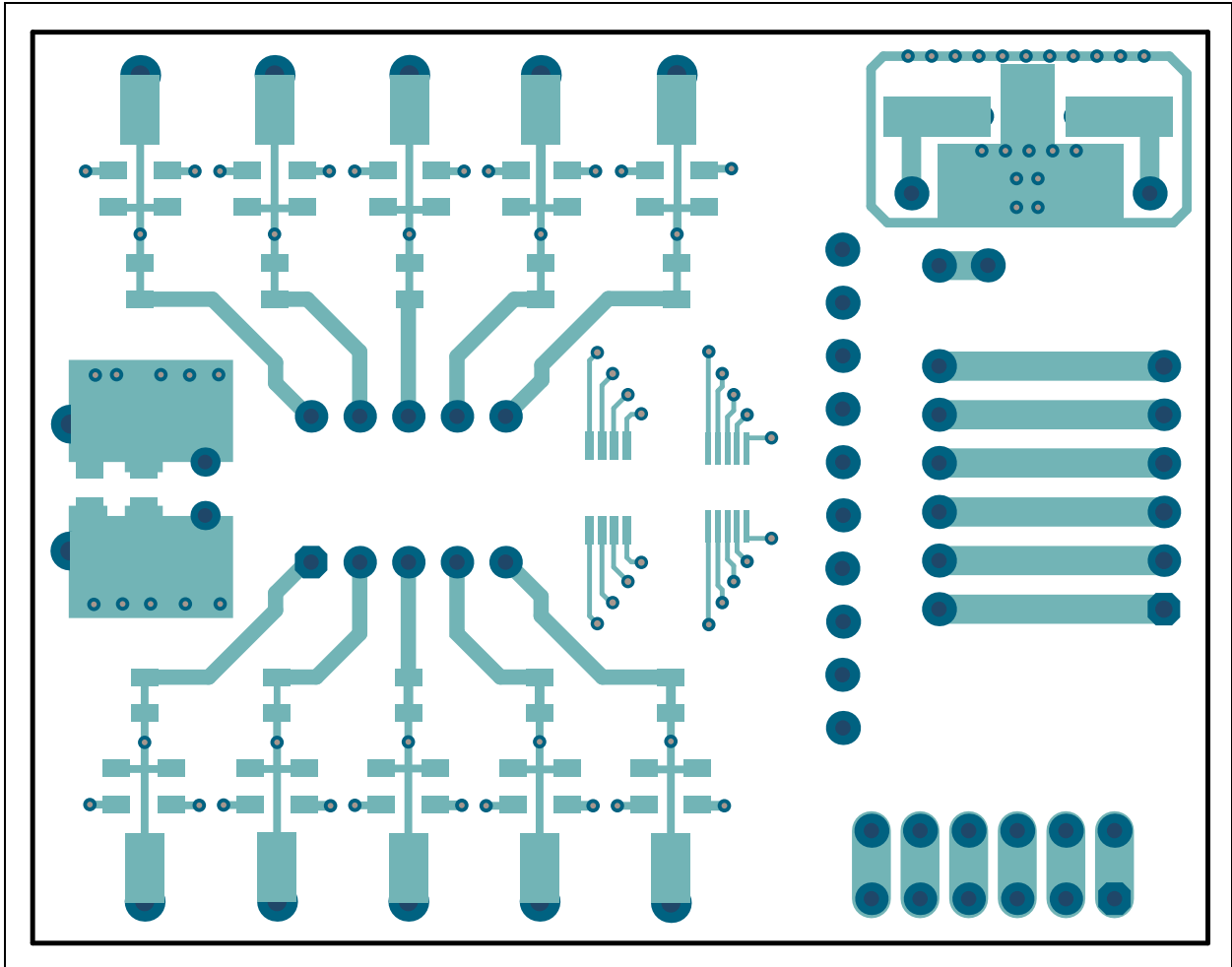


# 10-Pin MSOP and 8-Pin MSOP Evaluation Board

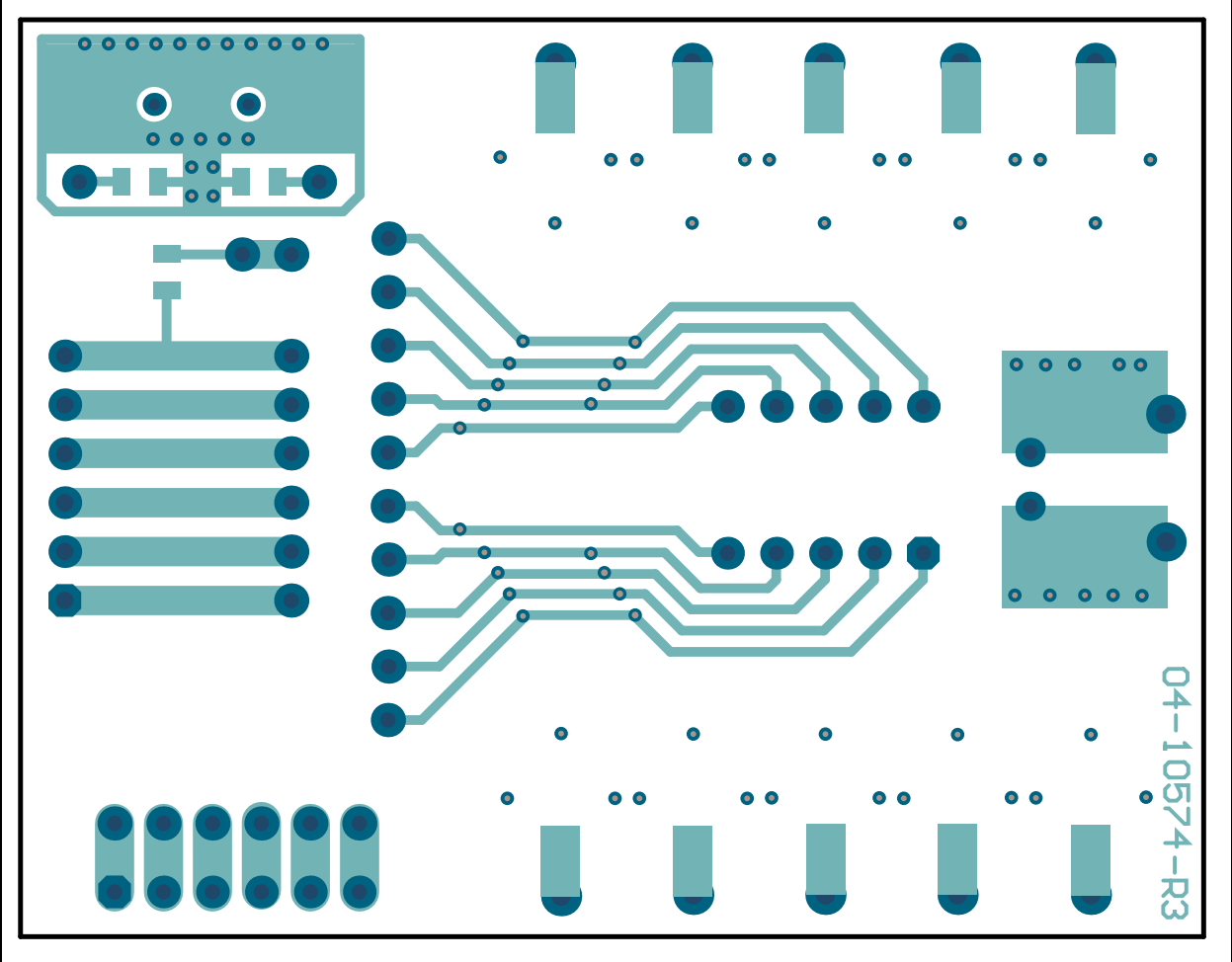
## A.5 BOARD – TOP COPPER AND SILK LAYER



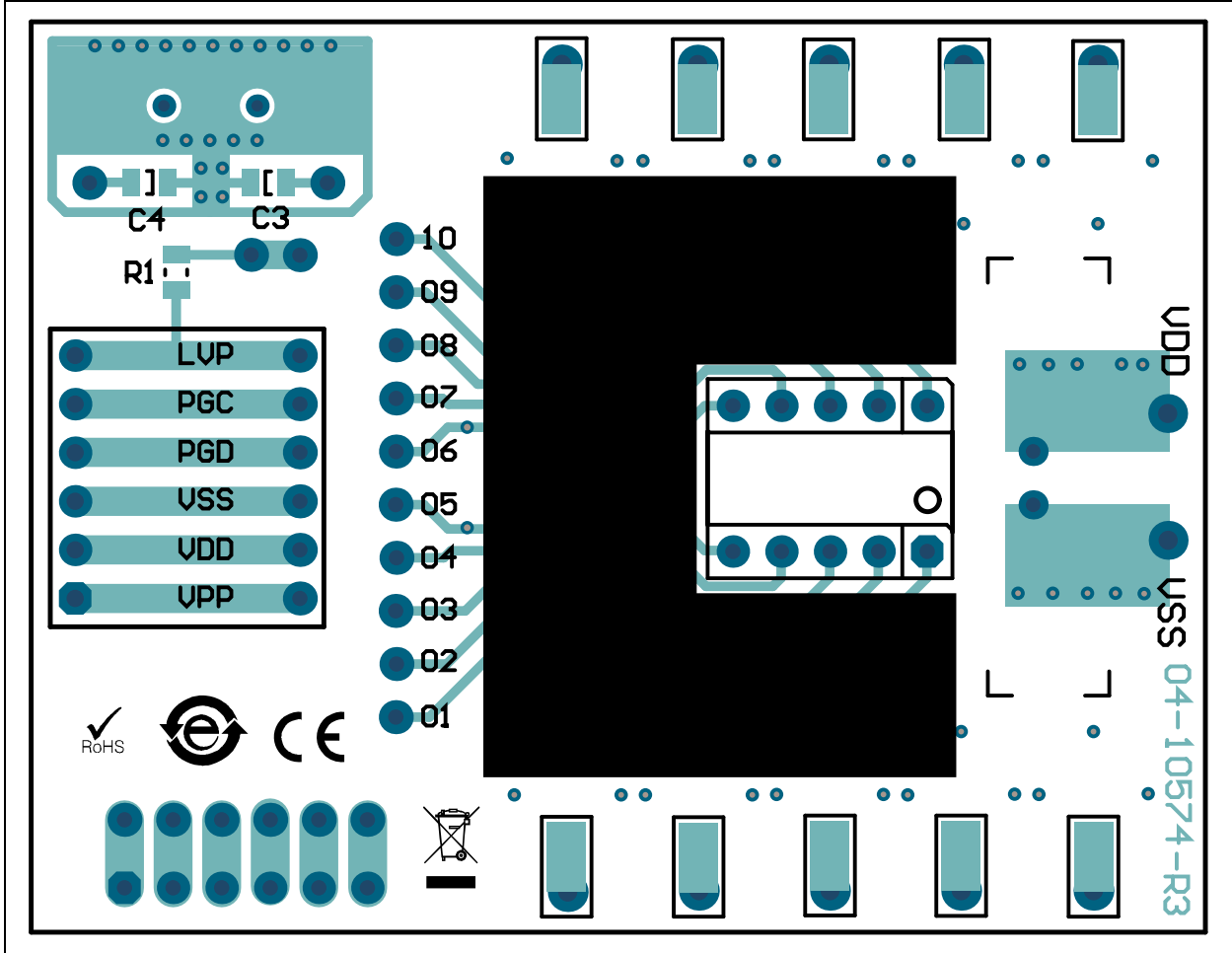
A.6 BOARD – TOP COPPER



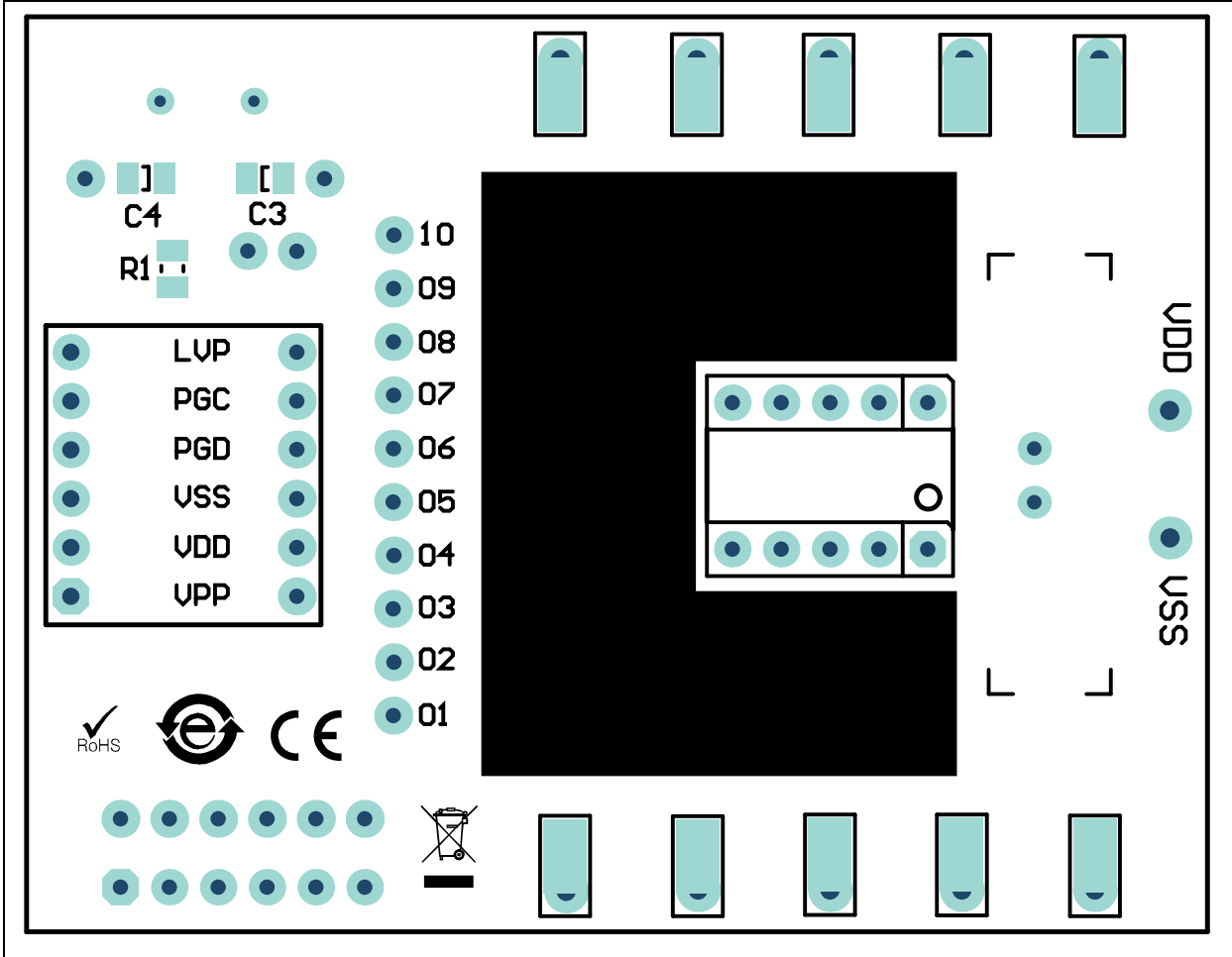
A.7 BOARD – BOTTOM COPPER LAYER



A.8 BOARD – BOTTOM COPPER AND SILK LAYER



A.9 BOARD – BOTTOM SILK LAYER







# MICROCHIP

## Worldwide Sales and Service

### AMERICAS

**Corporate Office**  
2355 West Chandler Blvd.  
Chandler, AZ 85224-6199  
Tel: 480-792-7200  
Fax: 480-792-7277  
Technical Support:  
<http://www.microchip.com/support>  
Web Address:  
[www.microchip.com](http://www.microchip.com)

**Atlanta**  
Duluth, GA  
Tel: 678-957-9614  
Fax: 678-957-1455

**Austin, TX**  
Tel: 512-257-3370

**Boston**  
Westborough, MA  
Tel: 774-760-0087  
Fax: 774-760-0088

**Chicago**  
Itasca, IL  
Tel: 630-285-0071  
Fax: 630-285-0075

**Dallas**  
Addison, TX  
Tel: 972-818-7423  
Fax: 972-818-2924

**Detroit**  
Novi, MI  
Tel: 248-848-4000

**Houston, TX**  
Tel: 281-894-5983

**Indianapolis**  
Noblesville, IN  
Tel: 317-773-8323  
Fax: 317-773-5453  
Tel: 317-536-2380

**Los Angeles**  
Mission Viejo, CA  
Tel: 949-462-9523  
Fax: 949-462-9608  
Tel: 951-273-7800

**Raleigh, NC**  
Tel: 919-844-7510

**New York, NY**  
Tel: 631-435-6000

**San Jose, CA**  
Tel: 408-735-9110  
Tel: 408-436-4270

**Canada - Toronto**  
Tel: 905-695-1980  
Fax: 905-695-2078

### ASIA/PACIFIC

**Asia Pacific Office**  
Suites 3707-14, 37th Floor  
Tower 6, The Gateway  
Harbour City, Kowloon

**Hong Kong**  
Tel: 852-2943-5100  
Fax: 852-2401-3431

**Australia - Sydney**  
Tel: 61-2-9868-6733  
Fax: 61-2-9868-6755

**China - Beijing**  
Tel: 86-10-8569-7000  
Fax: 86-10-8528-2104

**China - Chengdu**  
Tel: 86-28-8665-5511  
Fax: 86-28-8665-7889

**China - Chongqing**  
Tel: 86-23-8980-9588  
Fax: 86-23-8980-9500

**China - Dongguan**  
Tel: 86-769-8702-9880

**China - Guangzhou**  
Tel: 86-20-8755-8029

**China - Hangzhou**  
Tel: 86-571-8792-8115  
Fax: 86-571-8792-8116

**China - Hong Kong SAR**  
Tel: 852-2943-5100  
Fax: 852-2401-3431

**China - Nanjing**  
Tel: 86-25-8473-2460  
Fax: 86-25-8473-2470

**China - Qingdao**  
Tel: 86-532-8502-7355  
Fax: 86-532-8502-7205

**China - Shanghai**  
Tel: 86-21-3326-8000  
Fax: 86-21-3326-8021

**China - Shenyang**  
Tel: 86-24-2334-2829  
Fax: 86-24-2334-2393

**China - Shenzhen**  
Tel: 86-755-8864-2200  
Fax: 86-755-8203-1760

**China - Wuhan**  
Tel: 86-27-5980-5300  
Fax: 86-27-5980-5118

**China - Xian**  
Tel: 86-29-8833-7252  
Fax: 86-29-8833-7256

### ASIA/PACIFIC

**China - Xiamen**  
Tel: 86-592-2388138  
Fax: 86-592-2388130

**China - Zhuhai**  
Tel: 86-756-3210040  
Fax: 86-756-3210049

**India - Bangalore**  
Tel: 91-80-3090-4444  
Fax: 91-80-3090-4123

**India - New Delhi**  
Tel: 91-11-4160-8631  
Fax: 91-11-4160-8632

**India - Pune**  
Tel: 91-20-3019-1500

**Japan - Osaka**  
Tel: 81-6-6152-7160  
Fax: 81-6-6152-9310

**Japan - Tokyo**  
Tel: 81-3-6880-3770  
Fax: 81-3-6880-3771

**Korea - Daegu**  
Tel: 82-53-744-4301  
Fax: 82-53-744-4302

**Korea - Seoul**  
Tel: 82-2-554-7200  
Fax: 82-2-558-5932 or  
82-2-558-5934

**Malaysia - Kuala Lumpur**  
Tel: 60-3-6201-9857  
Fax: 60-3-6201-9859

**Malaysia - Penang**  
Tel: 60-4-227-8870  
Fax: 60-4-227-4068

**Philippines - Manila**  
Tel: 63-2-634-9065  
Fax: 63-2-634-9069

**Singapore**  
Tel: 65-6334-8870  
Fax: 65-6334-8850

**Taiwan - Hsin Chu**  
Tel: 886-3-5778-366  
Fax: 886-3-5770-955

**Taiwan - Kaohsiung**  
Tel: 886-7-213-7830

**Taiwan - Taipei**  
Tel: 886-2-2508-8600  
Fax: 886-2-2508-0102

**Thailand - Bangkok**  
Tel: 66-2-694-1351  
Fax: 66-2-694-1350

### EUROPE

**Austria - Wels**  
Tel: 43-7242-2244-39  
Fax: 43-7242-2244-393

**Denmark - Copenhagen**  
Tel: 45-4450-2828  
Fax: 45-4485-2829

**Finland - Espoo**  
Tel: 358-9-4520-820

**France - Paris**  
Tel: 33-1-69-53-63-20  
Fax: 33-1-69-30-90-79

**France - Saint Cloud**  
Tel: 33-1-30-60-70-00

**Germany - Garching**  
Tel: 49-8931-9700

**Germany - Haan**  
Tel: 49-2129-3766400

**Germany - Heilbronn**  
Tel: 49-7131-67-3636

**Germany - Karlsruhe**  
Tel: 49-721-625370

**Germany - Munich**  
Tel: 49-89-627-144-0  
Fax: 49-89-627-144-44

**Germany - Rosenheim**  
Tel: 49-8031-354-560

**Israel - Ra'anana**  
Tel: 972-9-744-7705

**Italy - Milan**  
Tel: 39-0331-742611  
Fax: 39-0331-466781

**Italy - Padova**  
Tel: 39-049-7625286

**Netherlands - Drunen**  
Tel: 31-416-690399  
Fax: 31-416-690340

**Norway - Trondheim**  
Tel: 47-7289-7561

**Poland - Warsaw**  
Tel: 48-22-3325737

**Romania - Bucharest**  
Tel: 40-21-407-87-50

**Spain - Madrid**  
Tel: 34-91-708-08-90  
Fax: 34-91-708-08-91

**Sweden - Gothenberg**  
Tel: 46-31-704-60-40

**Sweden - Stockholm**  
Tel: 46-8-5090-4654

**UK - Wokingham**  
Tel: 44-118-921-5800  
Fax: 44-118-921-5820

# Mouser Electronics

Authorized Distributor

Click to View Pricing, Inventory, Delivery & Lifecycle Information:

[Microchip:](#)

[ADM00309](#)