



High-Performance, Single-Ended, Current-Mode PWM Controllers

MAX5070/MAX5071

General Description

The MAX5070/MAX5071 BiCMOS, high-performance, current-mode PWM controllers have all the features required for wide input voltage range isolated/nonisolated power supplies. These controllers are used for low- and high-power universal input voltage and telecom power supplies.

The MAX5070/MAX5071 contain a fast comparator with only 60ns typical delay from current sense to the output for overcurrent protection. The MAX5070A/MAX5070B have an integrated error amplifier with the output at COMP. Soft-start is achieved by controlling the COMP voltage rise using external components.

The frequency is adjustable from 20kHz to 1MHz with an external resistor and capacitor. The timing capacitor discharge current is trimmed allowing for programmable dead time and maximum duty cycle for a given frequency. The available saw-toothed waveform at RT/CT can be used for slope compensation when needed.

The MAX5071A/MAX5071B include a bidirectional synchronization circuit allowing for multiple controllers to run at the same frequency to avoid beat frequencies. Synchronization is accomplished by simply connecting the SYNC pins of all devices together. When synchronizing with other devices, the MAX5071A/MAX5071B with the highest frequency synchronizes the other devices. Alternatively, the MAX5071A/MAX5071B can be synchronized to an external clock with an open-drain output stage running at a higher frequency.

The MAX5071C provides a clock output pulse (ADV_CLK) that leads the driver output (OUT) by 110ns. The advanced clock signal is used to drive the secondary-side synchronous rectifiers.

The MAX5070/MAX5071 are available in 8-pin μ MAX[®] and SO packages and operate over the automotive temperature range of -40°C to +125°C.

Applications

- Universal Input AC/DC Power Supplies
- Isolated Telecom Power Supplies
- Isolated Power-Supply Modules
- Networking Systems
- Computer Systems/Servers
- Industrial Power Conversion
- Isolated Keep-Alive Circuits

μ MAX is a registered trademark of Maxim Integrated Products, Inc.



Features

- ◆ Pin-for-Pin Replacement for UC2842 (MAX5070A) and UC2844 (MAX5070B)
- ◆ 2A Drive Source and 1A Sink Capability
- ◆ Up to 1MHz Switching Frequency Operation
- ◆ Bidirectional Synchronization (MAX5071A/MAX5071B)
- ◆ Advanced Output Drive for Secondary-Side Synchronous Rectification (MAX5071C)
- ◆ Fast 60ns Cycle-by-Cycle Current Limit
- ◆ Trimmed Oscillator Capacitor Discharge Current Sets Maximum Duty Cycle Accurately
- ◆ Accurate 5% Start and Stop Voltage with 6V Hysteresis
- ◆ Low 32 μ A Startup Current
- ◆ 5V Regulator Output (VREF) with 20mA Capability
- ◆ Overtemperature Shutdown

Ordering Information

PART	TEMP RANGE	PIN-PACKAGE
MAX5070AASA	-40°C to +125°C	8 SO
MAX5070AAUA	-40°C to +125°C	8 μ MAX
MAX5070BASA	-40°C to +125°C	8 SO
MAX5070BAUA	-40°C to +125°C	8 μ MAX

Specify lead-free by adding the + symbol at the end of the part number when ordering.

Ordering Information continued at end of data sheet.

Selector Guide appears at end of data sheet.

Pin Configurations

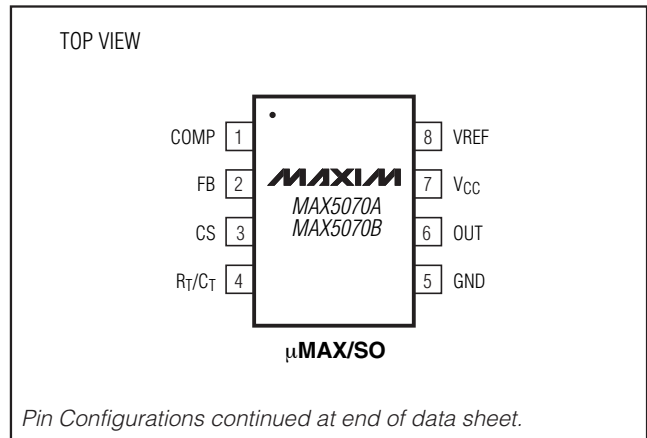

High-Performance, Single-Ended, Current-Mode PWM Controllers

ABSOLUTE MAXIMUM RATINGS

V_{CC} (Low-Impedance Source) to GND-0.3V to +30V
 V_{CC} (I_{CC} < 30mA).....Self Limiting
 OUT to GND-0.3V to (V_{CC} + 0.3V)
 OUT Current.....±1A for 10μs
 FB, SYNC, COMP, CS, R_T/C_T, VREF to GND-0.3V to +6V
 COMP Sink Current (MAX5070).....10mA

Continuous Power Dissipation (T_A = +70°C)
 8-Pin μMAX (derate 4.5mW/°C above +70°C)362mW
 8-Pin SO (derate 5.9mW/°C above +70°C).....470.6mW
 Operating Temperature Range (Automotive)-40°C to +125°C
 Maximum Junction Temperature+150°C
 Storage Temperature Range-65°C to +150°C
 Lead Temperature (soldering, 10s)+300°C

Stresses beyond those listed under "Absolute Maximum Ratings" may cause permanent damage to the device. These are stress ratings only, and functional operation of the device at these or any other conditions beyond those indicated in the operational sections of the specifications is not implied. Exposure to absolute maximum rating conditions for extended periods may affect device reliability.

ELECTRICAL CHARACTERISTICS

(V_{CC} = +15V, R_T = 10kΩ, C_T = 3.3nF, V_{VREF} = OPEN, C_{VREF} = 0.1μF, COMP = OPEN, V_{FB} = 2V, CS = GND, T_A = -40°C to +85°C, unless otherwise noted.) (Note 1)

PARAMETER	SYMBOL	CONDITIONS	MIN	TYP	MAX	UNITS
REFERENCE						
Output Voltage	V _{VREF}	T _A = +25°C, I _{VREF} = 1mA	4.950	5.000	5.050	V
Line Regulation	ΔV _{LINE}	12V < V _{CC} < 25V, I _{VREF} = 1mA		0.4	4	mV
Load Regulation	ΔV _{LOAD}	1mA < I _{VREF} < 20mA		6	25	mV
Total Output Variation	V _{REFT}	1mA < I _{VREF} < 20mA, 12V < V _{CC} < 25V	4.9		5.1	V
Reference Output-Noise Voltage	V _{NOISE}	10Hz < f < 10kHz, T _A = +25°C		50		μV
Reference Output Short Circuit	I _{S_SC}	V _{VREF} = 0V	-30	-100	-180	mA
OSCILLATOR						
Initial Accuracy		T _A = +25°C	51	54	57	kHz
Voltage Stability		12V < V _{CC} < 25V		0.2	0.5	%
Temp Stability		-40°C < T _A < +85°C		0.5		%
R _T /C _T Voltage Ramp (P-P)	V _{RAMP}			1.7		V
R _T /C _T Voltage Ramp Valley	V _{RAMP_VALLEY}			1.1		V
Discharge Current	I _{DIS}	V _{RT/CT} = 2V, T _A = +25°C	7.9	8.3	8.7	mA
Frequency Range	f _{OSC}		20		1000	kHz
ERROR AMPLIFIER (MAX5070A/MAX5070B)						
FB Input Voltage	V _{FB}	FB shorted to COMP	2.465	2.5	2.535	V
FB Input Bias Current	I _{B(FB)}			-0.01	-0.1	μA
Open-Loop Voltage Gain	A _{VOL}	2V ≤ V _{COMP} ≤ 4V		100		dB
Unity-Gain Bandwidth	f _{GBW}			1		MHz
Power-Supply Rejection Ratio	PSRR	12V ≤ V _{CC} ≤ 25V (Note 2)	60	80		dB
COMP Sink Current	I _{SINK}	V _{FB} = 2.7V, V _{COMP} = 1.1V	2	6		mA
COMP Source Current	I _{SOURCE}	V _{FB} = 2.3V, V _{COMP} = 5V	-0.5	-1.2	-1.8	mA
COMP Output High Voltage	V _{COMP_H}	V _{FB} = 2.3V, R _{COMP} = 15kΩ to GND	5	5.8		V
COMP Output Low Voltage	V _{COMP_L}	V _{FB} = 2.7V, R _{COMP} = 15kΩ to VREF		0.1	0.5	V
CURRENT-SENSE AMPLIFIER						
Gain	A _{CS}	(Notes 3, 4)	2.85	3	3.26	V/V
Maximum Current-Sense Signal	V _{CS_MAX}	MAX5070A/B (Note 3)	0.95	1	1.05	V
		V _{COMP} = 5V, MAX5071_	0.95	1	1.05	

High-Performance, Single-Ended, Current-Mode PWM Controllers

MAX5070/MAX5071

ELECTRICAL CHARACTERISTICS (continued)

(V_{CC} = +15V, R_T = 10kΩ, C_T = 3.3nF, V_{VREF} = OPEN, C_{VREF} = 0.1μF, COMP = OPEN, V_{FB} = 2V, CS = GND, T_A = -40°C to +85°C, unless otherwise noted.) (Note 1)

PARAMETER	SYMBOL	CONDITIONS	MIN	TYP	MAX	UNITS
Power-Supply Rejection Ratio	PSRR	12V ≤ V _{CC} ≤ 25V		70		dB
Input Bias Current	I _{CS}	V _{COMP} = 0V		-1	-2.5	μA
Delay From CS to OUT	t _{CS_DELAY}	50mV overdrive		60		ns
MOSFET DRIVER						
OUT Low-Side On-Resistance	V _{RDS_ONL}	I _{SINK} = 200mA		4.5	10	Ω
OUT High-Side On-Resistance	V _{RDS_ONH}	I _{SOURCE} = 100mA		3.5	7	Ω
I _{SOURCE} (Peak)	I _{SOURCE}	C _{OUT} = 10nF		2		A
I _{SINK} (Peak)	I _{SINK}	C _{OUT} = 10nF		1		A
Rise Time	t _r	C _{OUT} = 1nF		15		ns
Fall Time	t _f	C _{OUT} = 1nF		22		ns
UNDERVOLTAGE LOCKOUT/STARTUP						
Startup Voltage Threshold	V _{CC_START}		15.2	16	16.8	V
Minimum Operating Voltage After Turn-On	V _{CC_MIN}		9.2	10	10.8	V
Undervoltage-Lockout Hysteresis	UVLOHYST			6		V
PWM						
Maximum Duty Cycle	D _{MAX}	MAX5070A/MAX5071A	94.5	96	97.5	%
		MAX5070B/MAX5071B/MAX5071C	48	49.8	50	
Minimum Duty Cycle	D _{MIN}			0		%
SUPPLY CURRENT						
Startup Supply Current	I _{START}			32	65	μA
Operating Supply Current	I _{CC}	V _{FB} = V _{CS} = 0V		3	5	mA
Zener Bias Voltage at V _{CC}	V _Z	I _{CC} = 25mA	24	26.5		V
THERMAL SHUTDOWN						
Thermal Shutdown	T _{SHDN}			+150		°C
Thermal-Shutdown Hysteresis	T _{HYST}			4		°C
SYNCHRONIZATION (MAX5071A/MAX5071B only) (Note 5)						
SYNC Frequency Range	f _{SYNC}		20		1000	kHz
SYNC Clock Input High Threshold	V _{SYNCINH}		3.5			V
SYNC Clock Input Low Threshold	V _{SYNCINL}				0.8	V
SYNC Clock Input Minimum Pulse Width	t _{PW_SYNCIN}		200			ns
SYNC Clock Output High Level	V _{SYNCOH}	1mA external pulldown	4.0	4.7		V
SYNC Clock Output Low Level	V _{SYNCOL}	R _{SYNC} = 5kΩ		0	0.1	V
SYNC Leakage Current	I _{SYNC}	V _{SYNC} = 0V		0.01	0.1	μA

High-Performance, Single-Ended, Current-Mode PWM Controllers

ELECTRICAL CHARACTERISTICS (continued)

($V_{CC} = +15V$, $R_T = 10k\Omega$, $C_T = 3.3nF$, $V_{VREF} = OPEN$, $C_{VREF} = 0.1\mu F$, $COMP = OPEN$, $V_{FB} = 2V$, $CS = GND$, $T_A = -40^\circ C$ to $+85^\circ C$, unless otherwise noted.) (Note 1)

PARAMETER	SYMBOL	CONDITIONS	MIN	TYP	MAX	UNITS
ADV_CLK (MAX5071C only)						
ADV_CLK High Voltage	V_{ADV_CLKH}	$I_{ADV_CLK} = 10mA$ source	2.4	3		V
ADV_CLK Low Voltage	V_{ADV_CLKL}	$I_{ADV_CLK} = 10mA$ sink			0.4	V
ADV_CLK Output Pulse Width	t_{PULSE}			85		ns
ADV_CLK Rising Edge to OUT Rising Edge	t_{ADV_CLK}			110		ns
ADV_CLK Source and Sink Current	I_{ADV_CLK}		10			mA

ELECTRICAL CHARACTERISTICS

($V_{CC} = +15V$, $R_T = 10k\Omega$, $C_T = 3.3nF$, $V_{VREF} = OPEN$, $C_{VREF} = 0.1\mu F$, $COMP = OPEN$, $V_{FB} = 2V$, $CS = GND$, $T_A = -40^\circ C$ to $+125^\circ C$, unless otherwise noted.) (Note 1)

PARAMETER	SYMBOL	CONDITIONS	MIN	TYP	MAX	UNITS
REFERENCE						
Output Voltage	V_{VREF}	$T_A = +25^\circ C$, $I_{VREF} = 1mA$	4.950	5.000	5.050	V
Line Regulation	ΔV_{LINE}	$12V < V_{CC} < 25V$, $I_{VREF} = 1mA$		0.4	4	mV
Load Regulation	ΔV_{LOAD}	$1mA < I_{VREF} < 20mA$		6	25	mV
Total Output Variation	V_{REFT}	$1mA < I_{VREF} < 20mA$, $12V < V_{CC} < 25V$	4.9		5.1	V
Reference Output Noise Voltage	V_{NOISE}	$10Hz < f < 10kHz$, $T_A = +25^\circ C$		50		μV
Reference Output Short Circuit	I_{S_SC}	$V_{VREF} = 0V$	-30	-100	-180	mA
OSCILLATOR						
Initial Accuracy		$T_A = +25^\circ C$	51	54	57	kHz
Voltage Stability		$12V < V_{CC} < 25V$		0.2	0.5	%
Temp Stability		$-40^\circ C < T_A < +125^\circ C$		1		%
R_T/C_T Voltage Ramp (P-P)	V_{RAMP}			1.7		V
R_T/C_T Voltage Ramp Valley	V_{RAMP_VALLEY}			1.1		V
Discharge Current	I_{DIS}	$V_{RT/CT} = 2V$, $T_A = +25^\circ C$	7.9	8.3	8.7	mA
Frequency Range	f_{OSC}		20		1000	kHz
ERROR AMPLIFIER (MAX5070A/MAX5070B)						
FB Input Voltage	V_{FB}	FB shorted to COMP	2.465	2.5	2.535	V
FB Input Bias Current	$I_{B(FB)}$			-0.01	-0.1	μA
Open-Loop Voltage Gain	A_{VOL}	$2V \leq V_{COMP} \leq 4V$		100		dB
Unity-Gain Bandwidth	f_{GBW}			1		MHz
Power-Supply Rejection Ratio	PSRR	$12V \leq V_{CC} \leq 25V$ (Note 2)	60	80		dB
COMP Sink Current	I_{SINK}	$V_{FB} = 2.7V$, $V_{COMP} = 1.1V$	2	6		mA
COMP Source Current	I_{SOURCE}	$V_{FB} = 2.3V$, $V_{COMP} = 5V$	-0.5	-1.2	-1.8	mA
COMP Output High Voltage	V_{COMP_H}	$V_{FB} = 2.3V$, $R_{COMP} = 15k\Omega$ to GND	5	5.8		V
COMP Output Low Voltage	V_{COMP_L}	$V_{FB} = 2.7V$, $R_{COMP} = 15k\Omega$ to VREF		0.1	0.5	V

High-Performance, Single-Ended, Current-Mode PWM Controllers

MAX5070/MAX5071

ELECTRICAL CHARACTERISTICS (continued)

($V_{CC} = +15V$, $R_T = 10k\Omega$, $C_T = 3.3nF$, $V_{VREF} = OPEN$, $C_{VREF} = 0.1\mu F$, $COMP = OPEN$, $V_{FB} = 2V$, $CS = GND$, $T_A = -40^\circ C$ to $+125^\circ C$, unless otherwise noted.) (Note 1)

PARAMETER	SYMBOL	CONDITIONS	MIN	TYP	MAX	UNITS
CURRENT-SENSE AMPLIFIER						
Gain	ACS	(Notes 3, 4)	2.85	3	3.26	V/V
Maximum Current-Sense Signal	VCS_MAX	MAX5070A/B (Note 3)	0.95	1	1.05	V
		$V_{COMP} = 5V$, MAX5071_	0.95	1	1.05	
Power-Supply Rejection Ratio	PSRR	$12V \leq V_{CC} \leq 25V$		70		dB
Input Bias Current	I _{CS}			-1	-2.5	μA
Delay From CS to OUT	t _{CS_DELAY}	50mV overdrive		60		ns
MOSFET DRIVER						
OUT Low-Side On-Resistance	V _{RDS_ONL}	I _{SINK} = 200mA		4.5	12	Ω
OUT High-Side On-Resistance	V _{RDS_ONH}	I _{SOURCE} = 100mA		3.5	9	Ω
I _{SOURCE} (Peak)	I _{SOURCE}	C _{OUT} = 10nF		2		A
I _{SINK} (Peak)	I _{SINK}	C _{OUT} = 10nF		1		A
Rise Time	t _r	C _{OUT} = 1nF		15		ns
Fall Time	t _f	C _{OUT} = 1nF		22		ns
UNDERVOLTAGE LOCKOUT/STARTUP						
Startup Voltage Threshold	V _{CC_START}		15.2	16	16.8	V
Minimum Operating Voltage After Turn-On	V _{CC_MIN}		9.2	10	10.8	V
Undervoltage-Lockout Hysteresis	UVLO _{HYST}			6		V
PWM						
Maximum Duty Cycle	D _{MAX}	MAX5070A/MAX5071A	94.5	96	97.5	%
		MAX5070B/MAX5071B/MAX5071C	48	49.8	50	
Minimum Duty Cycle	D _{MIN}			0		%
SUPPLY CURRENT						
Startup Supply Current	I _{START}			32	65	μA
Operating Supply Current	I _{CC}	$V_{FB} = V_{CS} = 0V$		3	5	mA
Zener Bias Voltage at V _{CC}	V _Z	I _{CC} = 25mA	24	26.5		V
THERMAL SHUTDOWN						
Thermal Shutdown	T _{SHDN}			+150		$^\circ C$
Thermal-Shutdown Hysteresis	T _{HYST}			4		$^\circ C$
SYNCHRONIZATION (MAX5071A/MAX5071B only, Note 5)						
SYNC Frequency Range	f _{SYNC}		20		1000	kHz
SYNC Clock Input High Threshold	V _{SYNCINH}		3.5			V
SYNC Clock Input Low Threshold	V _{SYNCINL}				0.8	V
SYNC Clock Input Minimum Pulse Width	t _{PW_SYNCIN}		200			ns
SYNC Clock Output High Level	V _{SYNCOH}	1mA external pulldown	4.0	4.7		V
SYNC Clock Output Low Level	V _{SYNCOL}	R _{SYNC} = 5k Ω		0	0.1	V

High-Performance, Single-Ended, Current-Mode PWM Controllers

ELECTRICAL CHARACTERISTICS (continued)

($V_{CC} = +15V$, $R_T = 10k\Omega$, $C_T = 3.3nF$, $V_{VREF} = OPEN$, $C_{VREF} = 0.1\mu F$, $COMP = OPEN$, $V_{FB} = 2V$, $CS = GND$, $T_A = -40^\circ C$ to $+125^\circ C$, unless otherwise noted.) (Note 1)

PARAMETER	SYMBOL	CONDITIONS	MIN	TYP	MAX	UNITS
SYNC Leakage Current	I_{SYNC}	$V_{SYNC} = 0V$		0.01	0.1	μA
ADV_CLK (MAX5071C only)						
ADV_CLK High Voltage	V_{ADV_CLKH}	$I_{ADV_CLK} = 10mA$ source	2.4	3		V
ADV_CLK Low Voltage	V_{ADV_CLKL}	$I_{ADV_CLK} = 10mA$ sink			0.4	V
ADV_CLK Output Pulse Width	t_{PULSE}			85		ns
ADV_CLK Rising Edge to OUT Rising Edge	t_{ADV_CLK}			110		ns
ADV_CLK Source and Sink Current	I_{ADV_CLK}		10			mA

Note 1: All devices are 100% tested at $+25^\circ C$. All limits over temperature are guaranteed by design, not production tested.

Note 2: Guaranteed by design, not production tested.

Note 3: Parameter measured at trip point of latch with $V_{FB} = 0V$ (MAX5070A/MAX5070B only).

Note 4: Gain is defined as $A = \Delta V_{COMP} / \Delta V_{CS}$, $0 \leq V_{CS} \leq 0.8V$.

Note 5: Output Frequency equals oscillator frequency for MAX5070A/MAX5071A. Output frequency is one-half oscillator frequency for MAX5070B/MAX5071B/MAX5071C.

Typical Operating Characteristics

($V_{CC} = 15V$, $T_A = +25^\circ C$, unless otherwise noted.)

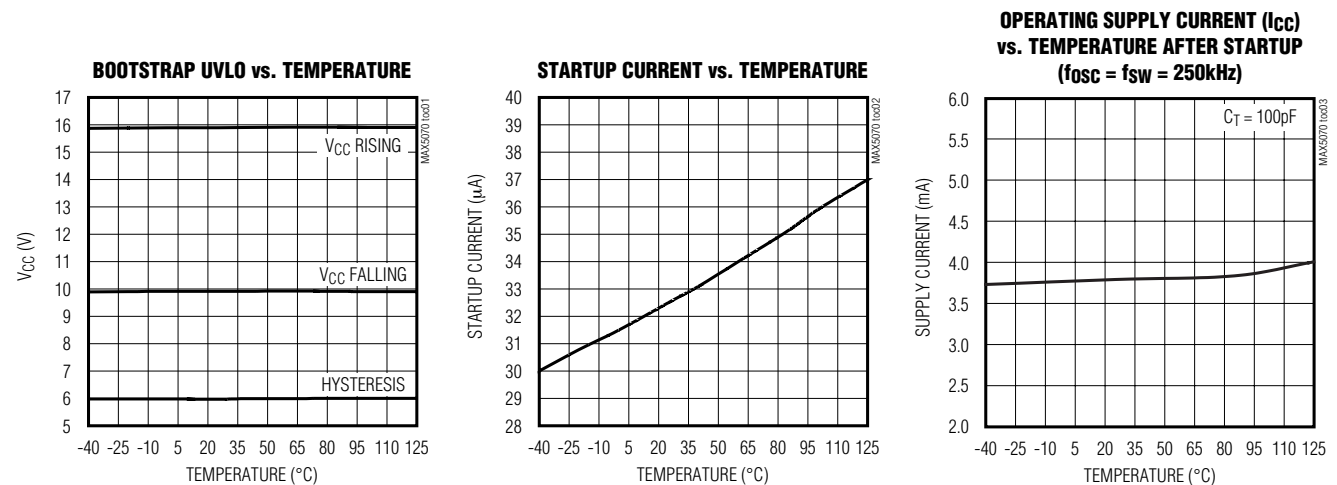

High-Performance, Single-Ended, Current-Mode PWM Controllers

MAX5070/MAX5071

Typical Operating Characteristics (continued)

($V_{CC} = 15V$, $T_A = +25^\circ C$, unless otherwise noted.)

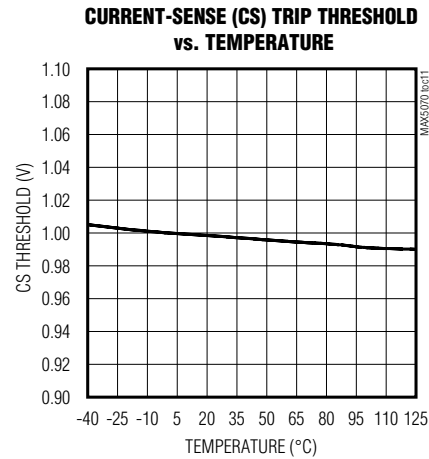
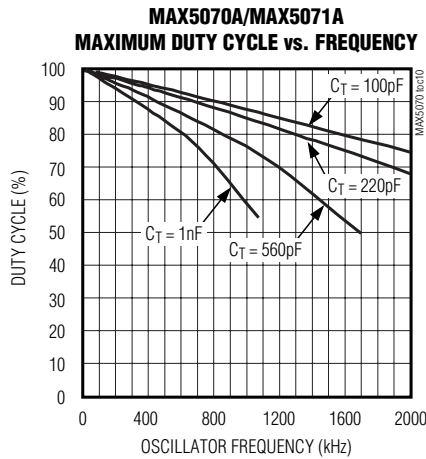
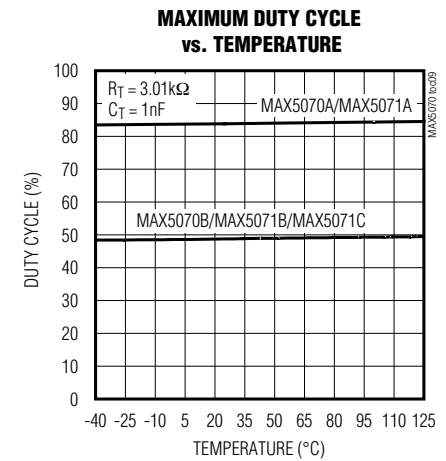
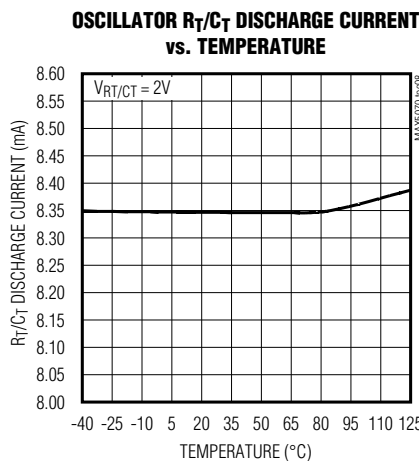
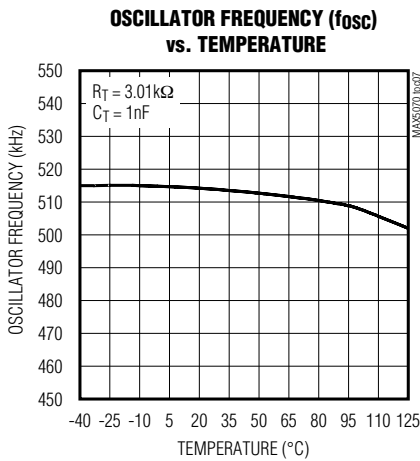
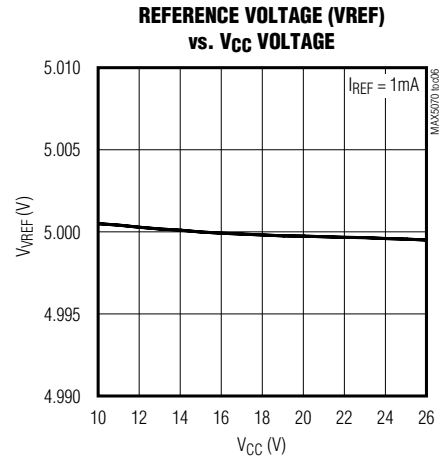
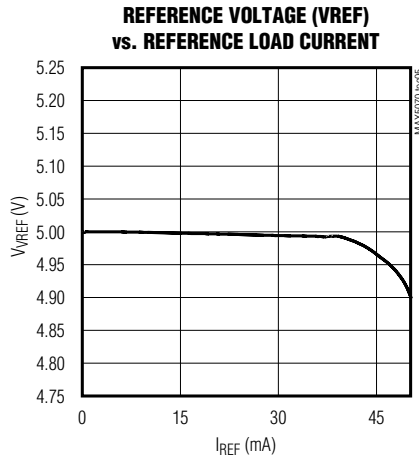
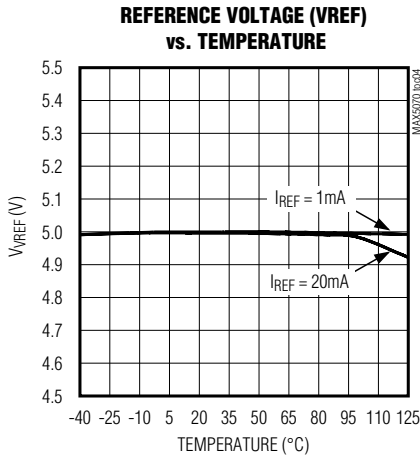

High-Performance, Single-Ended, Current-Mode PWM Controllers

Typical Operating Characteristics (continued)

($V_{CC} = 15V$, $T_A = +25^\circ C$, unless otherwise noted.)

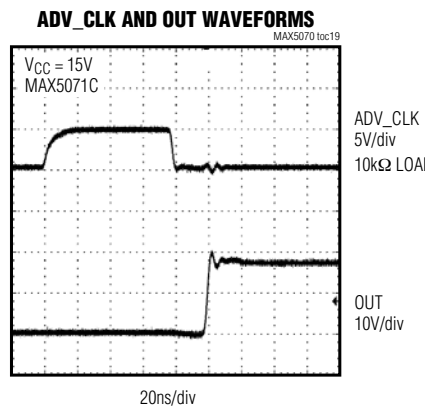
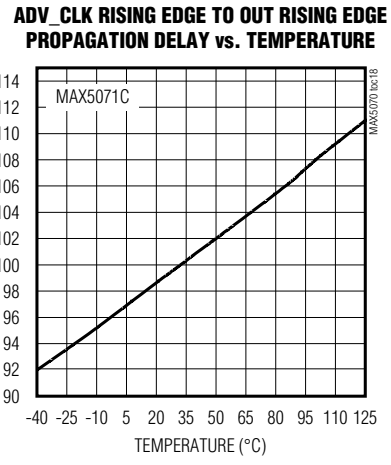
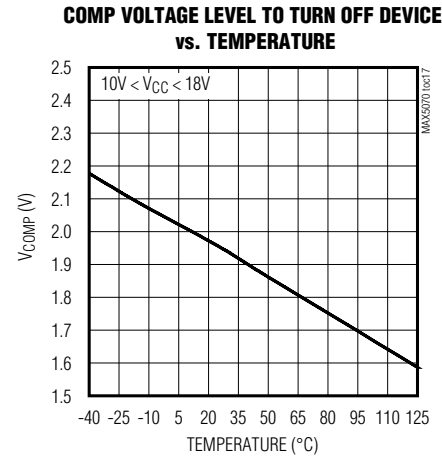
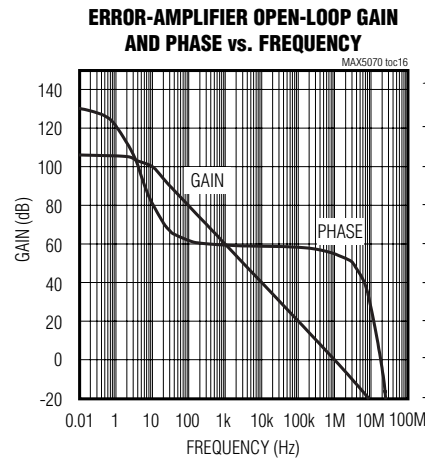
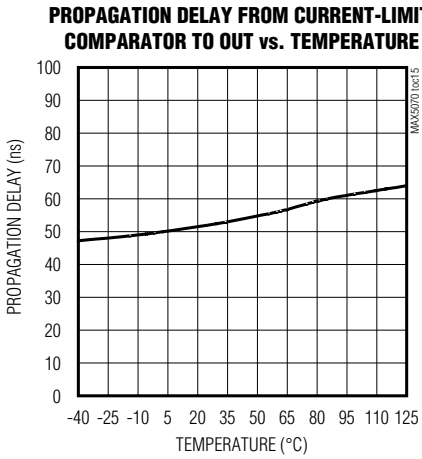
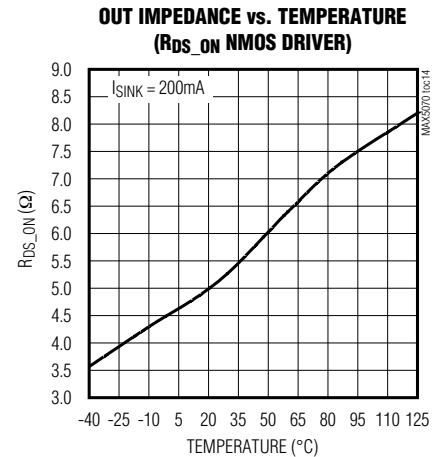
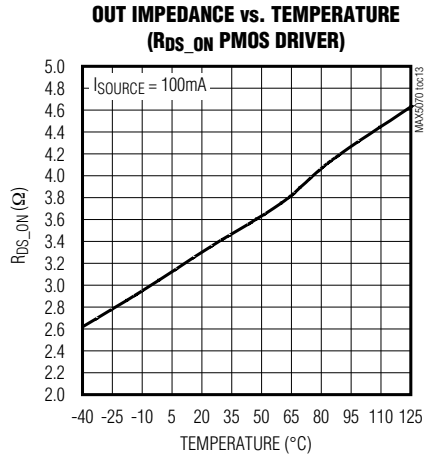
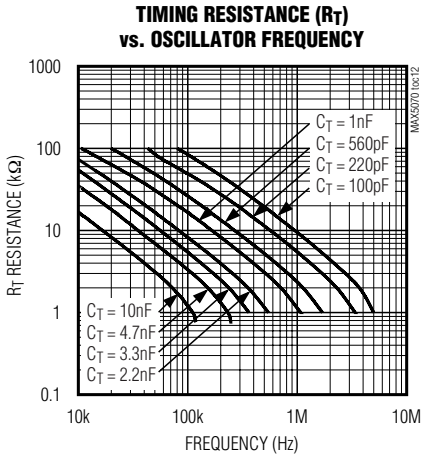

High-Performance, Single-Ended, Current-Mode PWM Controllers

Typical Operating Characteristics (continued)

($V_{CC} = 15V$, $T_A = +25^\circ C$, unless otherwise noted.)

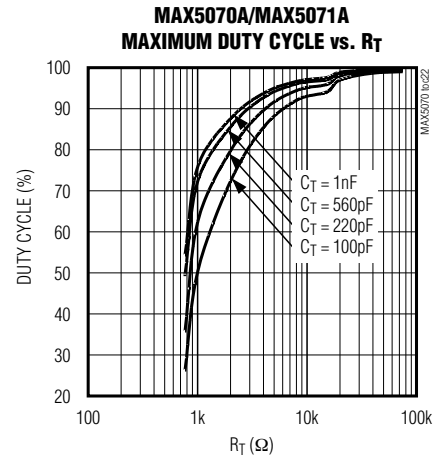
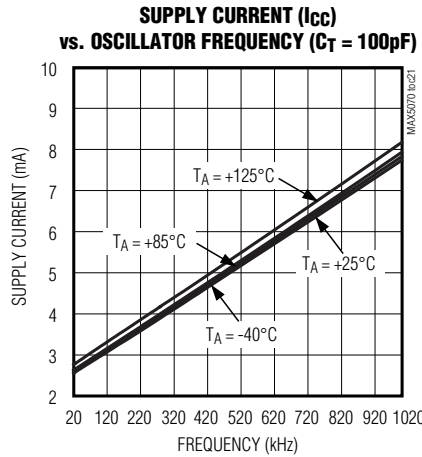
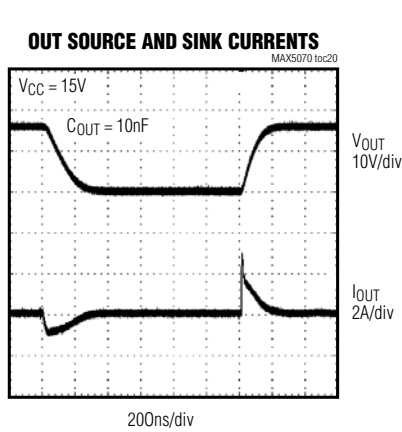

MAX5070/MAX5071

Pin Descriptions

MAX5070A/MAX5070B

PIN	NAME	FUNCTION
1	COMP	Error-Amplifier Output. COMP can be used for soft-start.
2	FB	Error-Amplifier Inverting Input
3	CS	Input to the PWM Comparator and Overcurrent Protection Comparator. The current-sense signal is compared to a signal proportional to the error-amplifier output voltage.
4	R_T/C_T	Timing Resistor and Capacitor Connection. A resistor R_T from R_T/C_T to V_{REF} and capacitor C_T from R_T/C_T to GND set the oscillator frequency.
5	GND	Power-Supply Ground. Place the V_{CC} and V_{REF} bypass capacitors close to the IC to minimize ground loops.
6	OUT	MOSFET Driver Output. OUT connects to the gate of the external n-channel MOSFET.
7	V_{CC}	Power-Supply Input for MAX5070. Bypass V_{CC} to GND with a $0.1\mu F$ ceramic capacitor or a parallel combination of a $0.1\mu F$ and a higher value ceramic capacitor.
8	V_{REF}	5V Reference Output. Bypass V_{REF} to GND with a $0.1\mu F$ ceramic capacitor or a parallel combination of a $0.1\mu F$ and a higher value ceramic capacitor.

High-Performance, Single-Ended, Current-Mode PWM Controllers

Pin Descriptions (continued)

MAX5071A/MAX5071B/MAX5071C

PIN		NAME	FUNCTION
MAX5071A/ MAX5071B	MAX5071C		
1	1	COMP	COMP is level-shifted and connected to the inverting input of the PWM comparator. Pull up COMP to VREF through a resistor and connect an optocoupler from COMP to GND for proper operation.
2	—	SYNC	Bidirectional Synchronization Input. When synchronizing with other MAX5071A/MAX5071Bs, the higher frequency part synchronizes all other devices.
—	2	ADV_CLK	ADV_CLK is an 85ns clock output pulse preceding the rising edge of OUT (see Figure 4). Use the pulse to drive the secondary-side synchronous rectifiers through a pulse transformer or an optocoupler (see Figure 8).
3	3	CS	Input to the PWM Comparator and Overcurrent Protection Comparator. The current-sense signal is compared to the voltage at COMP.
4	4	R _T /C _T	Timing Resistor and Capacitor Connection. A resistor R _T from R _T /C _T to VREF and capacitor C _T from R _T /C _T to GND set the oscillator frequency.
5	5	GND	Power-Supply Ground. Place the V _{CC} and VREF bypass capacitors close to the IC to minimize ground loops.
6	6	OUT	MOSFET Driver Output. OUT connects to the gate of the external n-channel MOSFET.
7	7	V _{CC}	Power-Supply Input for MAX5071. Bypass V _{CC} to GND with a 0.1μF ceramic capacitor or a parallel combination of a 0.1μF and a higher value ceramic capacitor.
8	8	VREF	5V Reference Output. Bypass VREF to GND with a 0.1μF ceramic capacitor or a parallel combination of a 0.1μF and a higher value ceramic capacitor.

High-Performance, Single-Ended, Current-Mode PWM Controllers

MAX5070/MAX5071

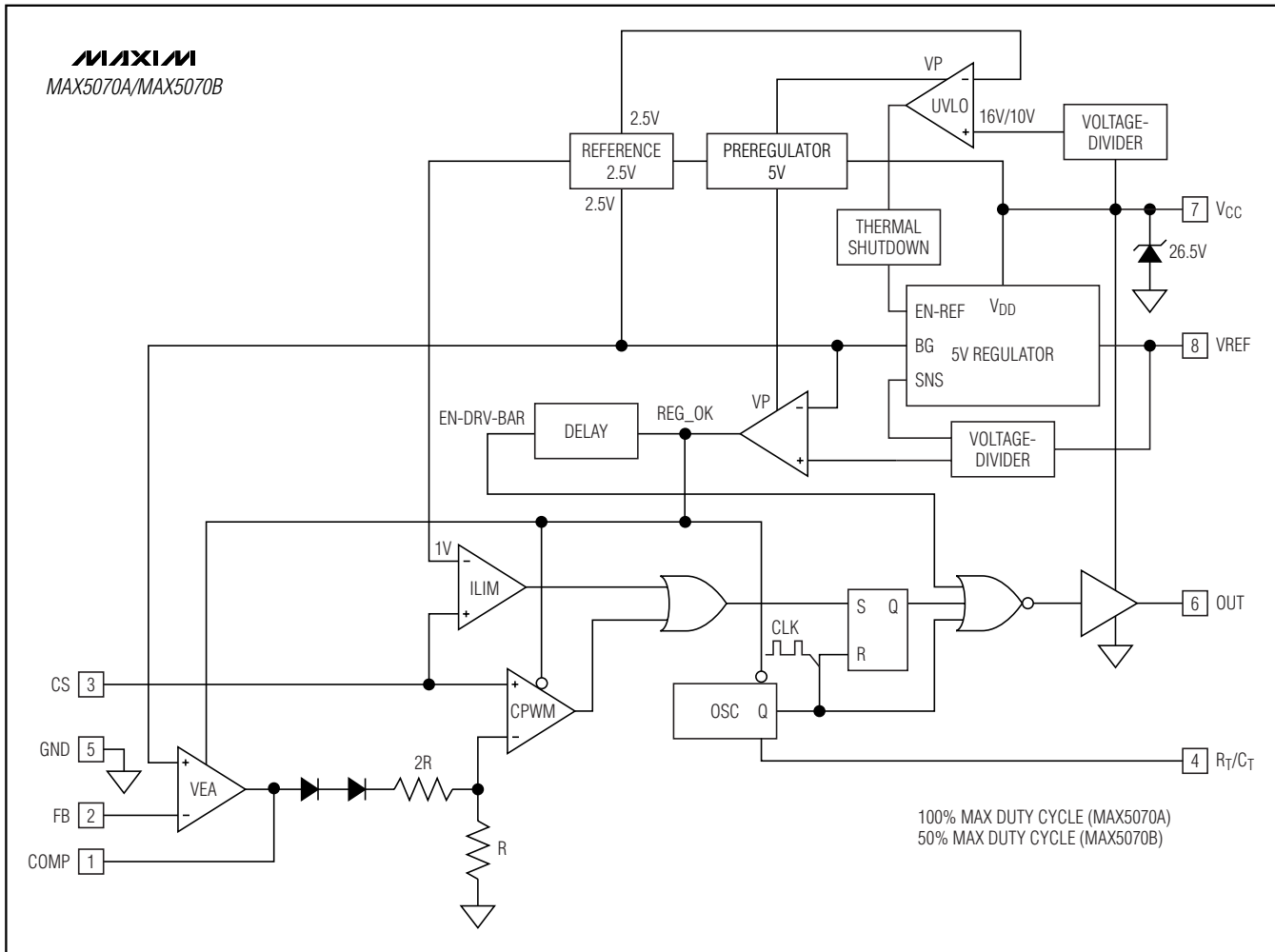

Figure 1. MAX5070A/MAX5070B Functional Diagram

Detailed Description

The MAX5070/MAX5071 current-mode PWM controllers are designed for use as the control and regulation core of flyback or forward topology switching power supplies. These devices incorporate an integrated low-side driver, adjustable oscillator, error amplifier (MAX5070A/MAX5070B only), current-sense amplifier, 5V reference, and external synchronization capability (MAX5071A/MAX5071B only). An internal +26.5V current-limited V_{CC} clamp prevents overvoltage during startup.

Five different versions of the MAX5070/MAX5071 are available. The MAX5070A/MAX5070B are the standard

versions with a feedback input (FB) and internal error amplifier. The MAX5071A/MAX5071B include bidirectional synchronization (SYNC). This enables multiple MAX5071A/MAX5071Bs to be connected and synchronized to the device with the highest frequency. The MAX5071C includes an ADV_CLK output, which precedes the MAX5071C's drive output (OUT) by 110ns. Figures 1, 2, and 3 show the internal functional diagrams of the MAX5070A/MAX5070B, MAX5071A/MAX5071B, and MAX5071C, respectively. The MAX5070A/MAX5071A are capable of 100% maximum duty cycle. The MAX5070B/MAX5071B/MAX5071C are designed to limit the maximum duty cycle to 50%.

High-Performance, Single-Ended, Current-Mode PWM Controllers

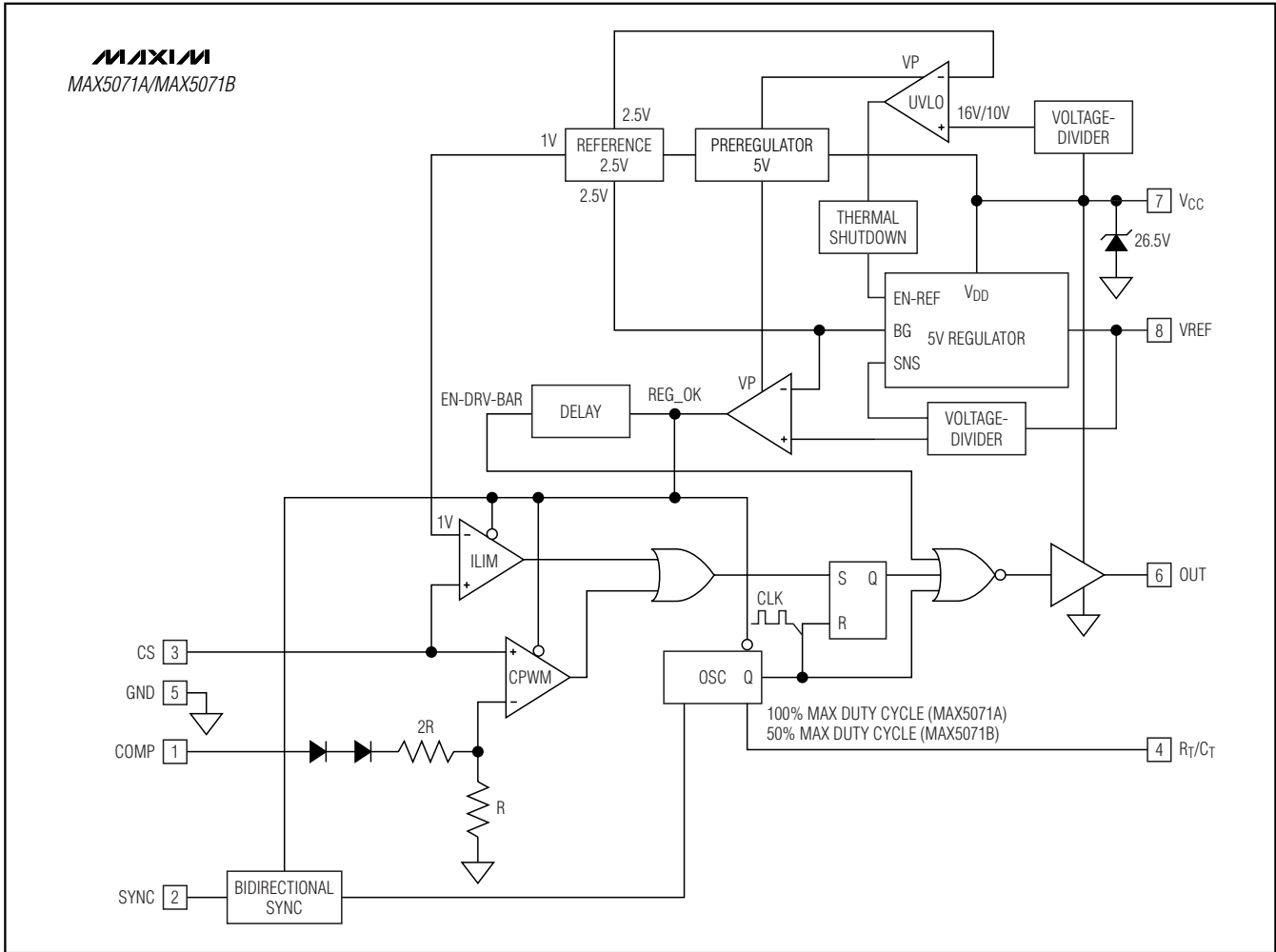

Figure 2. MAX5071A/MAX5071B Functional Diagram

Current-Mode Control Loop

The advantages of current-mode control over voltage-mode control are twofold. First, there is the feed-forward characteristic brought on by the controller's ability to adjust for variations in the input voltage on a cycle-by-cycle basis. Secondly, the stability requirements of the current-mode controller are reduced to that of a single-pole system unlike the double pole in the voltage-mode control scheme.

The MAX5070/MAX5071 use a current-mode control loop where the output of the error amplifier is compared to the current-sense voltage (V_{CS}). When the current-sense signal is lower than the noninverting input of the PWM comparator, the output of the CPWM comparator is low and the switch is turned on at each clock pulse. When the current-sense signal is higher than the inverting input of the CPWM, the output of the CPWM comparator is high and the switch is turned off.

High-Performance, Single-Ended, Current-Mode PWM Controllers

MAX5070/MAX5071

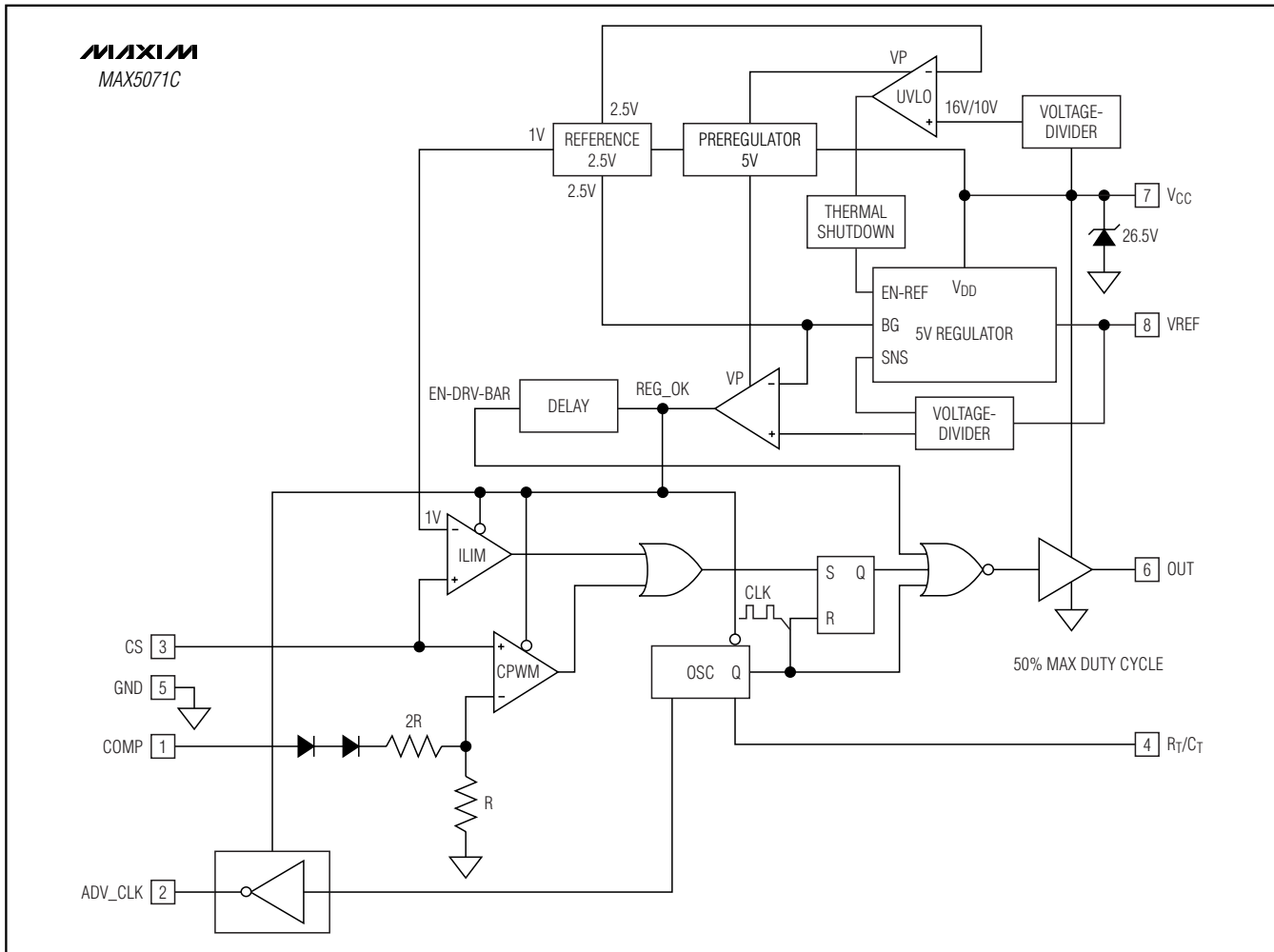

Figure 3. MAX5071C Functional Diagram

V_{CC} and Startup

In normal operation, V_{CC} is derived from a tertiary winding of the transformer. However, at startup there is no energy delivered through the transformer, thus a resistor must be connected from V_{CC} to the input power source (see R_{ST} and C_{ST} in Figures 5 to 8). During startup, C_{ST} charges up through R_{ST}. The 5V reference generator, comparator, error amplifier, oscillator, and drive circuit remain off during UVLO to reduce startup current below 65μA. When V_{CC} reaches the undervoltage-lockout threshold of 16V, the output driver begins to switch and the tertiary winding will supply power to V_{CC}. V_{CC} has an internal 26.5V current-limited clamp at its input to protect the device from overvoltage during startup.

Size the startup resistor, R_{ST}, to supply both the maximum startup bias (I_{START}) of the device (65μA max) and the charging current for C_{ST}. The startup capacitor C_{ST} must charge to 16V within the desired time period t_{ST} (for example, 500ms). The size of the startup capacitor depends on:

- 1) IC operating supply current at a programmed oscillator frequency (f_{OSC}).
- 2) The time required for the bias voltage, derived from a bias winding, to go from 0 to 11V.
- 3) The MOSFET total gate charge.
- 4) The operating frequency of the converter (f_{sw}).

High-Performance, Single-Ended, Current-Mode PWM Controllers

To calculate the capacitance required, use the following formula:

$$C_{ST} = \frac{\left[I_{CC} + I_G - \left(\frac{V_{INMIN} - 13V}{R_{ST}} \right) \right] (t_{SS})}{V_{HYST}}$$

where:

$$I_G = Q_G f_{SW}$$

I_{CC} is the MAX5070/MAX5071s' maximum internal supply current after startup (see the *Typical Operating Characteristics* to find the I_{IN} at a given f_{OSC}). Q_G is the total gate charge for the MOSFET, f_{SW} is the converter switching frequency, V_{HYST} is the bootstrap UVLO hysteresis (6V), and t_{SS} is the soft-start time, which is set by external circuitry.

Size the resistor R_{ST} according to the desired startup time period, t_{ST} , for the calculated C_{ST} . Use the following equations to calculate the average charging current (I_{CST}) and the startup resistor (R_{ST}).

$$I_{CST} = \frac{V_{SUVR} \times C_{ST}}{t_{ST}}$$

$$R_{ST} = \frac{\left(V_{INMIN} - \frac{V_{SUVR}}{2} \right)}{I_{CST} + I_{START}}$$

Where V_{INMIN} is the minimum input supply voltage for the application (36V for telecom), V_{SUVR} is the bootstrap UVLO wake-up level (16V), and I_{START} is the V_{IN} supply current at startup (65 μ A, max). Choose a higher value for R_{ST} than the one calculated above if longer startup times can be tolerated in order to minimize power loss in R_{ST} .

The above startup method is applicable to circuits where the tertiary winding has the same phase as the output windings. Thus, the voltage on the tertiary winding at any given time is proportional to the output voltage and goes through the same soft-start period as the output voltage. The minimum discharge time of C_{ST} from 16V to 10V must be greater than the soft-start time (t_{SS}).

Undervoltage Lockout (UVLO)

The minimum turn-on supply voltage for the MAX5070/MAX5071 is 16V. Once V_{CC} reaches 16V, the reference powers up. There is 6V of hysteresis from the minimum turn-on voltage to the UVLO threshold. Once V_{CC} reaches 16V, the MAX5070/MAX5071 will operate with V_{CC} down to 10V. Once V_{CC} goes below 10V the device is in UVLO. When in UVLO, the quiescent supply current into V_{CC} falls back to 37 μ A (typ), and OUT and VREF are pulled low.

MOSFET Driver

OUT drives an external n-channel MOSFET and swings from GND to V_{CC} . Ensure that V_{CC} remains below the absolute maximum V_{GS} rating of the external MOSFET. OUT is a push-pull output with the on-resistance of the PMOS typically 3.5 Ω and the on-resistance of the NMOS typically 4.5 Ω . The driver can source 2A typically and sink 1A typically. This allows for the MAX5070/MAX5071 to quickly turn on and off high gate-charge MOSFETs.

Bypass V_{CC} with one or more 0.1 μ F ceramic capacitors to GND, placed close to the MAX5070/MAX5071. The average current sourced to drive the external MOSFET depends on the total gate charge (Q_G) and operating frequency of the converter. The power dissipation in the MAX5070/MAX5071 is a function of the average output drive current (I_{DRIVE}). Use the following equation to calculate the power dissipation in the device due to I_{DRIVE} :

$$I_{DRIVE} = Q_G \times f_{SW}$$

$$PD = (I_{DRIVE} + I_{CC}) \times V_{CC}$$

where I_{CC} is the operating supply current. See the *Typical Operating Characteristics* for the operating supply current at a given frequency.

Error Amplifier (MAX5070A/MAX5070B)

The MAX5070 includes an internal error amplifier. The inverting input is at FB and the noninverting input is internally connected to a 2.5V reference. The internal error amplifier is useful for nonisolated converter design (see Figure 6) and isolated design with primary-side regulation through a bias winding (see Figure 5). In the case of a nonisolated power supply, the output voltage will be:

$$V_{OUT} = \left(1 + \frac{R1}{R2} \right) \times 2.5V$$

where R1 and R2 are from Figure 6.

High-Performance, Single-Ended, Current-Mode PWM Controllers

MAX5071A/MAX5071B/MAX5071C Feedback

The MAX5071A/MAX5071B/MAX5071C are designed to be used with either an external error amplifier when designed into a nonisolated converter or an error amplifier and optocoupler when designed into an isolated power supply. The COMP input is level-shifted and connected to the inverting terminal of the PWM comparator (CPWM). Connect the COMP pin to the output of the external error amplifier for nonisolated design. Pull COMP high externally to at least 5V (or VREF) and connect the optocoupler transistor as shown in Figures 7 and 8. COMP can be used for soft-start and also as a shutdown. See the *Typical Operating Characteristics* to find the turn-off COMP voltage at different temperatures. If the maximum external COMP voltage is below 4.9V, it may reduce the PWM current-limit threshold below 1V. Use the following equation to calculate minimum COMP voltage (V_{COMP}) required for a guaranteed peak primary current (I_{P-P}):

$$V_{COMP} = (3 \times I_{P-P} \times R_{CS}) + 1.95V$$

where R_{CS} is a current-sense resistor.

Oscillator

The oscillator frequency is adjusted by adding an external capacitor and resistor at R_T/C_T (see R_T and C_T in the *Typical Application Circuits*). R_T is connected from R_T/C_T to the 5V reference (VREF) and C_T is connected from R_T/C_T to GND. VREF charges C_T through R_T until its voltage reaches 2.8V. C_T then discharges through an 8.3mA internal current sink until C_T's voltage reaches 1.1V, at which time C_T is allowed to charge through R_T again. The oscillator's period will be the sum of the charge and discharge times of C_T. Calculate the charge time as:

$$t_C = 0.57 \times R_T \times C_T$$

The discharge time is then:

$$t_D = \frac{R_T \times C_T \times 10^3}{4.88 \times R_T - 1.8 \times 10^3}$$

The oscillator frequency will then be:

$$f_{OSC} = \frac{1}{t_C + t_D}$$

For the MAX5070A/MAX5071A, the converter output switching frequency (f_{sw}) is the same as the oscillator frequency (f_{osc}). For the MAX5070B/MAX5071B/MAX5071C, the output switching frequency is 1/2 the oscillator frequency.

Reference Output

VREF is a 5V reference output that can source 20mA. Bypass VREF to GND with a 0.1μF capacitor.

Current Limit

The MAX5070/MAX5071 include a fast current-limit comparator to terminate the ON cycle during an overload or a fault condition. The current-sense resistor (R_{CS}), connected between the source of the MOSFET and GND, sets the current limit. The CS input has a voltage trip level (V_{CS}) of 1V. Use the following equation to calculate R_{CS}:

$$R_{CS} = \frac{V_{CS}}{I_{P-P}}$$

I_{P-P} is the peak current in the primary that flows through the MOSFET. When the voltage produced by this current (through the current-sense resistor) exceeds the current-limit comparator threshold, the MOSFET driver (OUT) will turn the switch off within 60ns. In most cases, a small RC filter is required to filter out the leading-edge spike on the sense waveform. Set the time constant of the RC filter at 50ns. Use a current transformer to limit the losses in the current-sense resistor and achieve higher efficiency especially at low input-voltage operation.

Synchronization (MAX5071A/MAX5071B)

SYNC

SYNC is a bidirectional input/output that outputs a synchronizing pulse and accepts a synchronizing pulse from other MAX5071A/MAX5071Bs (see Figures 7 and 9). As an output, SYNC is an open-drain p-channel MOSFET driven from the internal oscillator and requires an external pulldown resistor (R_{SYNC}) from between 500Ω and 5kΩ. As an input, SYNC accepts the output pulses from other MAX5071A/MAX5071Bs.

Synchronize multiple MAX5071A/MAX5071Bs by connecting their SYNC pins together. All devices connected together will synchronize to the one operating at the highest frequency. The rising edge of SYNC will precede the rising edge of OUT by approximately the discharge time (t_D) of the oscillator (see the *Oscillator* section). The pulse width of the SYNC output is equal to the time required to discharge the stray capacitance at SYNC through R_{SYNC} plus the C_T discharge time t_D. Adjust R_T/C_T such that the minimum discharge time t_D is 200ns.

High-Performance, Single-Ended, Current-Mode PWM Controllers

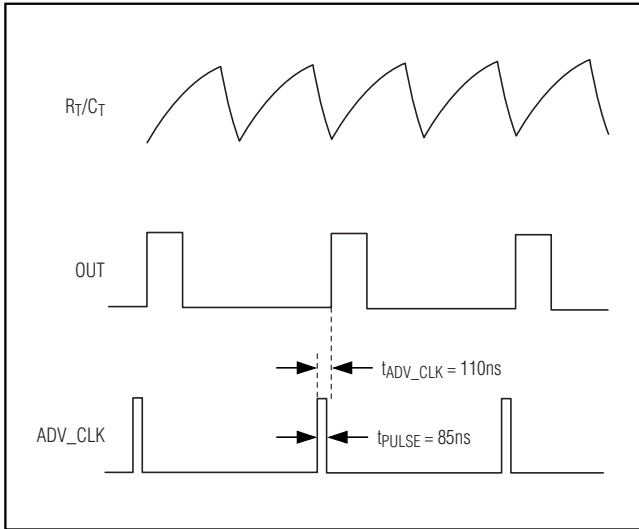

Figure 4. ADV_CLK

Advance Clock Output (ADV_CLK) (MAX5071C)

ADV_CLK is an advanced pulse output provided to facilitate the easy implementation of secondary-side synchronous rectification using the MAX5071C. The ADV_CLK pulse width is 85ns (typically) with its rising edge leading the rising edge of OUT by 110ns. Use this leading pulse to turn off the secondary-side synchronous-rectifier MOSFET (QS) before the voltage appears on the secondary (see Figure 8). Turning off the secondary-side synchronous MOSFET earlier avoids the shorting of the secondary in the forward converter. The ADV_CLK pulse can be propagated to the secondary side using a pulse transformer or high-speed optocoupler. The 85ns pulse, with 3V drive voltage (10mA source), significantly reduces the volt-second requirement of the pulse transformer and the advanced pulse alleviates the need for a high-speed optocoupler.

Thermal Shutdown

When the MAX5070/MAX5071s' die temperature goes above +150°C, the thermal-shutdown circuitry will shut down the 5V reference and pull OUT low.

Typical Application Circuits

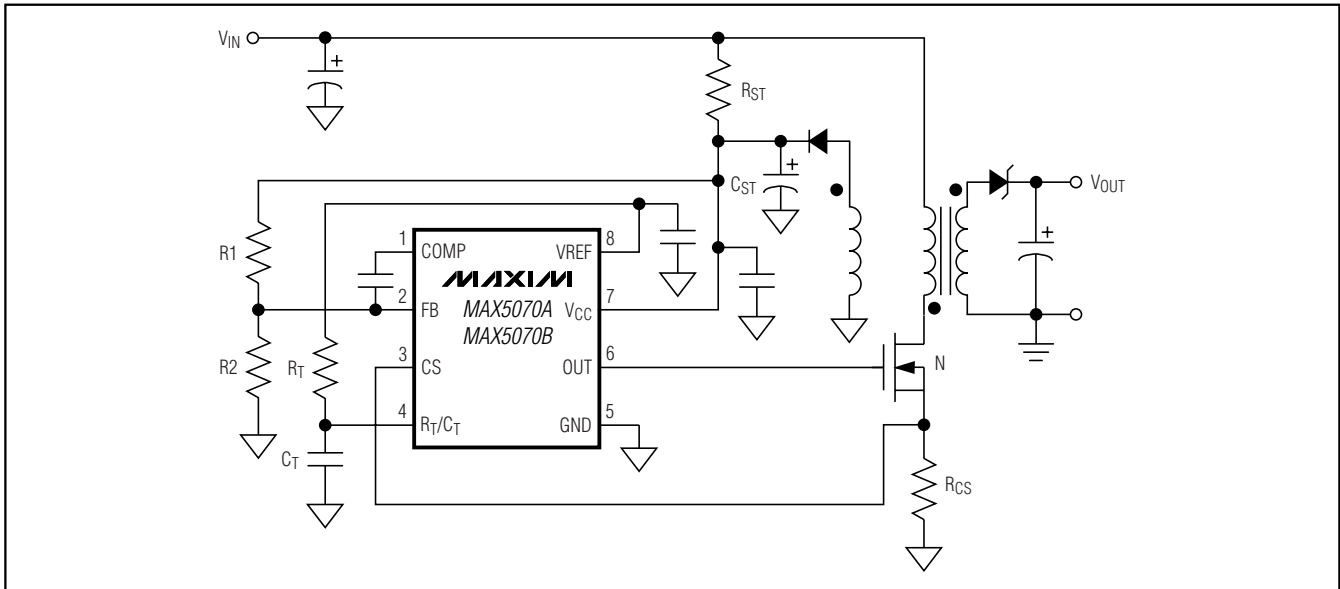

Figure 5. MAX5070A/MAX5070B Typical Application Circuit (Isolated Flyback with Primary-Side Regulation)

High-Performance, Single-Ended, Current-Mode PWM Controllers

Typical Application Circuits (continued)

MAX5070/MAX5071

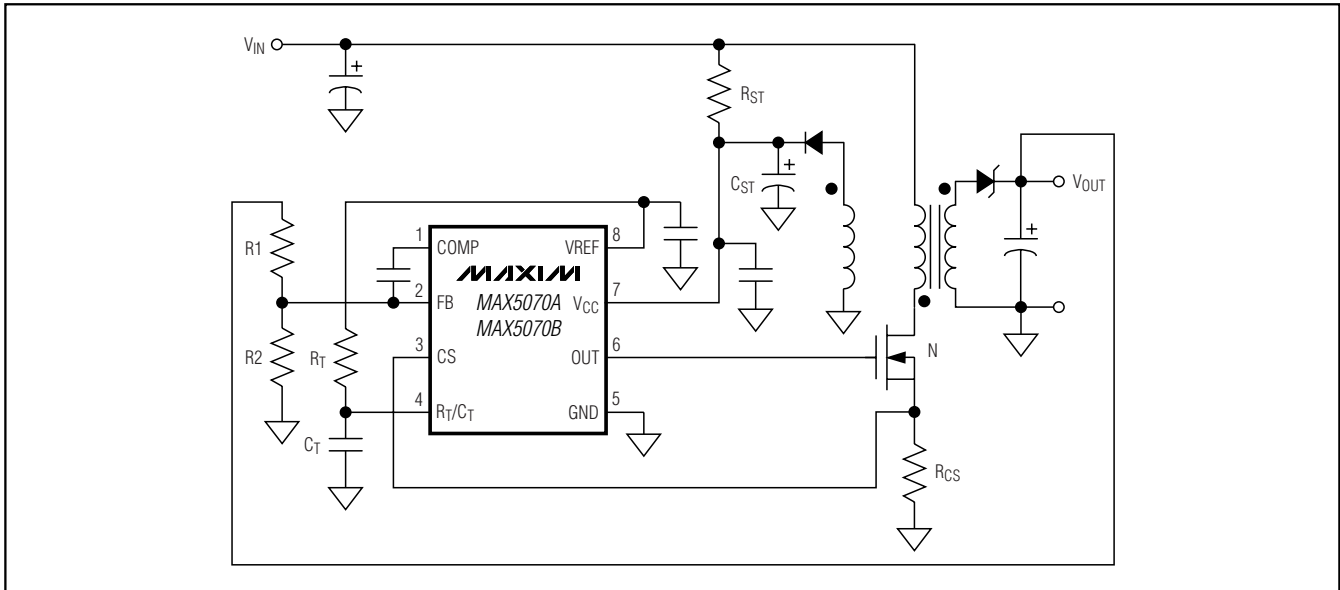

Figure 6. MAX5070A/MAX5070B Typical Application Circuit (Non-Isolated Flyback)

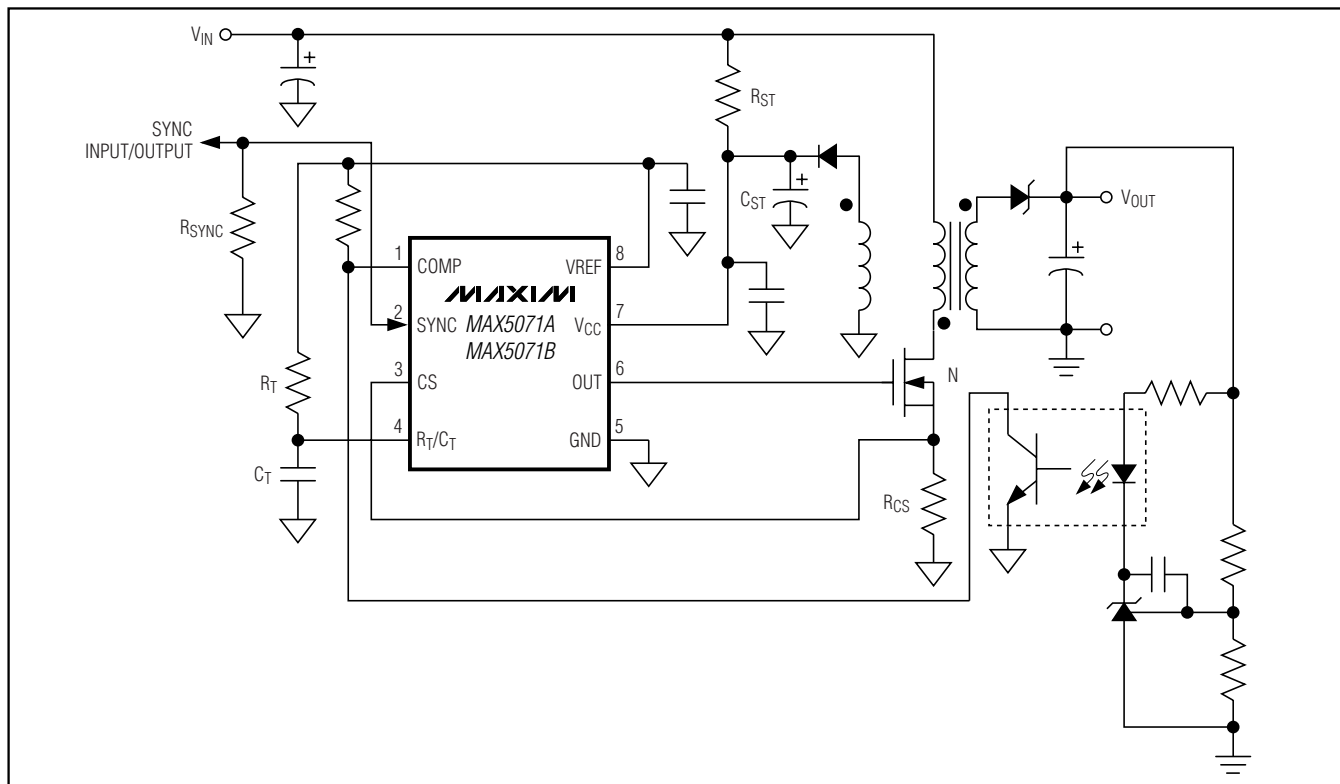

Figure 7. MAX5071A/MAX5071B Typical Application Circuit (Isolated Flyback)

High-Performance, Single-Ended, Current-Mode PWM Controllers

Typical Application Circuits (continued)

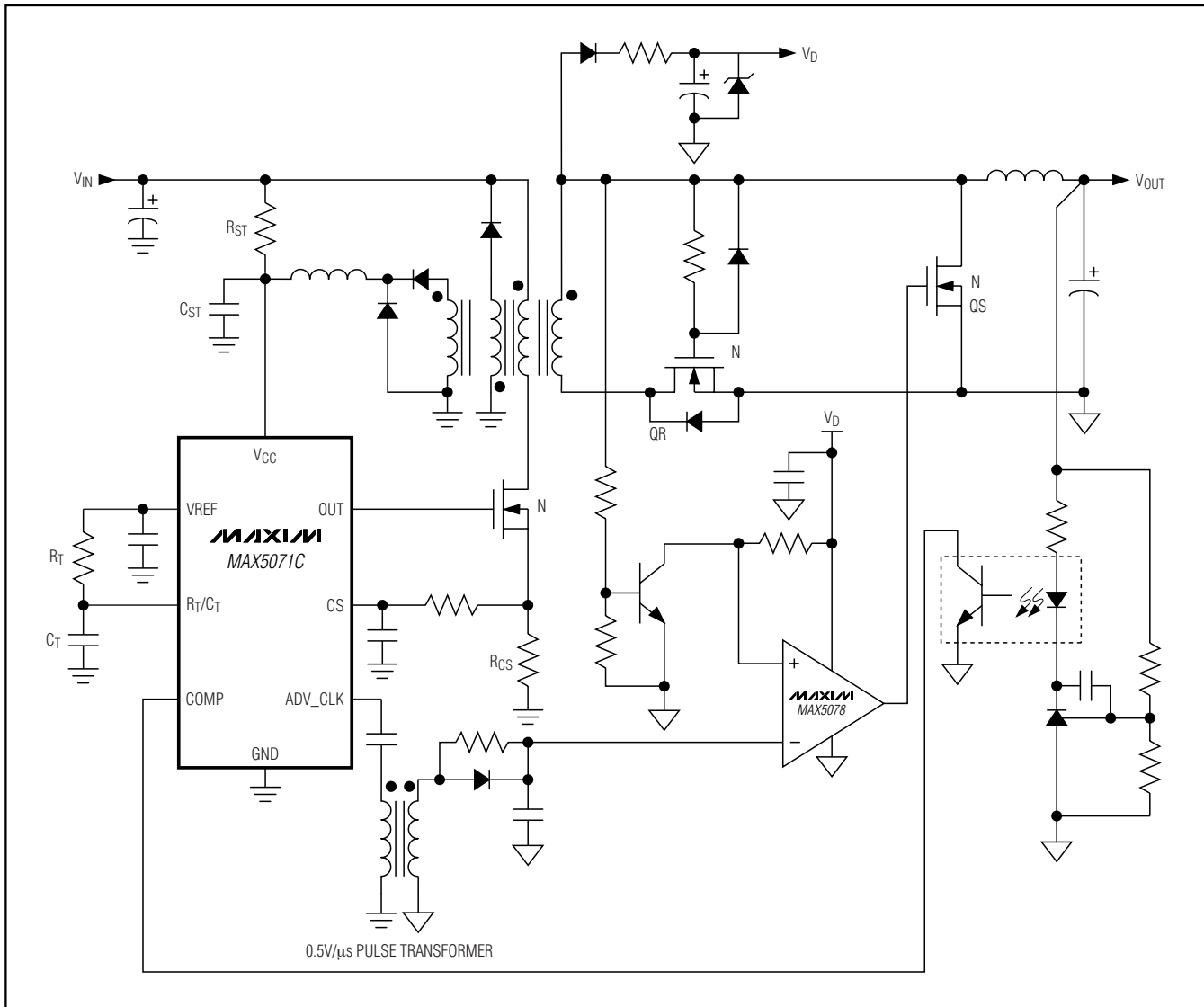

Figure 8. MAX5071C Typical Application Circuit (Isolated Forward with Secondary-Side Synchronous Rectification)

High-Performance, Single-Ended, Current-Mode PWM Controllers

MAX5070/MAX5071

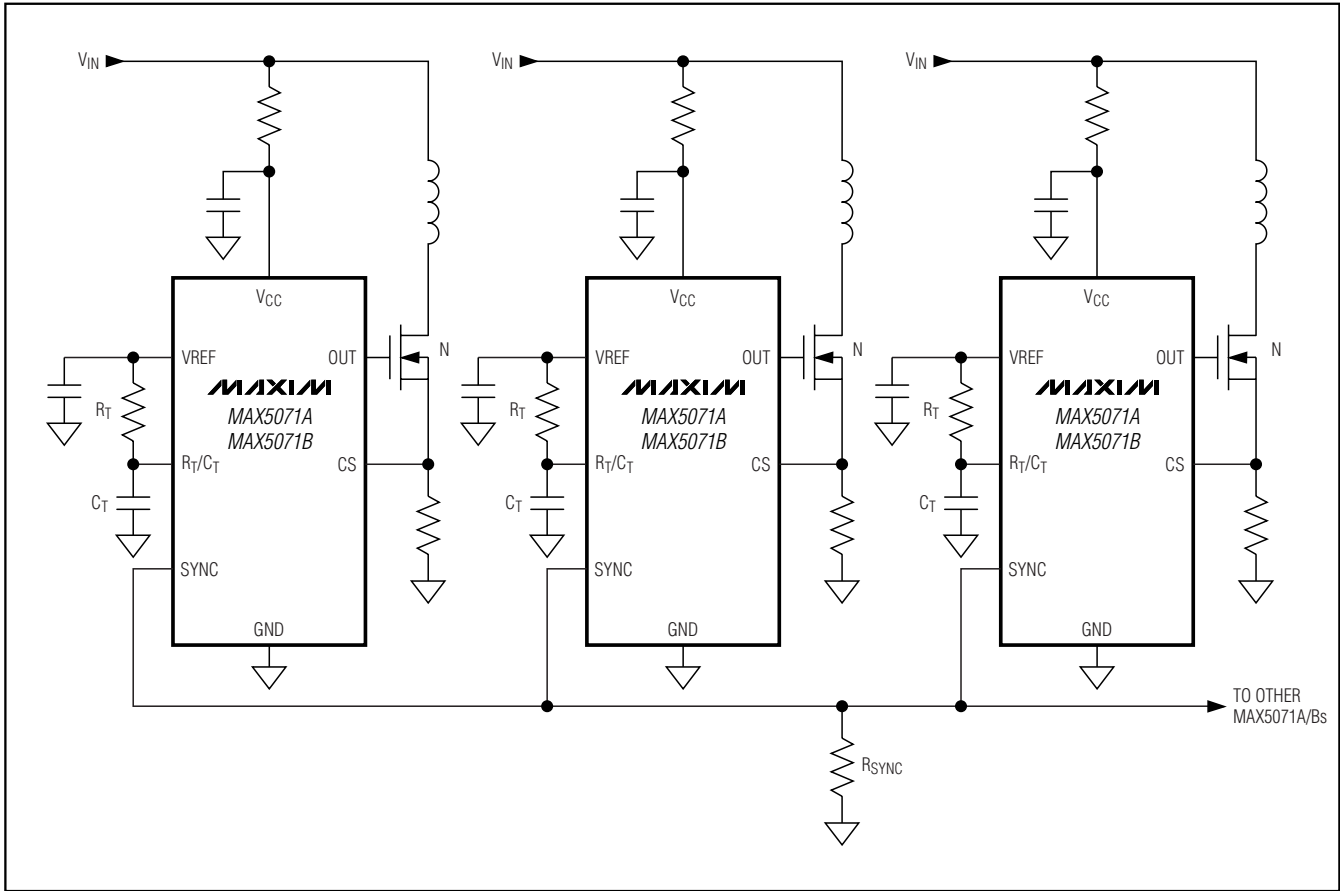

Figure 9. Synchronization of MAX5071s

High-Performance, Single-Ended, Current-Mode PWM Controllers

Selector Guide

PART	FEEDBACK/ ADVANCED CLOCK	MAXIMUM DUTY CYCLE (%)	PIN-PACKAGE	PIN COMPATIBLE
MAX5070AASA	Feedback	100	8 SO	UC2842/UCC2842
MAX5070AAUA	Feedback	100	8 μ MAX	UC2842/UCC2842
MAX5070BASA	Feedback	50	8 SO	UC2844/UCC2844
MAX5070BAUA	Feedback	50	8 μ MAX	UC2844/UCC2844
MAX5071AASA	Sync.	100	8 SO	—
MAX5071AAUA	Sync.	100	8 μ MAX	—
MAX5071BASA	Sync.	50	8 SO	—
MAX5071BAUA	Sync.	50	8 μ MAX	—
MAX5071CASA	ADV_CLK	50	8 SO	—
MAX5071CAUA	ADV_CLK	50	8 μ MAX	—

Pin Configurations (continued)

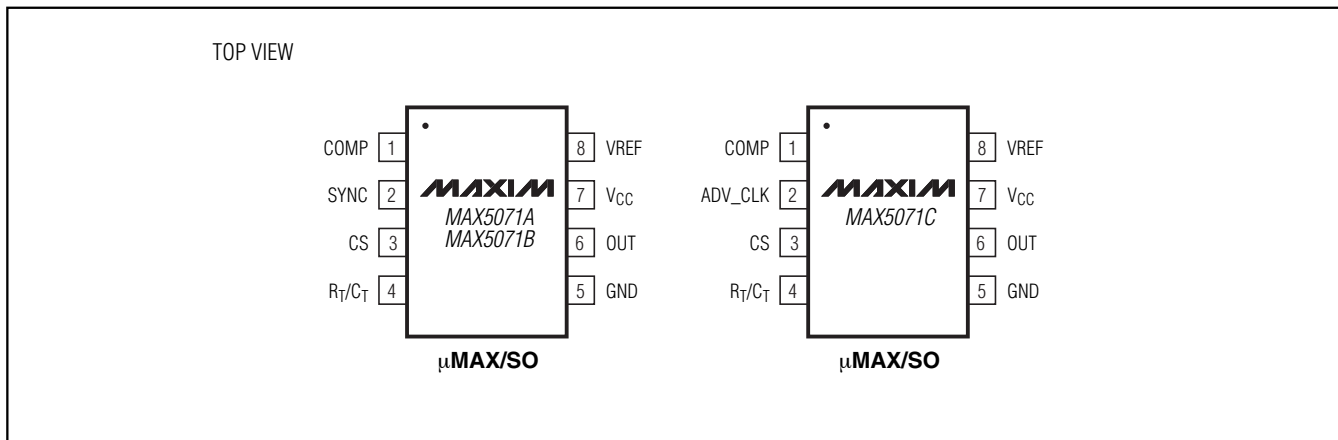

Ordering Information (continued)

PART	TEMP RANGE	PIN-PACKAGE
MAX5071AASA	-40°C to +125°C	8 SO
MAX5071AAUA	-40°C to +125°C	8 μ MAX
MAX5071BASA	-40°C to +125°C	8 SO
MAX5071BAUA	-40°C to +125°C	8 μ MAX
MAX5071CASA	-40°C to +125°C	8 SO
MAX5071CAUA	-40°C to +125°C	8 μ MAX

Specify lead-free by adding the + symbol at the end of the part number when ordering.

Chip Information

TRANSISTOR COUNT: 1987
PROCESS: BiCMOS

High-Performance, Single-Ended, Current-Mode PWM Controllers

Package Information

(The package drawing(s) in this data sheet may not reflect the most current specifications. For the latest package outline information go to www.maxim-ic.com/packages.)

MAX5070/MAX5071

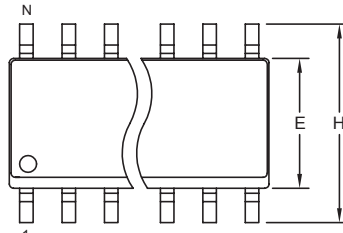

TOP VIEW

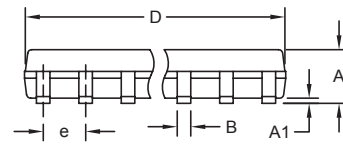

FRONT VIEW

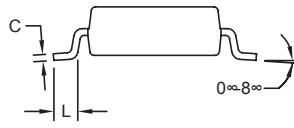

SIDE VIEW

DIM	INCHES		MILLIMETERS	
	MIN	MAX	MIN	MAX
A	0.053	0.069	1.35	1.75
A1	0.004	0.010	0.10	0.25
B	0.014	0.019	0.35	0.49
C	0.007	0.010	0.19	0.25
e	0.050 BSC		1.27 BSC	
E	0.150	0.157	3.80	4.00
H	0.228	0.244	5.80	6.20
L	0.016	0.050	0.40	1.27

VARIATIONS:

DIM	INCHES		MILLIMETERS		N	MS012
	MIN	MAX	MIN	MAX		
D	0.189	0.197	4.80	5.00	8	AA
D	0.337	0.344	8.55	8.75	14	AB
D	0.386	0.394	9.80	10.00	16	AC

NOTES:

1. D&E DO NOT INCLUDE MOLD FLASH.
2. MOLD FLASH OR PROTRUSIONS NOT TO EXCEED 0.15mm (.006").
3. LEADS TO BE COPLANAR WITHIN 0.10mm (.004").
4. CONTROLLING DIMENSION: MILLIMETERS.
5. MEETS JEDEC MS012.
6. N = NUMBER OF PINS.

DALLAS SEMICONDUCTOR
MAXIM

PROPRIETARY INFORMATION

TITLE:
PACKAGE OUTLINE, .150" SOIC

APPROVAL	DOCUMENT CONTROL NO. 21-0041	REV. B	1/1
----------	---------------------------------	-----------	-----

SOICN EP5

High-Performance, Single-Ended, Current-Mode PWM Controllers

Package Information (continued)

(The package drawing(s) in this data sheet may not reflect the most current specifications. For the latest package outline information go to www.maxim-ic.com/packages.)

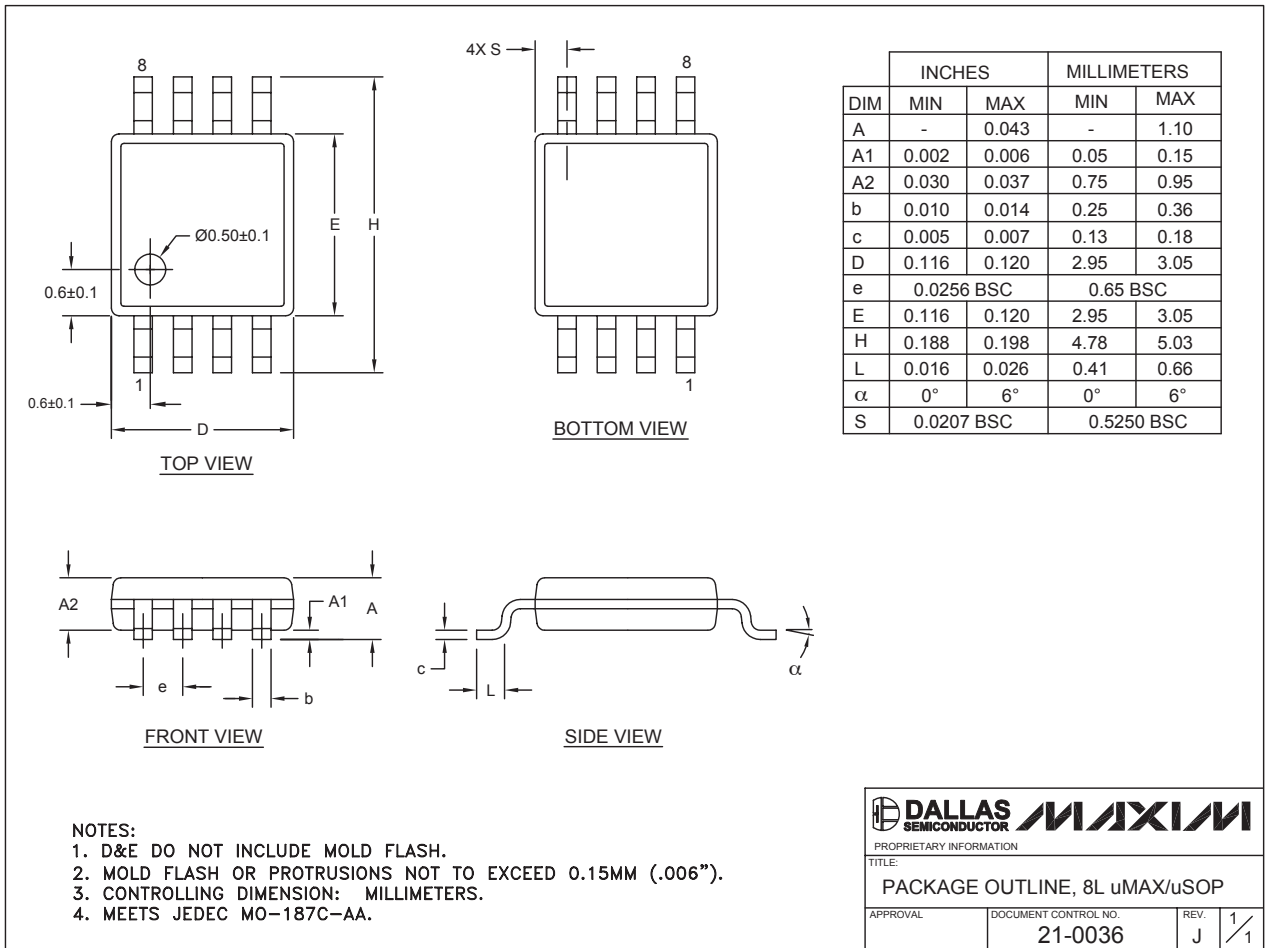

Maxim cannot assume responsibility for use of any circuitry other than circuitry entirely embodied in a Maxim product. No circuit patent licenses are implied. Maxim reserves the right to change the circuitry and specifications without notice at any time.

22 **Maxim Integrated Products, 120 San Gabriel Drive, Sunnyvale, CA 94086 408-737-7600**

Mouser Electronics

Authorized Distributor

Click to View Pricing, Inventory, Delivery & Lifecycle Information:

[Analog Devices Inc.:](#)

[MAX5071AASA+](#) [MAX5071AASA+T](#) [MAX5071AAUA+](#) [MAX5071AAUA+T](#) [MAX5071BASA+](#)