

P	LT#	DESCRIPTION	DATE	DMN	APVD
C		Revise per ECR-15-017013	20NOV15	LN	RS

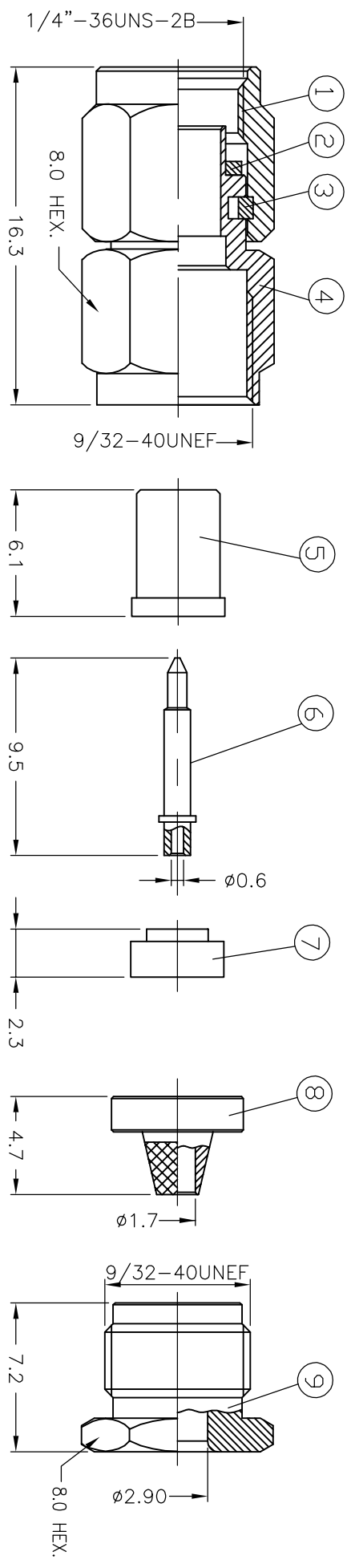

NOT RELEASED

- NOTES:
- ▲ SINGLE PACKING: ONE CONNECTOR PER LABELED BAG PACKAGED. LABELED PER TEC-107-115
 - ▲ TRAY PACKAGED
 - ▲ Au/NICKEL/COPPER
 - ▲ Au/NICKEL/COPPER
 - ▲ Au/NICKEL/COPPER
 - ▲ PASSIVATED

- 6 ELECTRICAL CHARACTERISTICS
- FREQUENCY RANGE: DC - 6 GHz
 - NOMINAL IMPEDANCE: 50 Ohm
 - INSULATION RESISTANCE: 5000 Mohm Min
 - WORKING VOLTAGE: 355 VRMS at Sea Level
 - DIELECTRIC WITHSTAND VOLTAGE: 500 V Max
 - CONTACT RESISTANCE: 3 mohm Max
 - CENTER CONTACT: 2 mohm Max
 - OUTER CONTACT: 1.3 Max @ 6GHz
 - VSWR @ 4GHz:

- 7 MECHANICAL CHARACTERISTICS
- COUPLING RETENTION FORCE: 60 lbs Min
 - COUPLING TORQUE: 15 in-lbs
 - DURABILITY: 500 Cycles Min
- 8 ENVIRONMENTAL CHARACTERISTICS
- OPERATING TEMPERATURE: -55 to +125 °C

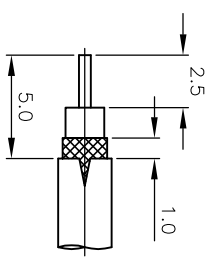

RECOMMENDED CABLE STRIPPING DIM'S

QTY	DMN	CHK	NAME	MATERIAL	DESCRIPTION	ITEM
1	1		STAINLESS STEEL	▲	NUT	9
-	-		STAINLESS STEEL	▲	NUT	9
1	1		STAINLESS STEEL	▲	CLAMP	8
-	-		STAINLESS STEEL	▲	CLAMP	8
1	1		PTFE	▲	INSULATOR 2	7
1	1		PTFE	▲	INSULATOR 2	7
1	1		BRASS	▲	CENTER CONTACT	6
1	1		PTFE	▲	INSULATOR 1	5
1	1		STAINLESS STEEL	▲	BODY	4
-	-		STAINLESS STEEL	▲	BODY	4
1	1		STAINLESS STEEL	▲	CIRCLIP	3
-	-		STAINLESS STEEL	▲	CIRCLIP	3
1	1		SILICONE	▲	GASKET	2
1	1		STAINLESS STEEL	▲	SHELL	1
-	-		STAINLESS STEEL	▲	SHELL	1
2	1		MATERIAL	▲	DESCRIPTION	ITEM

THIS DRAWING IS A CONTROLLED DOCUMENT.

DMN	10FE804	NAME	SMA STRAIGHT PLUG, JACK SOLDER PIN, CLAMP ATTACHMENT
CHK	R. SMITH	DATE	20NOV15
APVD	S. PARLOW	SCALE	5:1
PRODUCT SPEC	F. WHEELER-KING	DRAWING NO	408-32075
APPLICATION SPEC	408-32075	RESTRICTED TO	

DIMENSIONS:	TOLERANCES UNLESS OTHERWISE SPECIFIED:
mm	± .02
	± .01
	± .005
	± .002
	± .001
	± .0005
	± .0002
	± .0001
	± .00005

MATERIAL	FINISH
SEE TABLE	-

DMN	10FE804	SCALE	5:1
CHK	R. SMITH	DRAWING NO	408-32075
APVD	S. PARLOW	RESTRICTED TO	
PRODUCT SPEC	F. WHEELER-KING	DATE	20NOV15
APPLICATION SPEC	408-32075	DRAWING NO	408-32075
MATERIAL	SEE TABLE	RESTRICTED TO	



SMA STRAIGHT PLUG, JACK SOLDER PIN, CLAMP ATTACHMENT