

## Description

The AP2202 is a 150mA ULDO regulator which provides very low noise, ultra-low dropout voltage (typically 165mV at 150mA), very low standby current (1µA maximum), and excellent power supply ripple rejection (PSRR 75dB at 100Hz). This device is used in battery powered applications, such as handsets and PDAs; and in noise sensitive applications, such as RF electronics.

The AP2202 also features logic-compatible enable/shutdown control inputs, a low power shutdown mode for extended battery life, over-current protection, over-temperature protection, and reversed current protection.

The AP2202 has adjustable, 2.5V, 2.6V, 2.8V, 3.0V, and 3.3V versions.

The AP2202 is available in the space saving SOT-23-5 and SOT-89 packages.

## Features

- Up to 150mA Output Current
- Low Standby Current
- Low Dropout Voltage:  $V_{DROP} = 165mV$  at 150mA
- High Output Accuracy:  $\pm 1\%$
- Good Ripple Rejection Ability: 75dB at 100Hz and  $I_{OUT} = 100\mu A$
- Tight Load and Line Regulation
- Low Temperature Coefficient
- Over-Current Protection
- Thermal Protection
- Reverse Current Protection
- Logic-Controlled Enable
- Moisture Sensitivity: Level 3 Per J-STD-020
- Terminals: SOT-23-5/ SOT-89 Finish—Matte Tin Plated Leads, Solderable per MIL-STD-202, Method 208 
- Weight:
  - SOT-23-5: 0.015 grams (Approximate)
  - SOT-89: 0.055 grams (Approximate)
- Lead-Free Packages: SOT-23-5, SOT-89
  - **Totally Lead-Free; RoHS Compliant (Notes 1 & 2)**
- Lead-Free Packages, Available in “Green” Molding Compound: SOT-23-5, SOT-89
  - **Totally Lead-Free & Fully RoHS Compliant (Notes 1 & 2)**
  - **Halogen- and Antimony-Free. “Green” Device (Note 3)**
- **For automotive applications requiring specific change control (i.e. parts qualified to AEC-Q100/101/200, PPAP capable, and manufactured in IATF 16949 certified facilities), please [contact us](#) or your local Diodes representative. <https://www.diodes.com/quality/product-definitions/>**

Notes: 1. No purposely added lead. Fully EU Directive 2002/95/EC (RoHS), 2011/65/EU (RoHS 2) & 2015/863/EU (RoHS 3) compliant.  
 2. See <https://www.diodes.com/quality/lead-free/> for more information about Diodes Incorporated's definitions of Halogen- and Antimony-free, "Green" and Lead-free.  
 3. Halogen- and Antimony-free "Green" products are defined as those which contain <900ppm bromine, <900ppm chlorine (<1500ppm total Br + Cl) and <1000ppm antimony compounds.

## Pin Assignments

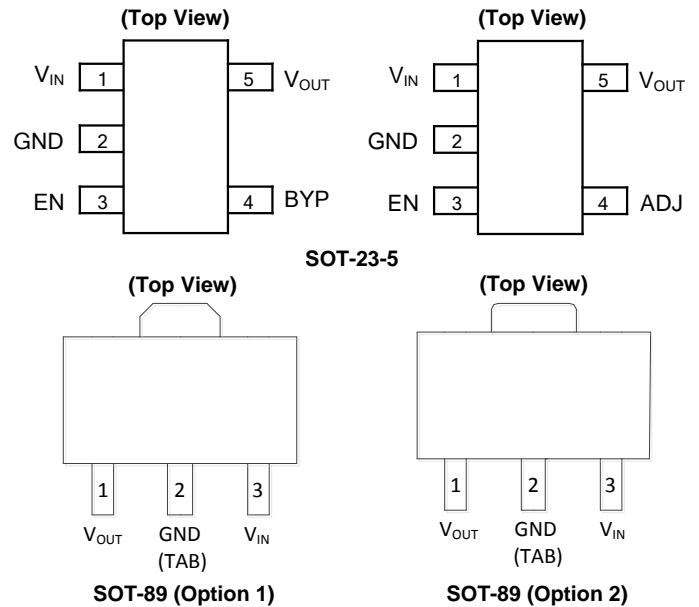

## Applications

- Cellular Phones
- Cordless Phones
- Digital Still Cameras
- Wireless Communicators
- PDAs / Palmtops
- PC Mother Board
- Consumer Electronics

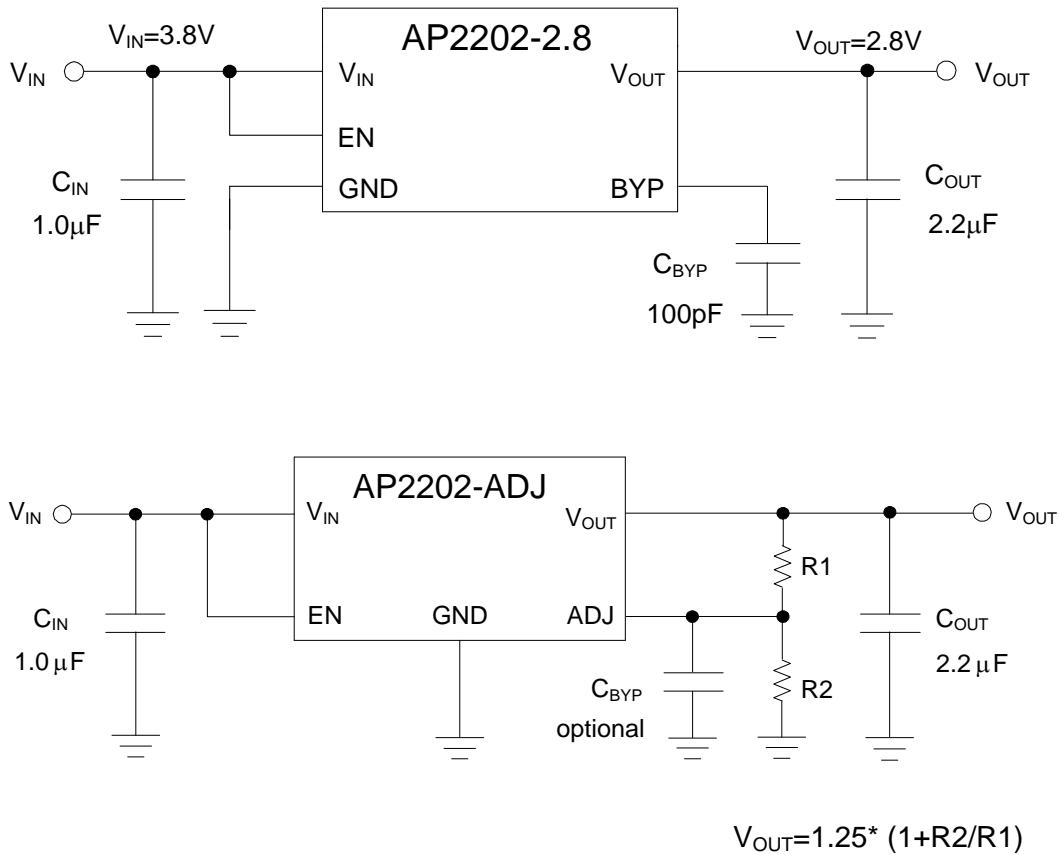
**Typical Applications Circuit** (Note 4)

Notes: 4. Dropout voltage is 165mV when  $T_A = +25^\circ\text{C}$ . In order to obtain a normal output voltage,  $V_{OUT} + 0.165\text{V}$  is the minimum input voltage which will result a low PSRR, imposing a bad influence on system. Therefore, the recommended input voltage is  $V_{OUT} + 0.5\text{V}$  to 13.2V. For AP2202-2.8 version, its input voltage can be set from 3.3V ( $V_{OUT} + 0.5\text{V}$ ) to 13.2V. For that of ADJ version, any value from  $V_{OUT} + 0.5\text{V}$  to 13.2V is available. R1 and R2 must be correctly selected when setting the output voltage. For example, if 3.0V output voltage is required, R1 and R2 can be set to 10k $\Omega$  and 14k $\Omega$  respectively. For ADJ version, we recommend 2.3V as minimum output voltage.

**Pin Descriptions**

Pin Number		Pin Name	Function
SOT-23-5	SOT-89		
1	3	$V_{IN}$	Input voltage
2	2	GND	Ground (TAB for SOT-89)
3	—	EN	Enable input: CMOS or TTL compatible input. Logic high=enable, logic low=shutdown
4	—	BYP/ADJ	Bypass capacitor for low noise operation/Adjust output
5	1	$V_{OUT}$	Regulated output voltage

**Functional Block Diagram**

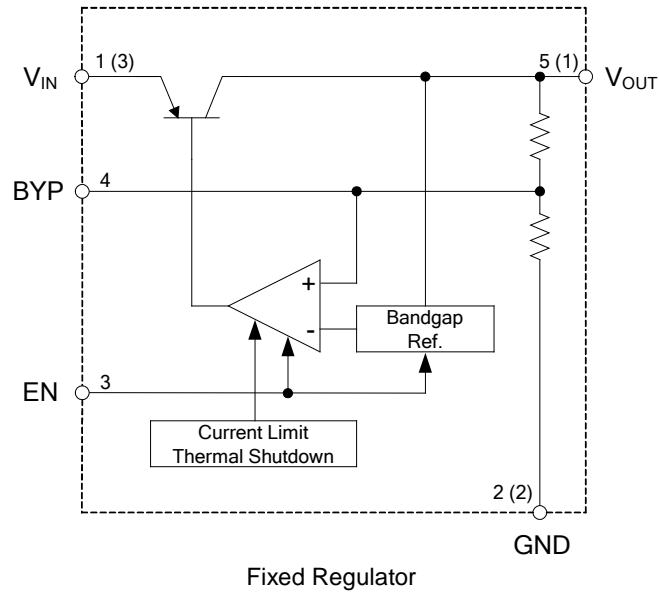

A (B)  
A for SOT-23-5  
B for SOT-89

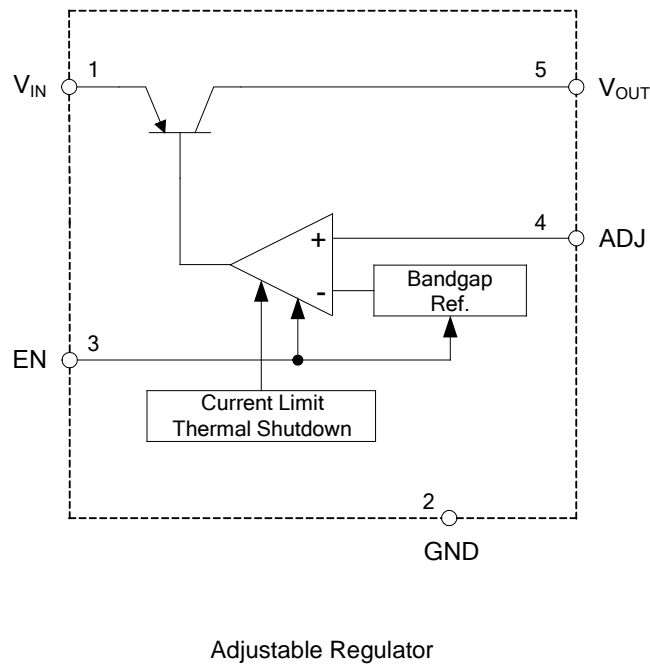

### Absolute Maximum Ratings (Note 5)

Symbol	Parameter	Rating		Unit
V <sub>IN</sub>	Supply Input Voltage	15		V
V <sub>EN</sub>	Enable Input Voltage	15		V
P <sub>D</sub>	Power Dissipation	Internally Limited (Thermal Protection)		W
T <sub>LEAD</sub>	Lead Temperature (Soldering, 10sec)	+260		°C
T <sub>J</sub>	Junction Temperature	+150		°C
T <sub>STG</sub>	Storage Temperature	-65 to +150		°C
—	ESD (Machine Model)	200		V
θ <sub>JA</sub>	Thermal Resistance (No Heatsink)	SOT-23-5	200	°C/W
		SOT-89	165	

Notes: 5. Stresses greater than those listed under "Absolute Maximum Ratings" may cause permanent damage to the device. These are stress ratings only, and functional operation of the device at these or any other conditions beyond those indicated under "Recommended Operating Conditions" is not implied. Exposure to "Absolute Maximum Ratings" for extended periods may affect device reliability.

### Recommended Operating Conditions

Symbol	Parameter	Min	Max	Unit
V <sub>IN</sub>	Supply Input Voltage	2.5	13.2	V
V <sub>EN</sub>	Enable Input Voltage	0	13.2	V
T <sub>J</sub>	Operating Junction Temperature	-40	+125	°C

**AP2202-ADJ Electrical Characteristics** (@ $V_{IN} = V_{OUT} + 1V$ ,  $I_{OUT} = 100\mu A$ ,  $C_{IN} = 1.0\mu F$ ,  $C_{OUT} = 2.2\mu F$ ,  $V_{EN} \geq 2.0V$ ,  $T_J = +25^\circ C$ , **Bold** typeface applies over  $-40^\circ C \leq T_J \leq +125^\circ C$  (Note 6), unless otherwise specified.)

Symbol	Parameter	Conditions	Min	Typ	Max	Unit
$\Delta V_{OUT}/V_{OUT}$	Output Voltage Accuracy	Variation from specified $V_{OUT}$	-1	—	1	%
			<b>-2</b>	—	<b>2</b>	
$\Delta V_{OUT}/\Delta T$	Output Voltage Temperature Coefficient (Note 7)	—	—	<b>120</b>	—	$\mu V/^\circ C$
$V_{RLINE}$	Line Regulation	$V_{IN} = V_{OUT} + 1V$ to 13.2V	—	0.004	0.012	%/V
			—	—	<b>0.05</b>	
$V_{RLOAD}$	Load Regulation (Note 8)	$I_{OUT} = 0.1mA$ to 150mA	—	0.02	0.2	%
			—	—	<b>0.5</b>	
$V_{DROP}$	Dropout Voltage (Note 9)	$I_{OUT} = 100\mu A$	—	15	50	mV
		$I_{OUT} = 50mA$	—	110	150	
			—	—	<b>230</b>	
		$I_{OUT} = 100mA$	—	140	250	
—	—		<b>300</b>			
$I_{STD}$	Standby Current	$V_{EN} \leq 0.4V$ (shutdown)	—	0.01	1	$\mu A$
		$V_{EN} \leq 0.18V$ (shutdown)	—	—	<b>5</b>	
$I_{GND}$	Ground Pin Current (Note 10)	$V_{EN} \geq 2.0V$ , $I_{OUT} = 0\mu A$	—	95	130	$\mu A$
			—	—	<b>150</b>	
		$V_{EN} \geq 2.0V$ , $I_{OUT} = 100\mu A$	—	98	140	
			—	—	<b>160</b>	
		$V_{EN} \geq 2.0V$ , $I_{OUT} = 50mA$	—	350	600	
			—	—	<b>800</b>	
$V_{EN} \geq 2.0V$ , $I_{OUT} = 100mA$	—	600	1000			
	—	—	<b>1500</b>			
$V_{EN} \geq 2.0V$ , $I_{OUT} = 150mA$	—	1300	1900			
	—	—	<b>2500</b>			
PSRR	Ripple Rejection	Frequency = 100Hz, $I_{OUT} = 100\mu A$	—	75	—	dB
$I_{LIMIT}$	Current Limit	$V_{OUT} = 0V$	—	<b>320</b>	550	mA
$e_{no}$	Output Noise	$I_{OUT} = 50mA$ , $C_{OUT} = 2.2\mu F$ , 100pF from BYP to GND	—	260	—	$nV/\sqrt{Hz}$

**AP2202-ADJ Electrical Characteristics** (Cont.) (@ $V_{IN} = V_{OUT} + 1V$ ,  $I_{OUT} = 100\mu A$ ,  $C_{IN} = 1.0\mu F$ ,  $C_{OUT} = 2.2\mu F$ ,  $V_{EN} \geq 2.0V$ ,  $T_J = +25^\circ C$ , **Bold** typeface applies over  $-40^\circ C \leq T_J \leq +125^\circ C$  (Note 6), unless otherwise specified.)

Symbol	Parameter	Conditions	Min	Typ	Max	Unit
$V_{IL}$	Enable Input Logic-Low Voltage	Regulator Shutdown	—	—	0.4	V
			—	—	<b>0.18</b>	
$V_{IH}$	Enable Input Logic-High Voltage	Regulator Enabled	<b>2.0</b>	—	—	V
$I_{IL}$	Enable Input Logic-Low Current	$V_{IL} \leq 0.4V$	—	0.01	1	$\mu A$
		$V_{IL} \leq 0.18V$	—	—	<b>2</b>	
$I_{IH}$	Enable Input Logic-High Current	$V_{IH} \geq 2.0V$	—	5	20	$\mu A$
		$V_{IH} \geq 2.0V$	—	—	<b>25</b>	
$\theta_{JC}$	Thermal Resistance	SOT-23-5	—	63.4	—	$^\circ C/W$
		SOT-89	—	50	—	

- Notes:
- Specifications in bold type are limited to  $-40^\circ C \leq T_J \leq +125^\circ C$ . Limits over temperature are guaranteed by design, but not tested in production.
  - Output voltage temperature coefficient is defined as the worst case voltage change divided by the total temperature range.
  - Regulation is measured at constant junction temperature using low duty cycle pulse testing. Parts are tested for load regulation in the load range from 0.1mA to 150mA. Changes in output voltage due to heating effects are covered by the thermal regulation specification.
  - Dropout voltage is defined as the input to output differential at which the output voltage drops 1% ( $T_J = +25^\circ C$ ) or 2% ( $-40^\circ C \leq T_J \leq +125^\circ C$ ) below its nominal value measured at 1V differential.
  - Ground pin current is the regulator quiescent current plus pass transistor base current. The total current drawn from the supply is the sum of the load current plus the ground pin current.

**AP2202-2.5 Electrical Characteristics** (@ $V_{IN} = 3.5V$ ,  $I_{OUT} = 100\mu A$ ,  $C_{IN} = 1.0\mu F$ ,  $C_{OUT} = 2.2\mu F$ ,  $V_{EN} \geq 2.0V$ ,  $T_J = +25^\circ C$ , **Bold** typeface applies over  $-40^\circ C \leq T_J \leq +125^\circ C$  (Note 6), unless otherwise specified.)

Symbol	Parameter	Conditions	Min	Typ	Max	Unit
$\Delta V_{OUT}/V_{OUT}$	Output Voltage Accuracy	Variation from specified $V_{OUT}$	-1	—	1	%
			<b>-2</b>	—	<b>2</b>	
$\Delta V_{OUT}/\Delta T$	Output Voltage Temperature Coefficient (Note 7)	—	—	<b>120</b>	—	$\mu V/^\circ C$
$(\Delta V_{OUT}/V_{OUT})/\Delta T$		—	—	<b>48</b>	—	ppm/ $^\circ C$
$V_{RLINE}$	Line Regulation	$V_{IN} = 3.5V$ to $13.2V$	—	1	3	mV
			—	—	<b>13</b>	
$V_{RLOAD}$	Load Regulation (Note 8)	$I_{OUT} = 0.1mA$ to $150mA$	—	1	5	mV
			—	—	<b>13</b>	
$V_{DROP}$	Dropout Voltage (Note 9)	$I_{OUT} = 100\mu A$	—	15	50	mV
			—	—	<b>70</b>	
		$I_{OUT} = 50mA$	—	110	150	
			—	—	<b>230</b>	
		$I_{OUT} = 100mA$	—	140	250	
			—	—	<b>300</b>	
$I_{OUT} = 150mA$	—	165	275			
	—	—	<b>350</b>			
$I_{STD}$	Standby Current	$V_{EN} \leq 0.4V$ (shutdown)	—	0.01	1	$\mu A$
		$V_{EN} \leq 0.18V$ (shutdown)	—	—	<b>5</b>	
$I_{GND}$	Ground Pin Current (Note 10)	$V_{EN} \geq 2.0V$ , $I_{OUT} = 0\mu A$	—	95	130	$\mu A$
			—	—	<b>150</b>	
		$V_{EN} \geq 2.0V$ , $I_{OUT} = 100\mu A$	—	98	140	
			—	—	<b>160</b>	
		$V_{EN} \geq 2.0V$ , $I_{OUT} = 50mA$	—	350	600	
			—	—	<b>800</b>	
$V_{EN} \geq 2.0V$ , $I_{OUT} = 100mA$	—	600	1000			
	—	—	<b>1500</b>			
$V_{EN} \geq 2.0V$ , $I_{OUT} = 150mA$	—	1300	1900			
	—	—	<b>2500</b>			
PSRR	Ripple Rejection	Frequency = 100Hz, $I_{OUT} = 100\mu A$	—	75	—	dB
$I_{LIMIT}$	Current Limit	$V_{OUT} = 0V$	—	<b>320</b>	550	mA
$e_{no}$	Output Noise	$I_{OUT} = 50mA$ , $C_{OUT} = 2.2\mu F$ , 100pF from BYP to GND	—	260	—	$nV/\sqrt{Hz}$

**AP2202-2.5 Electrical Characteristics** (Cont.) (@ $V_{IN} = 3.5V$ ,  $I_{OUT} = 100\mu A$ ,  $C_{IN} = 1.0\mu F$ ,  $C_{OUT} = 2.2\mu F$ ,  $V_{EN} \geq 2.0V$ ,  $T_J = +25^\circ C$ , **Bold** typeface applies over  $-40^\circ C \leq T_J \leq +125^\circ C$  (Note 6), unless otherwise specified.)

Symbol	Parameter	Conditions	Min	Typ	Max	Unit
$V_{IL}$	Enable Input Logic-Low Voltage	Regulator Shutdown	—	—	0.4	V
			—	—	<b>0.18</b>	
$V_{IH}$	Enable Input Logic-High Voltage	Regulator enabled	<b>2.0</b>	—	—	V
$I_{IL}$	Enable Input Logic-Low Current	$V_{IL} \leq 0.4V$	—	0.01	1	$\mu A$
		$V_{IL} \leq 0.18V$	—	—	<b>2</b>	
$I_{IH}$	Enable Input Logic-High Current	$V_{IH} \geq 2.0V$	—	5	20	$\mu A$
		$V_{IH} \geq 2.0V$	—	—	<b>25</b>	
$\theta_{JC}$	Thermal Resistance	SOT-23-5	—	63.4	—	$^\circ C/W$
		SOT-89	—	50	—	

- Notes:
- Specifications in bold type are limited to  $-40^\circ C \leq T_J \leq +125^\circ C$ . Limits over temperature are guaranteed by design, but not tested in production.
  - Output voltage temperature coefficient is defined as the worst case voltage change divided by the total temperature range.
  - Regulation is measured at constant junction temperature using low duty cycle pulse testing. Parts are tested for load regulation in the load range from 0.1mA to 150mA. Changes in output voltage due to heating effects are covered by the thermal regulation specification.
  - Dropout voltage is defined as the input to output differential at which the output voltage drops 1% ( $T_J = +25^\circ C$ ) or 2% ( $-40^\circ C \leq T_J \leq +125^\circ C$ ) below its nominal value measured at 1V differential.
  - Ground pin current is the regulator quiescent current plus pass transistor base current. The total current drawn from the supply is the sum of the load current plus the ground pin current.



**AP2202-2.6 Electrical Characteristics** (@ $V_{IN} = 3.6V$ ,  $I_{OUT} = 100\mu A$ ,  $C_{IN} = 1.0\mu F$ ,  $C_{OUT} = 2.2\mu F$ ,  $V_{EN} \geq 2.0V$ ,  $T_J = +25^\circ C$ , **Bold** typeface applies over  $-40^\circ C \leq T_J \leq +125^\circ C$  (Note 6), unless otherwise specified.)

Symbol	Parameter	Conditions	Min	Typ	Max	Unit
$\Delta V_{OUT}/V_{OUT}$	Output Voltage Accuracy	Variation from specified $V_{OUT}$	-1	—	1	%
			<b>-2</b>	—	<b>2</b>	
$\Delta V_{OUT}/\Delta T$	Output Voltage Temperature Coefficient (Note 7)	—	—	<b>120</b>	—	$\mu V/^\circ C$
$(\Delta V_{OUT}/V_{OUT})/\Delta T$		—	—	<b>46</b>	—	ppm/ $^\circ C$
$V_{RLINE}$	Line Regulation	$V_{IN} = 3.6V$ to $13.2V$	—	1	3	mV
			—	—	<b>13</b>	
$V_{RLOAD}$	Load Regulation (Note 8)	$I_{OUT} = 0.1mA$ to $150mA$	—	1	6	mV
			—	—	<b>14</b>	
$V_{DROP}$	Dropout Voltage (Note 9)	$I_{OUT} = 100\mu A$	—	15	50	mV
			—	—	<b>70</b>	
		$I_{OUT} = 50mA$	—	110	150	
			—	—	<b>230</b>	
		$I_{OUT} = 100mA$	—	140	250	
			—	—	<b>300</b>	
$I_{OUT} = 150mA$	—	165	275			
	—	—	<b>350</b>			
$I_{STD}$	Standby Current	$V_{EN} \leq 0.4V$ (shutdown)	—	0.01	1	$\mu A$
		$V_{EN} \leq 0.18V$ (shutdown)	—	—	<b>5</b>	
$I_{GND}$	Ground Pin Current (Note 10)	$V_{EN} \geq 2.0V$ , $I_{OUT} = 0\mu A$	—	95	130	$\mu A$
			—	—	<b>150</b>	
		$V_{EN} \geq 2.0V$ , $I_{OUT} = 100\mu A$	—	98	140	
			—	—	<b>160</b>	
		$V_{EN} \geq 2.0V$ , $I_{OUT} = 50mA$	—	350	600	
			—	—	<b>800</b>	
$V_{EN} \geq 2.0V$ , $I_{OUT} = 100mA$	—	600	1000			
	—	—	<b>1500</b>			
$V_{EN} \geq 2.0V$ , $I_{OUT} = 150mA$	—	1300	1900			
	—	—	<b>2500</b>			
PSRR	Ripple Rejection	Frequency = 100Hz, $I_{OUT} = 100\mu A$	—	75	—	dB
$I_{LIMIT}$	Current Limit	$V_{OUT} = 0V$	—	<b>320</b>	550	mA
$e_{no}$	Output Noise	$I_{OUT} = 50mA$ , $C_{OUT} = 2.2\mu F$ , 100pF from BYP to GND	—	260	—	$nV/\sqrt{Hz}$

**AP2202-2.6 Electrical Characteristics** (Cont.) (@ $V_{IN} = 3.6V$ ,  $I_{OUT} = 100\mu A$ ,  $C_{IN} = 1.0\mu F$ ,  $C_{OUT} = 2.2\mu F$ ,  $V_{EN} \geq 2.0V$ ,  $T_J = +25^\circ C$ , **Bold** typeface applies over  $-40^\circ C \leq T_J \leq +125^\circ C$  (Note 6), unless otherwise specified.)

Symbol	Parameter	Conditions	Min	Typ	Max	Unit
$V_{IL}$	Enable Input Logic-Low Voltage	Regulator Shutdown	—	—	0.4	V
			—	—	<b>0.18</b>	
$V_{IH}$	Enable Input Logic-High Voltage	Regulator Enabled	<b>2.0</b>	—	—	V
$I_{IL}$	Enable Input Logic-Low Current	$V_{IL} \leq 0.4V$	—	0.01	1	$\mu A$
		$V_{IL} \leq 0.18V$	—	—	<b>2</b>	
$I_{IH}$	Enable Input Logic-High Current	$V_{IH} \geq 2.0V$	—	5	20	$\mu A$
		$V_{IH} \geq 2.0V$	—	—	<b>25</b>	
$\theta_{JC}$	Thermal Resistance	SOT-23-5	—	63.4	—	$^\circ C/W$
		SOT-89	—	50	—	

- Notes:
- Specifications in bold type are limited to  $-40^\circ C \leq T_J \leq +125^\circ C$ . Limits over temperature are guaranteed by design, but not tested in production.
  - Output voltage temperature coefficient is defined as the worst case voltage change divided by the total temperature range.
  - Regulation is measured at constant junction temperature using low duty cycle pulse testing. Parts are tested for load regulation in the load range from 0.1mA to 150mA. Changes in output voltage due to heating effects are covered by the thermal regulation specification.
  - Dropout voltage is defined as the input to output differential at which the output voltage drops 1% ( $T_J = +25^\circ C$ ) or 2% ( $-40^\circ C \leq T_J \leq +125^\circ C$ ) below its nominal value measured at 1V differential.
  - Ground pin current is the regulator quiescent current plus pass transistor base current. The total current drawn from the supply is the sum of the load current plus the ground pin current.

**AP2202-2.8 Electrical Characteristics** (@ $V_{IN} = 3.8V$ ,  $I_{OUT} = 100\mu A$ ,  $C_{IN} = 1.0\mu F$ ,  $C_{OUT} = 2.2\mu F$ ,  $V_{EN} \geq 2.0V$ ,  $T_J = +25^\circ C$ , **Bold** typeface applies over  $-40^\circ C \leq T_J \leq +125^\circ C$  (Note 6), unless otherwise specified.)

Symbol	Parameter	Conditions	Min	Typ	Max	Unit
$\Delta V_{OUT}/V_{OUT}$	Output Voltage Accuracy	Variation from specified $V_{OUT}$	-1	—	1	%
			<b>-2</b>	—	<b>2</b>	
$\Delta V_{OUT}/\Delta T$	Output Voltage Temperature Coefficient (Note 7)	—	—	<b>120</b>	—	$\mu V/^\circ C$
$(\Delta V_{OUT}/V_{OUT})/\Delta T$		—	—	<b>42.8</b>	—	ppm/ $^\circ C$
$V_{RLINE}$	Line Regulation	$V_{IN} = 3.8V$ to $13.2V$	—	1	4	mV
			—	—	<b>14</b>	
$V_{RLOAD}$	Load Regulation (Note 8)	$I_{OUT} = 0.1mA$ to $150mA$	—	1	6	mV
			—	—	<b>14</b>	
$V_{DROP}$	Dropout Voltage (Note 9)	$I_{OUT} = 100\mu A$	—	15	50	mV
			—	—	<b>70</b>	
		$I_{OUT} = 50mA$	—	110	150	
			—	—	<b>230</b>	
		$I_{OUT} = 100mA$	—	140	250	
			—	—	<b>300</b>	
$I_{OUT} = 150mA$	—	165	275			
	—	—	<b>350</b>			
$I_{STD}$	Standby Current	$V_{EN} \leq 0.4V$ (shutdown)	—	0.01	1	$\mu A$
		$V_{EN} \leq 0.18V$ (shutdown)	—	—	<b>5</b>	
$I_{GND}$	Ground Pin Current (Note 10)	$V_{EN} \geq 2.0V$ , $I_{OUT} = 0\mu A$	—	95	130	$\mu A$
			—	—	<b>150</b>	
		$V_{EN} \geq 2.0V$ , $I_{OUT} = 100\mu A$	—	98	140	
			—	—	<b>160</b>	
		$V_{EN} \geq 2.0V$ , $I_{OUT} = 50mA$	—	350	600	
			—	—	<b>800</b>	
$V_{EN} \geq 2.0V$ , $I_{OUT} = 100mA$	—	600	1000			
	—	—	<b>1500</b>			
$V_{EN} \geq 2.0V$ , $I_{OUT} = 150mA$	—	1300	1900			
	—	—	<b>2500</b>			
PSRR	Ripple Rejection	Frequency = 100Hz, $I_{OUT} = 100\mu A$	—	75	—	dB
$I_{LIMIT}$	Current Limit	$V_{OUT} = 0V$	—	<b>320</b>	550	mA
$e_{no}$	Output Noise	$I_{OUT} = 50mA$ , $C_{OUT} = 2.2\mu F$ , 100pF from BYP to GND	—	260	—	$nV/\sqrt{Hz}$

**AP2202-2.8 Electrical Characteristics** (Cont.) (@ $V_{IN} = 3.8V$ ,  $I_{OUT} = 100\mu A$ ,  $C_{IN} = 1.0\mu F$ ,  $C_{OUT} = 2.2\mu F$ ,  $V_{EN} \geq 2.0V$ ,  $T_J = +25^\circ C$ , **Bold** typeface applies over  $-40^\circ C \leq T_J \leq +125^\circ C$  (Note 6), unless otherwise specified.)

Symbol	Parameter	Conditions	Min	Typ	Max	Unit
$V_{IL}$	Enable Input Logic-Low Voltage	Regulator Shutdown	—	—	0.4	V
			—	—	<b>0.18</b>	
$V_{IH}$	Enable Input Logic-High Voltage	Regulator Enabled	<b>2.0</b>	—	—	V
$I_{IL}$	Enable Input Logic-Low Current	$V_{IL} \leq 0.4V$	—	0.01	1	$\mu A$
		$V_{IL} \leq 0.18V$	—	—	<b>2</b>	
$I_{IH}$	Enable Input Logic-High Current	$V_{IH} \geq 2.0V$	—	5	20	$\mu A$
		$V_{IH} \geq 2.0V$	—	—	<b>25</b>	
$\theta_{JC}$	Thermal Resistance	SOT-23-5	—	63.4	—	$^\circ C/W$
		SOT-89	—	50	—	

- Notes:
6. Specifications in bold type are limited to  $-40^\circ C \leq T_J \leq +125^\circ C$ . Limits over temperature are guaranteed by design, but not tested in production.
  7. Output voltage temperature coefficient is defined as the worst case voltage change divided by the total temperature range.
  8. Regulation is measured at constant junction temperature using low duty cycle pulse testing. Parts are tested for load regulation in the load range from 0.1mA to 150mA. Changes in output voltage due to heating effects are covered by the thermal regulation specification.
  9. Dropout voltage is defined as the input to output differential at which the output voltage drops 1% ( $T_J = +25^\circ C$ ) or 2% ( $-40^\circ C \leq T_J \leq +125^\circ C$ ) below its nominal value measured at 1V differential.
  10. Ground pin current is the regulator quiescent current plus pass transistor base current. The total current drawn from the supply is the sum of the load current plus the ground pin current.

**AP2202-3.0 Electrical Characteristics** (@ $V_{IN} = 4V$ ,  $I_{OUT} = 100\mu A$ ,  $C_{IN} = 1.0\mu F$ ,  $C_{OUT} = 2.2\mu F$ ,  $V_{EN} \geq 2.0V$ ,  $T_J = +25^\circ C$ , **Bold** typeface applies over  $-40^\circ C \leq T_J \leq +125^\circ C$  (Note 6), unless otherwise specified.)

Symbol	Parameter	Conditions	Min	Typ	Max	Unit
$\Delta V_{OUT}/V_{OUT}$	Output Voltage Accuracy	Variation from specified $V_{OUT}$	-1	—	1	%
			<b>-2</b>	—	<b>2</b>	
$\Delta V_{OUT}/\Delta T$	Output Voltage Temperature	—	—	<b>120</b>	—	$\mu V/^\circ C$
$(\Delta V_{OUT}/V_{OUT})/\Delta T$	Coefficient (Note 7)	—	—	<b>40</b>	—	ppm/ $^\circ C$
$V_{RLINE}$	Line Regulation	$V_{IN} = 4V$ to $13.2V$	—	1	4	mV
			—	—	<b>14</b>	
$V_{RLOAD}$	Load Regulation (Note 8)	$I_{OUT} = 0.1mA$ to $150mA$	—	1	7	mV
			—	—	<b>15</b>	
$V_{DROP}$	Dropout Voltage (Note 9)	$I_{OUT} = 100\mu A$	—	15	50	mV
			—	—	<b>70</b>	
		$I_{OUT} = 50mA$	—	110	150	
			—	—	<b>230</b>	
		$I_{OUT} = 100mA$	—	140	250	
			—	—	<b>300</b>	
$I_{OUT} = 150mA$	—	165	275			
	—	—	<b>350</b>			
$I_{STD}$	Standby Current	$V_{EN} \leq 0.4V$ (shutdown)	—	0.01	1	$\mu A$
		$V_{EN} \leq 0.18V$ (shutdown)	—	—	<b>5</b>	
$I_{GND}$	Ground Pin Current (Note 10)	$V_{EN} \geq 2.0V$ , $I_{OUT} = 0\mu A$	—	95	130	$\mu A$
			—	—	<b>150</b>	
		$V_{EN} \geq 2.0V$ , $I_{OUT} = 100\mu A$	—	98	140	
			—	—	<b>160</b>	
		$V_{EN} \geq 2.0V$ , $I_{OUT} = 50mA$	—	350	600	
			—	—	<b>800</b>	
$V_{EN} \geq 2.0V$ , $I_{OUT} = 100mA$	—	600	1000			
	—	—	<b>1500</b>			
$V_{EN} \geq 2.0V$ , $I_{OUT} = 150mA$	—	1300	1900			
	—	—	<b>2500</b>			
PSRR	Ripple Rejection	Frequency = 100Hz, $I_{OUT} = 100\mu A$	—	75	—	dB
$I_{LIMIT}$	Current Limit	$V_{OUT} = 0V$	—	<b>320</b>	550	mA
$e_{no}$	Output Noise	$I_{OUT} = 50mA$ , $C_{OUT} = 2.2\mu F$ , 100pF from BYP to GND	—	260	—	$nV/\sqrt{Hz}$

**AP2202-3.0 Electrical Characteristics** (Cont.) (@ $V_{IN} = 4V$ ,  $I_{OUT} = 100\mu A$ ,  $C_{IN} = 1.0\mu F$ ,  $C_{OUT} = 2.2\mu F$ ,  $V_{EN} \geq 2.0V$ ,  $T_J = +25^\circ C$ , **Bold** typeface applies over  $-40^\circ C \leq T_J \leq +125^\circ C$  (Note 6), unless otherwise specified.)

Symbol	Parameter	Conditions	Min	Typ	Max	Unit
$V_{IL}$	Enable Input Logic-Low Voltage	Regulator Shutdown	—	—	0.4	V
			—	—	<b>0.18</b>	
$V_{IH}$	Enable Input Logic-High Voltage	Regulator Enabled	<b>2.0</b>	—	—	V
$I_{IL}$	Enable Input Logic-Low Current	$V_{IL} \leq 0.4V$	—	0.01	1	$\mu A$
		$V_{IL} \leq 0.18V$	—	—	<b>2</b>	
$I_{IH}$	Enable Input Logic-High Current	$V_{IH} \geq 2.0V$	—	5	20	$\mu A$
		$V_{IH} \geq 2.0V$	—	—	<b>25</b>	
$\theta_{JC}$	Thermal Resistance	SOT-23-5	—	63.4	—	$^\circ C/W$
		SOT-89	—	50	—	

- Notes:
- Specifications in bold type are limited to  $-40^\circ C \leq T_J \leq +125^\circ C$ . Limits over temperature are guaranteed by design, but not tested in production.
  - Output voltage temperature coefficient is defined as the worst case voltage change divided by the total temperature range.
  - Regulation is measured at constant junction temperature using low duty cycle pulse testing. Parts are tested for load regulation in the load range from 0.1mA to 150mA. Changes in output voltage due to heating effects are covered by the thermal regulation specification.
  - Dropout voltage is defined as the input to output differential at which the output voltage drops 1% ( $T_J = +25^\circ C$ ) or 2% ( $-40^\circ C \leq T_J \leq +125^\circ C$ ) below its nominal value measured at 1V differential.
  - Ground pin current is the regulator quiescent current plus pass transistor base current. The total current drawn from the supply is the sum of the load current plus the ground pin current.

**AP2202-3.3 Electrical Characteristics** (@ $V_{IN} = 4.3V$ ,  $I_{OUT} = 100\mu A$ ,  $C_{IN} = 1.0\mu F$ ,  $C_{OUT} = 2.2\mu F$ ,  $V_{EN} \geq 2.0V$ ,  $T_J = +25^\circ C$ , **Bold** typeface applies over  $-40^\circ C \leq T_J \leq +125^\circ C$  (Note 6), unless otherwise specified.)

Symbol	Parameter	Conditions	Min	Typ	Max	Unit
$\Delta V_{OUT}/V_{OUT}$	Output Voltage Accuracy	Variation from specified $V_{OUT}$	-1	—	1	%
			<b>-2</b>	—	<b>2</b>	
$\Delta V_{OUT}/\Delta T$	Output Voltage Temperature	—	—	<b>120</b>	—	$\mu V/^\circ C$
$(\Delta V_{OUT}/V_{OUT})/\Delta T$	Coefficient (Note 7)	—	—	<b>36.3</b>	—	ppm/ $^\circ C$
$V_{RLINE}$	Line Regulation	$V_{IN} = 4.3V$ to $13.2V$	—	1	5	mV
			—	—	<b>15</b>	
$V_{RLOAD}$	Load Regulation (Note 8)	$I_{OUT} = 0.1mA$ to $150mA$	—	1	8	mV
			—	—	<b>17</b>	
$V_{DROP}$	Dropout Voltage (Note 9)	$I_{OUT} = 100\mu A$	—	15	50	mV
			—	—	<b>70</b>	
		$I_{OUT} = 50mA$	—	110	150	
			—	—	<b>230</b>	
		$I_{OUT} = 100mA$	—	140	250	
			—	—	<b>300</b>	
$I_{OUT} = 150mA$	—	165	275			
	—	—	<b>350</b>			
$I_{STD}$	Standby Current	$V_{EN} \leq 0.4V$ (shutdown)	—	0.01	1	$\mu A$
		$V_{EN} \leq 0.18V$ (shutdown)	—	—	<b>5</b>	
$I_{GND}$	Ground Pin Current (Note 10)	$V_{EN} \geq 2.0V$ , $I_{OUT} = 0\mu A$	—	95	130	$\mu A$
			—	—	<b>150</b>	
		$V_{EN} \geq 2.0V$ , $I_{OUT} = 100\mu A$	—	98	140	
			—	—	<b>160</b>	
		$V_{EN} \geq 2.0V$ , $I_{OUT} = 50mA$	—	350	600	
			—	—	<b>800</b>	
$V_{EN} \geq 2.0V$ , $I_{OUT} = 100mA$	—	600	1000			
	—	—	<b>1500</b>			
$V_{EN} \geq 2.0V$ , $I_{OUT} = 150mA$	—	1300	1900			
	—	—	<b>2500</b>			
PSRR	Ripple Rejection	Frequency = 100Hz, $I_{OUT} = 100\mu A$	—	75	—	dB
$I_{LIMIT}$	Current Limit	$V_{OUT} = 0V$	—	<b>320</b>	550	mA
$e_{no}$	Output Noise	$I_{OUT} = 50mA$ , $C_{OUT} = 2.2\mu F$ , 100pF from BYP to GND	—	260	—	$nV/\sqrt{Hz}$

**AP2202-3.3 Electrical Characteristics** (Cont.) (@ $V_{IN} = 4.3V$ ,  $I_{OUT} = 100\mu A$ ,  $C_{IN} = 1.0\mu F$ ,  $C_{OUT} = 2.2\mu F$ ,  $V_{EN} \geq 2.0V$ ,  $T_J = +25^\circ C$ , **Bold** typeface applies over  $-40^\circ C \leq T_J \leq +125^\circ C$  (Note 6), unless otherwise specified.)

Symbol	Parameter	Conditions	Min	Typ	Max	Unit
$V_{IL}$	Enable Input Logic-Low Voltage	Regulator Shutdown	—	—	0.4	V
			—	—	<b>0.18</b>	
$V_{IH}$	Enable Input Logic-High Voltage	Regulator Enabled	<b>2.0</b>	—	—	V
$I_{IL}$	Enable Input Logic-Low Current	$V_{IL} \leq 0.4V$	—	0.01	1	$\mu A$
		$V_{IL} \leq 0.18V$	—	—	<b>2</b>	
$I_{IH}$	Enable Input Logic-High Current	$V_{IH} \geq 2.0V$	—	5	20	$\mu A$
		$V_{IH} \geq 2.0V$	—	—	<b>25</b>	
$\theta_{JC}$	Thermal Resistance	SOT-23-5	—	63.4	—	$^\circ C/W$
		SOT-89	—	50	—	

- Notes:
- Specifications in bold type are limited to  $-40^\circ C \leq T_J \leq +125^\circ C$ . Limits over temperature are guaranteed by design, but not tested in production.
  - Output voltage temperature coefficient is defined as the worst case voltage change divided by the total temperature range.
  - Regulation is measured at constant junction temperature using low duty cycle pulse testing. Parts are tested for load regulation in the load range from 0.1mA to 150mA. Changes in output voltage due to heating effects are covered by the thermal regulation specification.
  - Dropout voltage is defined as the input to output differential at which the output voltage drops 1% ( $T_J = +25^\circ C$ ) or 2% ( $-40^\circ C \leq T_J \leq +125^\circ C$ ) below its nominal value measured at 1V differential.
  - Ground pin current is the regulator quiescent current plus pass transistor base current. The total current drawn from the supply is the sum of the load current plus the ground pin current.



**Performance Characteristics**

**Output Voltage vs. Junction Temperature**

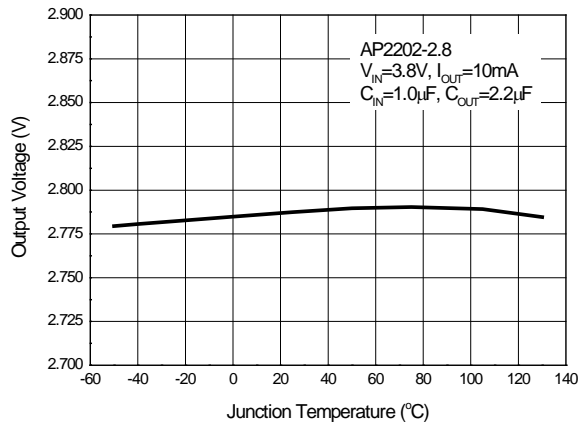

**Dropout Voltage vs. Junction Temperature**

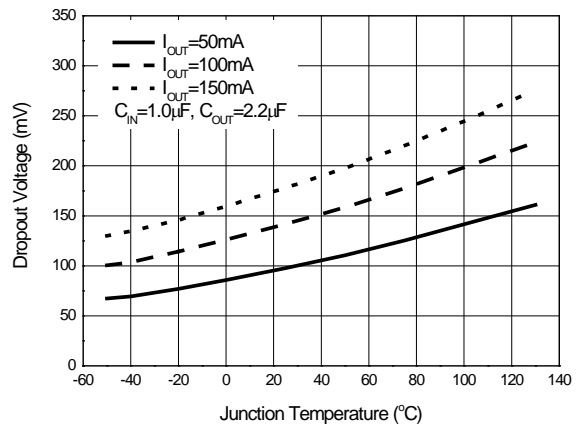

**Ground Pin Current vs. Output Current**

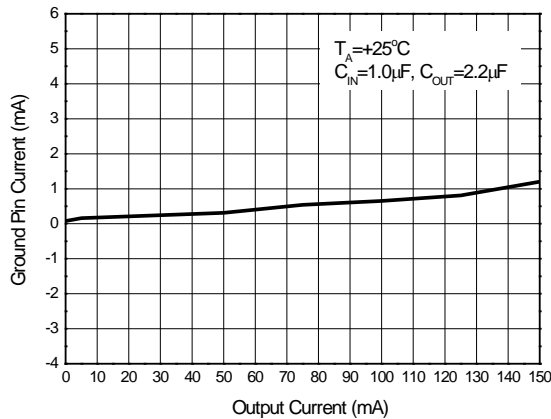

**Ground Pin Current vs. Junction Temperature**

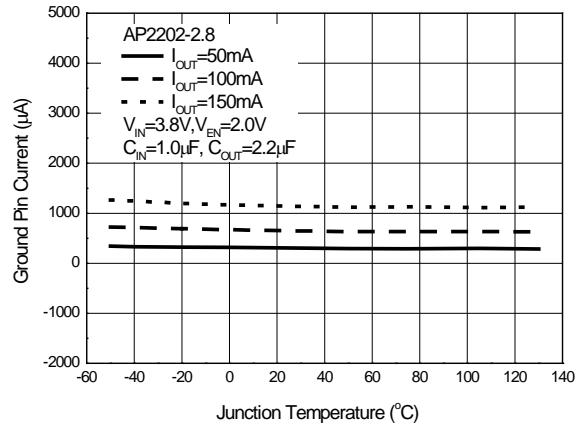

**Enable Current vs. Junction Temperature**

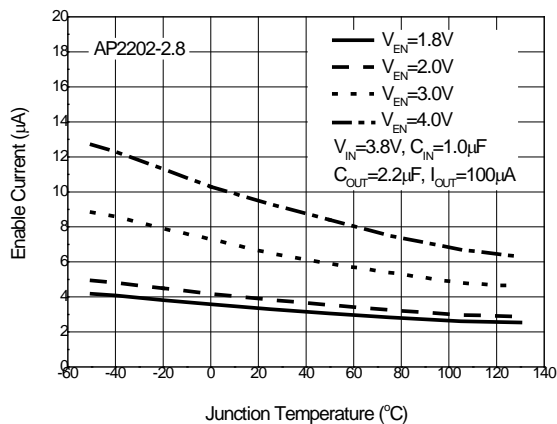

**Enable Voltage vs. Junction Temperature**

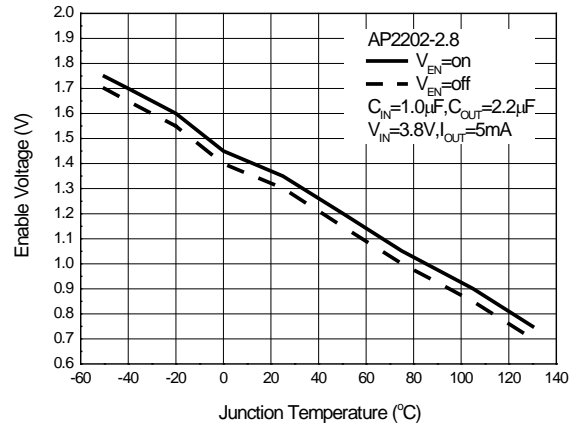

**Performance Characteristics (Cont.)**

**Noise vs. Bypass Capacitor**

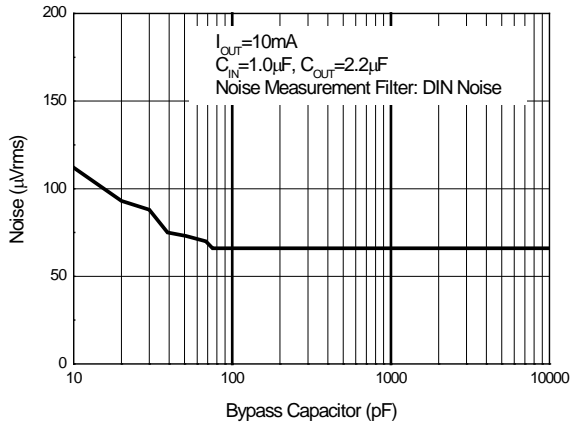

**Output Noise vs. Frequency**

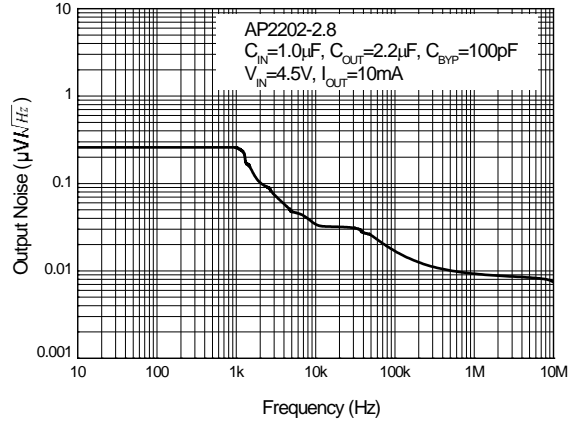

**Load Transient**

(Conditions:  $V_{IN}=3.8V$ ,  $C_{BYP}=100pF$ ,  $V_{EN}=2V$ ,  $I_{OUT}=5mA$  to  $50mA$ ,  $C_{IN}=1.0µF$ ,  $C_{OUT}=2.2µF$ )

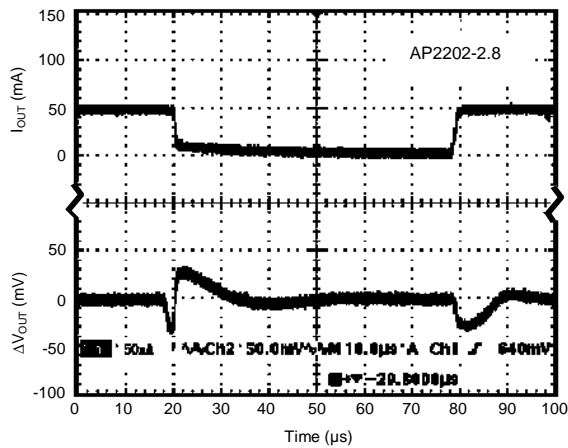

**Line Transient**

(Conditions:  $V_{IN}=3.8V$  to  $4.8V$ ,  $V_{EN}=2V$ ,  $I_{OUT}=100µA$ ,  $C_{BYP}=100pF$ ,  $C_{OUT}=10µF$ )

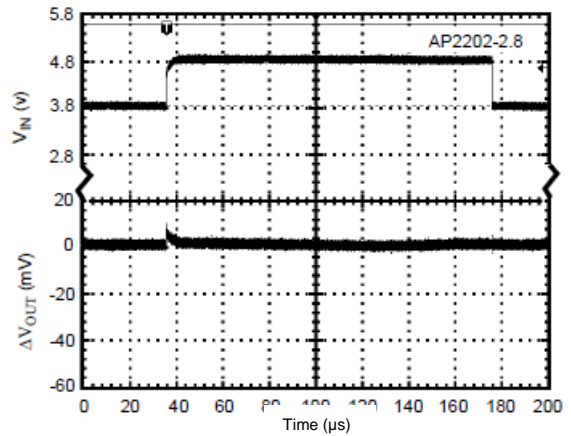

**$V_{EN(on)}$  vs.  $V_{OUT}$**

(Conditions:  $V_{EN}=0V$  to  $2V$ ,  $V_{IN}=3.8V$ ,  $I_{OUT}=30mA$ ,  $C_{BYP}=open$ ,  $C_{IN}=1.0µF$ ,  $C_{OUT}=2.2µF$ )

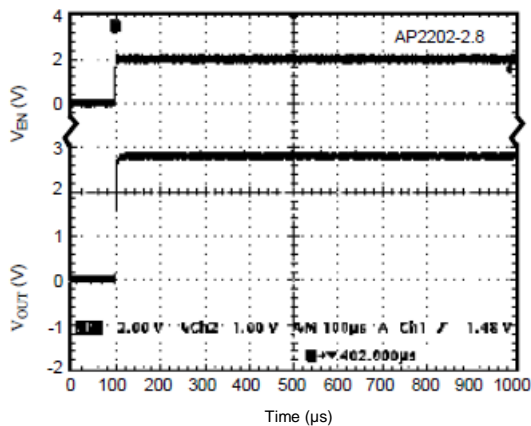

**PSRR vs. Frequency**

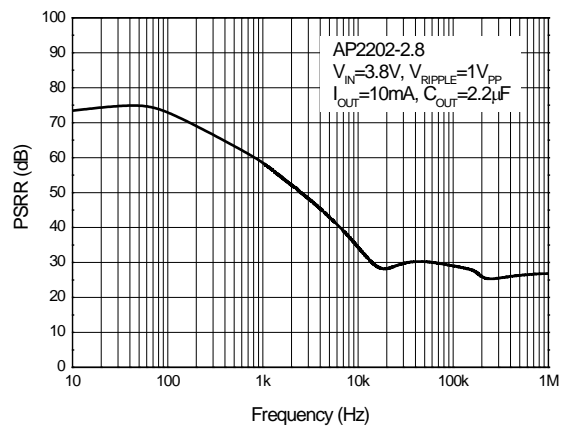

**Performance Characteristics (Cont.)**

**Power Dissipation vs. Ambient Temperature**

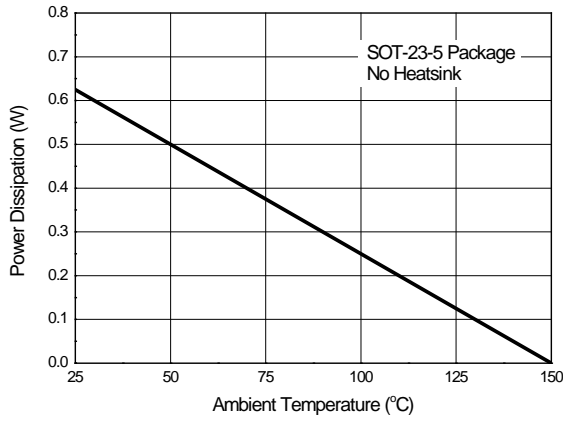

**Power Dissipation vs. Ambient Temperature**

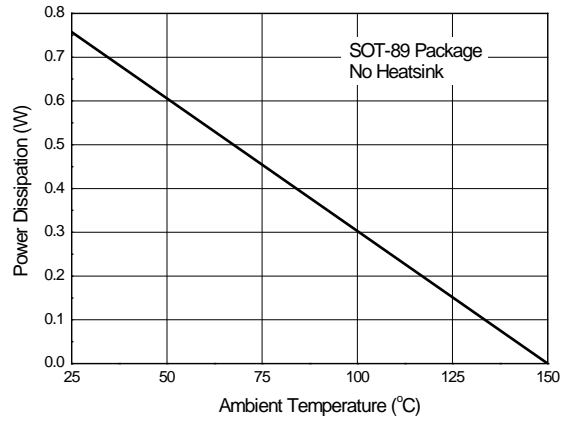

**ESR vs. Output Current**

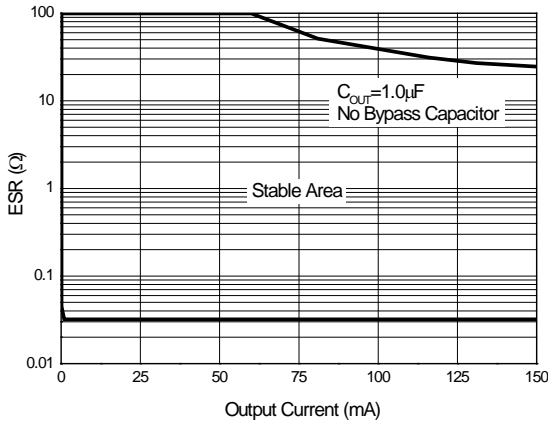

**ESR vs. Output Current**

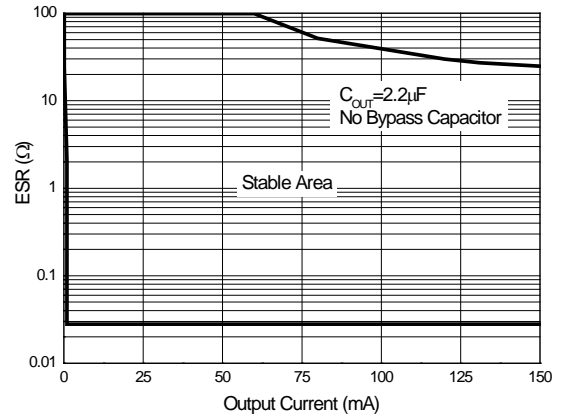

**ESR vs. Output Current**

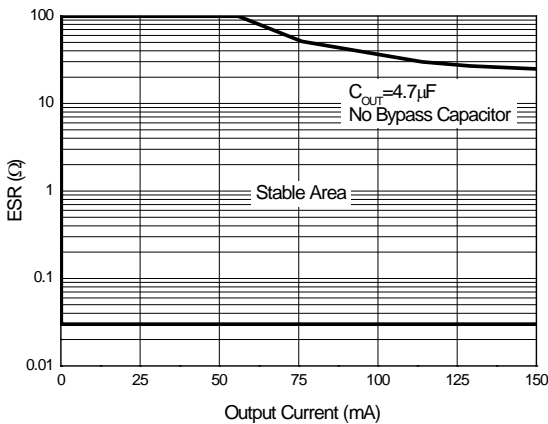

---

## Application Information

---

### Input Capacitor

A 1 $\mu$ F minimum capacitor is recommended to be placed between  $V_{IN}$  and GND.

### Output Capacitor

An output capacitor is required to prevent oscillation. A 1.0 $\mu$ F minimum is recommended when  $C_{BYP}$  is unused. A 2.2 $\mu$ F minimum is recommended when  $C_{BYP}$  is 100pF. The output capacitor may be increased to improve transient response.

### Noise Bypass Capacitor

A bypass capacitor is connected to the internal voltage reference. A 100pF capacitor connected from BYP to GND makes this reference quiet, resulting in a significant reduction in output noise, but the ESR stable area will be narrowed.

The start-up speed of the AP2202 is inversely proportional to the value of the reference bypass capacitor. In some cases, if output noise is not a major concern and rapid turn-on is necessary, omit  $C_{BYP}$  and leave BYP open.

### Power Dissipation

Thermal shutdown may take place if the maximum power dissipation is exceeded in application. Under all possible operating conditions, the junction temperature must be within the range specified under absolute maximum ratings to avoid thermal shutdown.

To determine if the power dissipated in the regulator reaches the maximum power dissipation (see Figure Power Dissipation vs. Ambient Temperature (SOT-23-5 package and SOT-89 package)), use:

$$T_J = P_D \cdot \theta_{JA} + T_A$$

$$P_D = (V_{IN} - V_{OUT}) \cdot I_{OUT} + V_{IN} \cdot I_{GND}$$

Where:  $T_J \leq T_{J(max)}$ ,  $T_{J(max)}$  is absolute maximum ratings for the junction temperature;  $V_{IN} \cdot I_{GND}$  can be ignored due to its small value.

$T_{J(max)}$  is +150°C,  $\theta_{JA}$  is 200°C/W for SOT-23-5 package and 165°C/W for SOT-89 package, no heatsink is required since the package alone will dissipate enough heat to satisfy these requirements unless the calculated value for power dissipation exceeds the limit.

Example: For 2.8V version packaged in SOT-23-5,  $I_{OUT} = 150\text{mA}$ ,  $T_A = +50^\circ\text{C}$ ,  $V_{IN(Max)}$  is:  
 $(150^\circ\text{C} - 50^\circ\text{C}) / (0.15\text{A} \cdot 200^\circ\text{C/W}) + 2.8\text{V} = 6.133\text{V}$

Therefore, for good performance, please make sure that input voltage is less than 6.133V without heatsink when  $T_A = +50^\circ\text{C}$ .

## Ordering Information

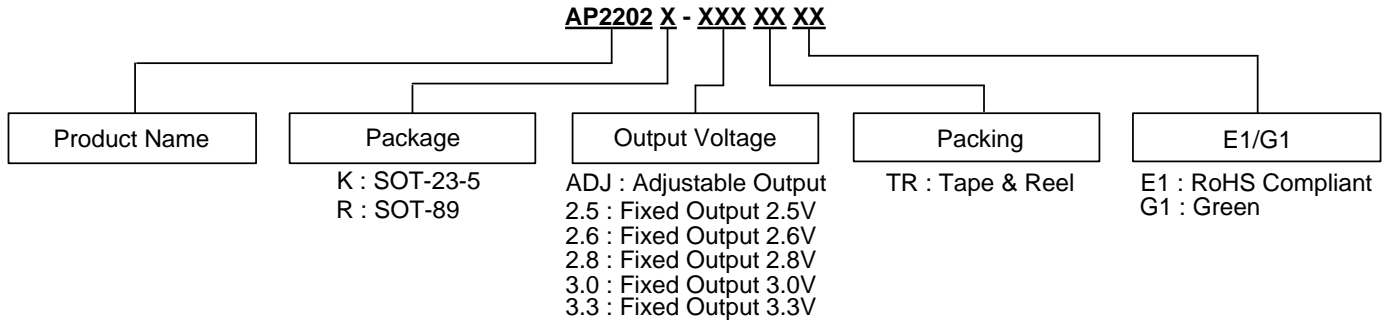

Package	Temperature Range	Part Number		Marking ID		Packing
		RoHS Compliant (Note 11)	Green	RoHS Compliant	Green	
SOT-23-5	-40 to +125°C	AP2202K-ADJTRE1	AP2202K-ADJTRG1	E2C	G2C	3k/Tape & Reel
		AP2202K-2.5TRE1	AP2202K-2.5TRG1	E2D	G2D	3k/Tape & Reel
		AP2202K-2.6TRE1	AP2202K-2.6TRG1 (Note 11)	E2E	G2E	3k/Tape & Reel
		AP2202K-2.8TRE1	AP2202K-2.8TRG1 (Note 11)	E2G	G2G	3k/Tape & Reel
		AP2202K-3.0TRE1	AP2202K-3.0TRG1	E2I	G2I	3k/Tape & Reel
		AP2202K-3.3TRE1	AP2202K-3.3TRG1	E2L	G2L	3k/Tape & Reel
SOT-89	-40 to +125°C	AP2202R-3.3TRE1	AP2202R-3.3TRG1	E22B	G22B	3k/Tape & Reel



Lead-Free



Lead-free Greer



Lead-Free



Lead-free Greer

Notes: 11. Not recommended for new design.

---

## Marking Information

---

(1) SOT-23-5

(Top View)

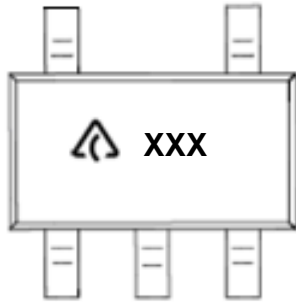

 : Logo  
XXX : Marking ID (See Ordering Information)

(2) SOT-89

(Top View)

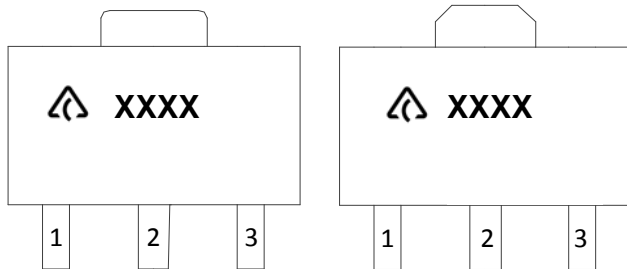

 : Logo  
XXXX : Marking ID (See Ordering Information)

**Package Outline Dimensions** (All dimensions in mm(inch).)

(1) Package Type: SOT-23-5

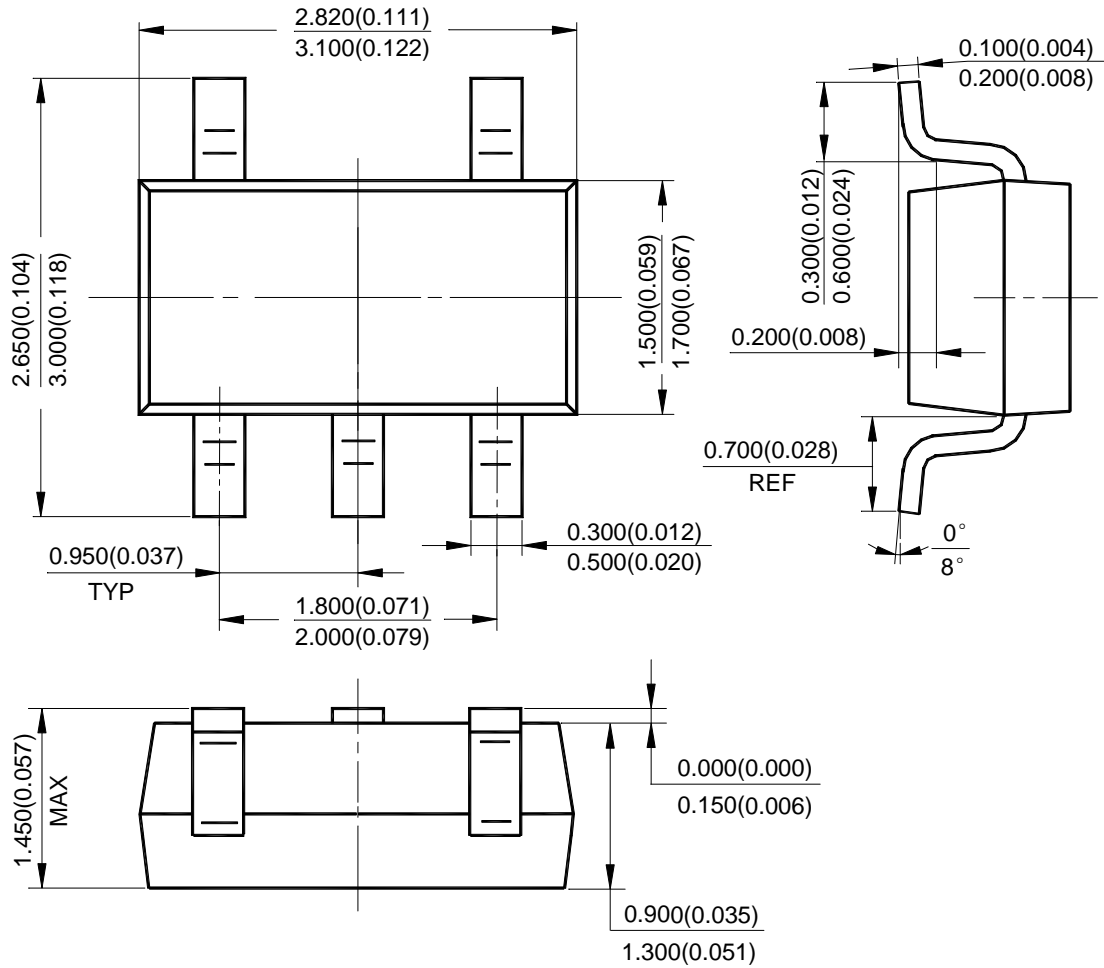

**Package Outline Dimensions** (Cont. All dimensions in mm(inch).)

(2) Package Type: SOT-89

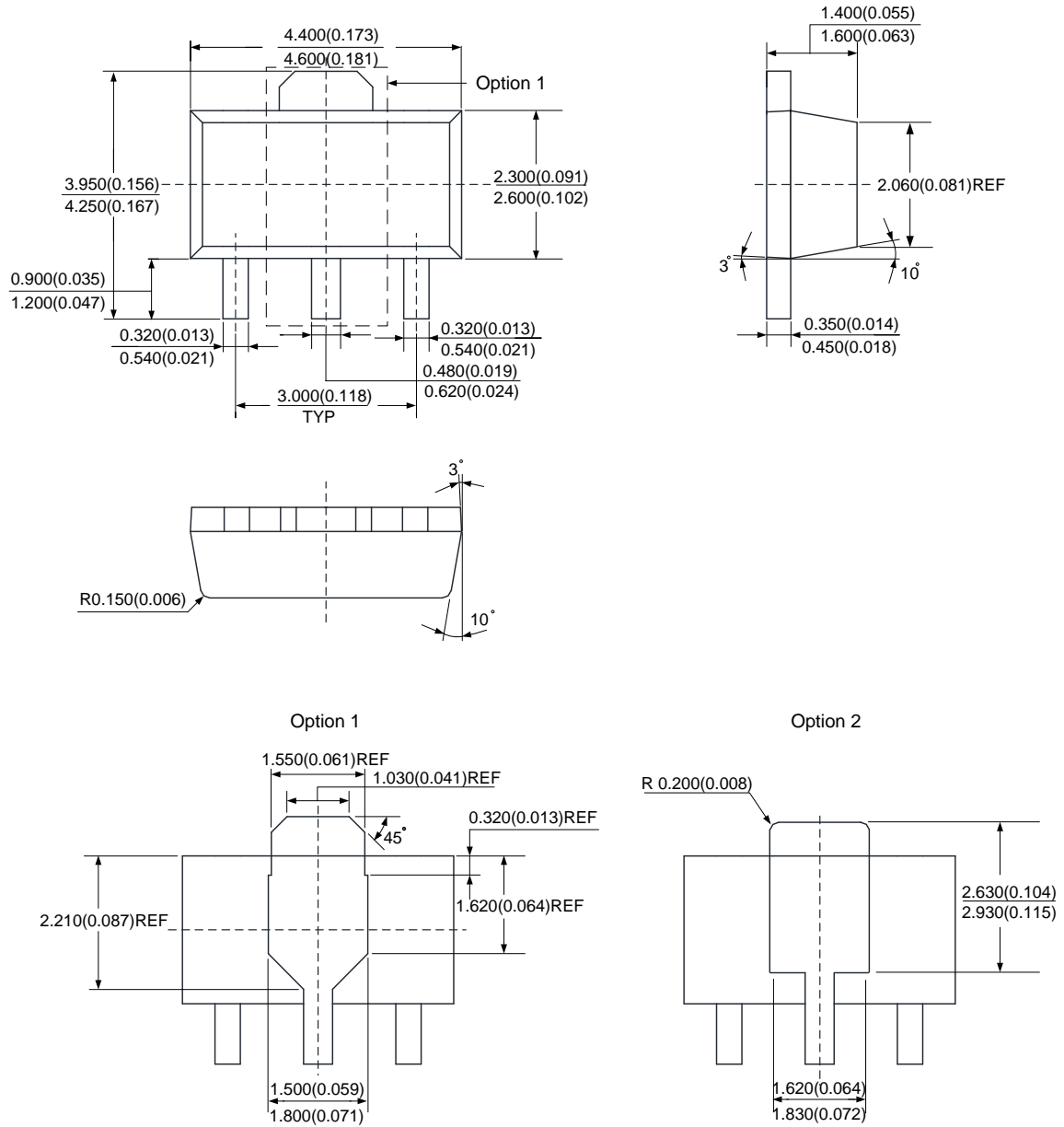



## Suggested Pad Layout

(1) Package Type: SOT-23-5

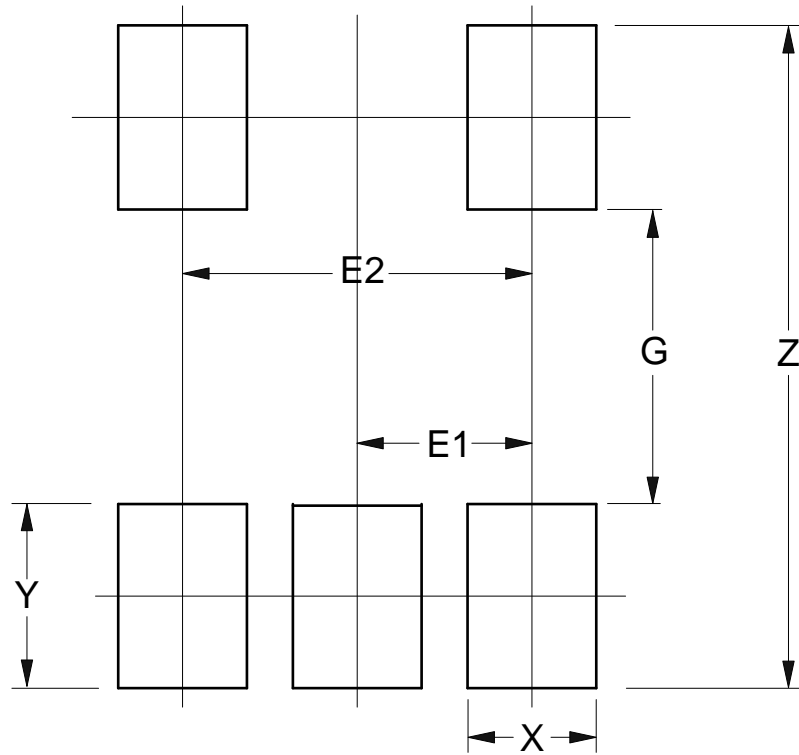

Dimensions	Z (mm)/(inch)	G (mm)/(inch)	X (mm)/(inch)	Y (mm)/(inch)	E1 (mm)/(inch)	E2 (mm)/(inch)
Value	3.600/0.142	1.600/0.063	0.700/0.028	1.000/0.039	0.950/0.037	1.900/0.075

**Suggested Pad Layout** (Cont.)

(2) Package Type: SOT-89

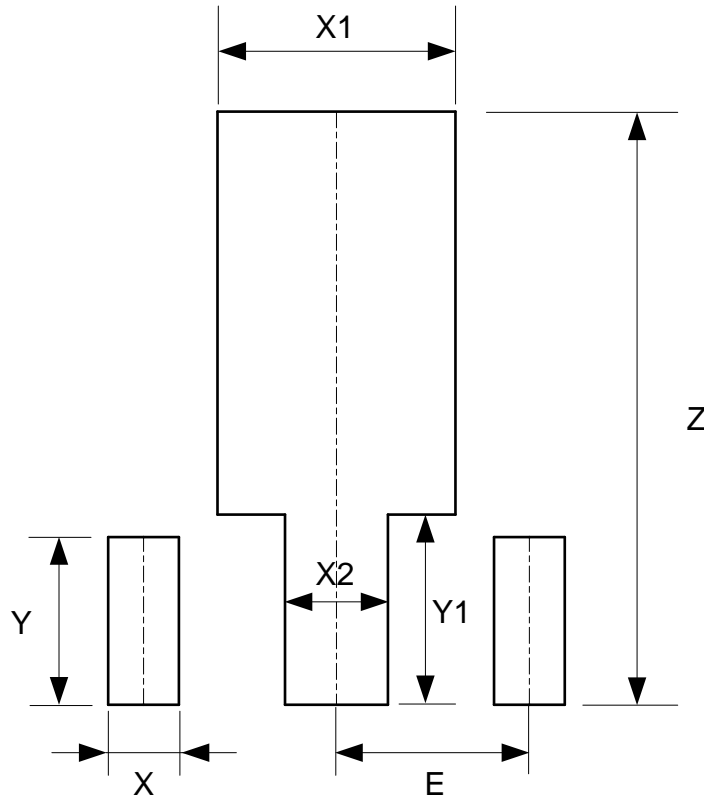

Dimensions	Z (mm)/(inch)	X (mm)/(inch)	X1 (mm)/(inch)	X2 (mm)/(inch)	Y (mm)/(inch)	Y1 (mm)/(inch)	E (mm)/(inch)
Value	4.600/0.181	0.550/0.022	1.850/0.073	0.800/0.031	1.300/0.051	1.475/0.058	1.500/0.059

#### IMPORTANT NOTICE

DIODES INCORPORATED MAKES NO WARRANTY OF ANY KIND, EXPRESS OR IMPLIED, WITH REGARDS TO THIS DOCUMENT, INCLUDING, BUT NOT LIMITED TO, THE IMPLIED WARRANTIES OF MERCHANTABILITY AND FITNESS FOR A PARTICULAR PURPOSE (AND THEIR EQUIVALENTS UNDER THE LAWS OF ANY JURISDICTION).

Diodes Incorporated and its subsidiaries reserve the right to make modifications, enhancements, improvements, corrections or other changes without further notice to this document and any product described herein. Diodes Incorporated does not assume any liability arising out of the application or use of this document or any product described herein; neither does Diodes Incorporated convey any license under its patent or trademark rights, nor the rights of others. Any Customer or user of this document or products described herein in such applications shall assume all risks of such use and will agree to hold Diodes Incorporated and all the companies whose products are represented on Diodes Incorporated website, harmless against all damages.

Diodes Incorporated does not warrant or accept any liability whatsoever in respect of any products purchased through unauthorized sales channel. Should Customers purchase or use Diodes Incorporated products for any unintended or unauthorized application, Customers shall indemnify and hold Diodes Incorporated and its representatives harmless against all claims, damages, expenses, and attorney fees arising out of, directly or indirectly, any claim of personal injury or death associated with such unintended or unauthorized application.

Products described herein may be covered by one or more United States, international or foreign patents pending. Product names and markings noted herein may also be covered by one or more United States, international or foreign trademarks.

This document is written in English but may be translated into multiple languages for reference. Only the English version of this document is the final and determinative format released by Diodes Incorporated.

#### LIFE SUPPORT

Diodes Incorporated products are specifically not authorized for use as critical components in life support devices or systems without the express written approval of the Chief Executive Officer of Diodes Incorporated. As used herein:

A. Life support devices or systems are devices or systems which:

1. are intended to implant into the body, or
2. support or sustain life and whose failure to perform when properly used in accordance with instructions for use provided in the labeling can be reasonably expected to result in significant injury to the user.

B. A critical component is any component in a life support device or system whose failure to perform can be reasonably expected to cause the failure of the life support device or to affect its safety or effectiveness.

Customers represent that they have all necessary expertise in the safety and regulatory ramifications of their life support devices or systems, and acknowledge and agree that they are solely responsible for all legal, regulatory and safety-related requirements concerning their products and any use of Diodes Incorporated products in such safety-critical, life support devices or systems, notwithstanding any devices- or systems-related information or support that may be provided by Diodes Incorporated. Further, Customers must fully indemnify Diodes Incorporated and its representatives against any damages arising out of the use of Diodes Incorporated products in such safety-critical, life support devices or systems.

Copyright © 2020, Diodes Incorporated

[www.diodes.com](http://www.diodes.com)