

THIS DRAWING IS UNPUBLISHED. RELEASED FOR PUBLICATION
 © COPYRIGHT - By - ALL RIGHTS RESERVED.

| LOC | DIST | REVISIONS | | | | | |
|-----|------|-----------|-----|---------------------------|---------|-----|------|
| | | P | LTR | DESCRIPTION | DATE | DWN | APVD |
| G | 14 | | W2 | REVISED PER ECO-11-004917 | 11MAR11 | RK | HMR |

- △ 1 FOR 9.53 [.375] MAX WIRE INSULATION DIA
- △ 2 SUPERSEDED BY 35653
- △ 3 MATERIAL: BODY; COPPER PER ASTM B152 INSULATION; NYLON COLOR; NATURAL
- △ 4 FINISH: BODY; TIN PL. PER ASTM B545

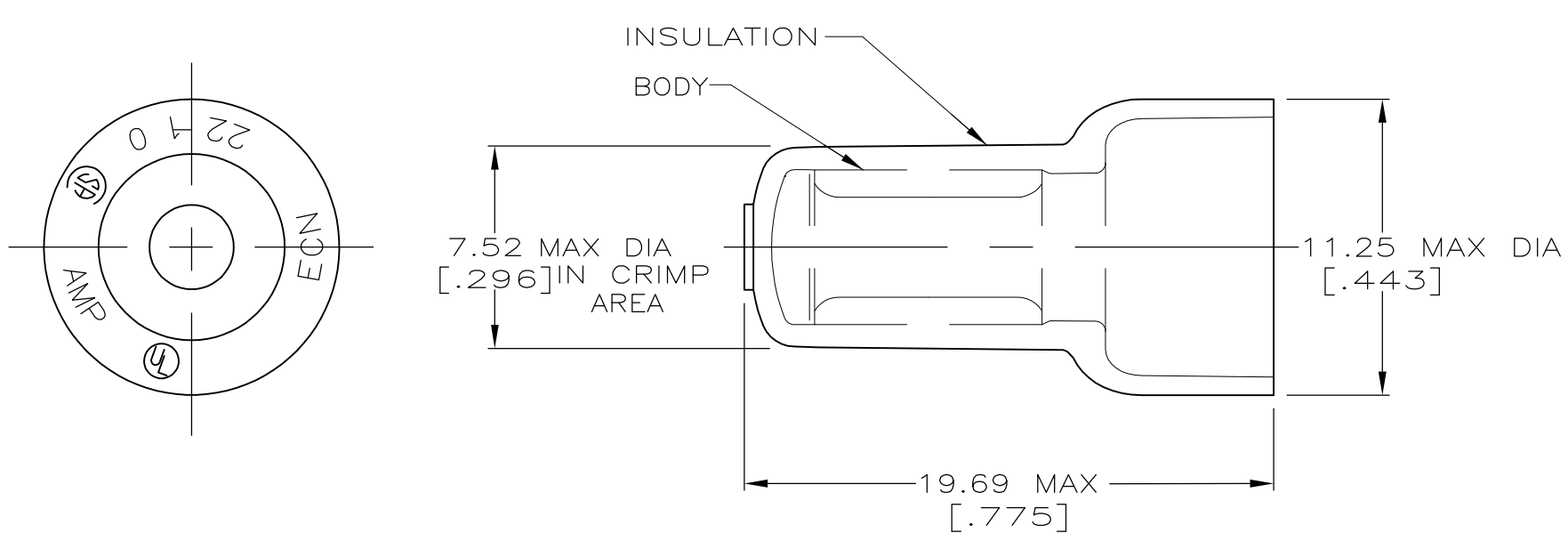

| | | |
|--------------------------------|--------------------------------|--------------------------------|
| AMP WIRE RANGE | Listed | LR7189 Certified |
| 22-10 AWG SOLID OR STRANDED | 22-10 AWG SOLID OR STRANDED | 22-10 AWG SOLID OR STRANDED |

| QTY | DESCRIPTION | PART NO |
|-------|--------------|---------------|
| 25 | LOOSE PC,BAG | 8-35653-5 |
| 5 | LOOSE PC,BLS | 8-35653-4 |
| 100 | LOOSE PC,BOX | 8-35653-1 |
| 10000 | SPECIAL PKG, | 2-35653-2 △ 2 |
| 1500 | TAPE MOUNTED | 2-35653-1 |
| 1000 | LOOSE PIECE | 35653 |
| | | |

| | | | | | | | | | |
|--|--|---|--|---|----------------------|-----------------|-----------|------------|----------------------------------|
| AMP INCORPORATED CUSTOMER SERVICE SYSTEMS | | MAX RECOMMENDED OPERATING TEMPERATURE: 105° C MAX | THIS DRAWING IS A CONTROLLED DOCUMENT. | | DWN G KRUPER 1/93 | TE Connectivity | | | |
| FOR ADDITIONAL PRODUCT INFORMATION OR COPIES OF DRAWINGS AND TECHNICAL DOCUMENTS | PRODUCT INFORMATION CENTER 1-800-522-6752 | VOLTAGE RATING: 300V MAX | DIMENSIONS: INCHES | TOLERANCES UNLESS OTHERWISE SPECIFIED: | CHK R HERSEY 1/93 | | | | NAME SPLICE, WIRE, CLOSED END |
| FOR APPLICATION TOOLING INFORMATION | TOOLING ASSISTANCE CENTER 1-800-722-1111 | CIRCULAR MIL AREA: 1.65-6.64mm² [3248-13100] SOLID OR STRANDED | | 0 PLC ± - 1 PLC ± - 2 PLC ± 0.20 [.008] 3 PLC ± - 4 PLC ± - ANGLES ± - | APVD M ELLIS 1/93 | PRODUCT SPEC | | | |
| FOR ORDER ENTRY | 1-800-526-5142 | THIS DRAWING IS A CONTROLLED DOCUMENT FOR AMP INCORPORATED. IT IS SUBJECT TO CHANGE AND THE CONTROLLING ENGINEERING ORGANIZATION SHOULD BE CONTACTED FOR THE LATEST REVISION. | MATERIAL △ 3 | FINISH △ 4 | APPLICATION SPEC | SIZE | CAGE CODE | DRAWING NO | RESTRICTED TO |
| | | | | | WEIGHT | A3 | 00779 | C-35653 | |
| | | | | | CUSTOMER DRAWING | | SCALE | SHEET | REV |
| | | | | | | | 4:1 | 1 OF 1 | W2 |