

Sep.1.2020 Copyright 2020 HIROSE ELECTRIC CO., LTD. All Rights Reserved.
In case of consideration for using Automotive equipment / device which demand high reliability, kindly contact our sales window correspondents.

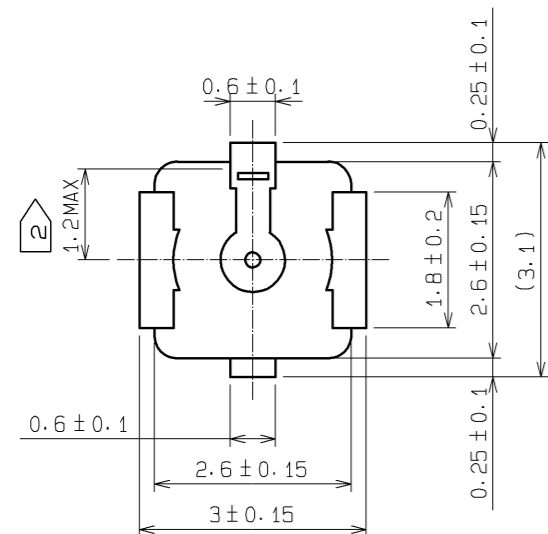

RECOMMENDED PCB LAYOUT
(MOUNTING SURFACE SIDE) (5:1)

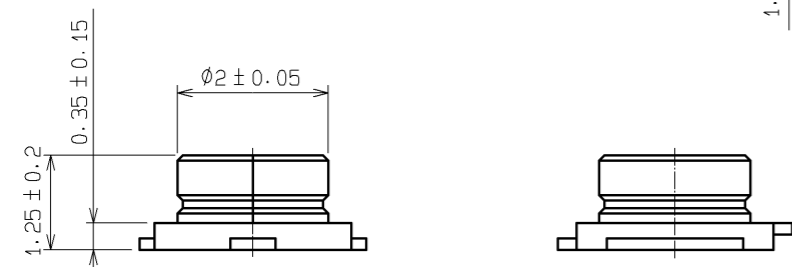
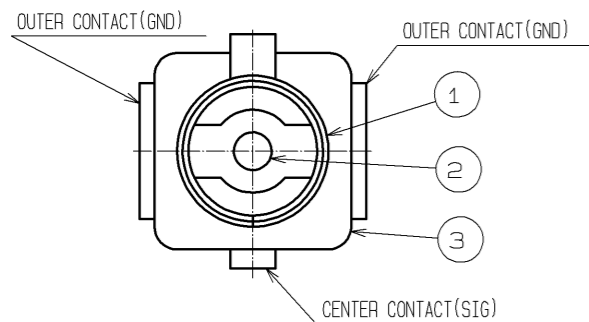
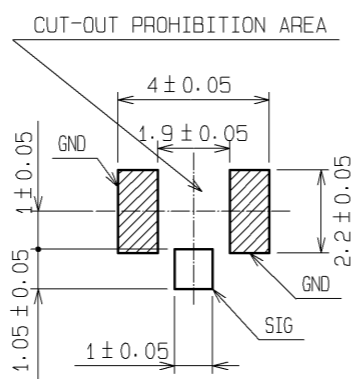

RECOMMENDED METAL MASK DIMENSIONS (5:1)
METAL MASK THICKNESS: 0.1mm/0.12mm

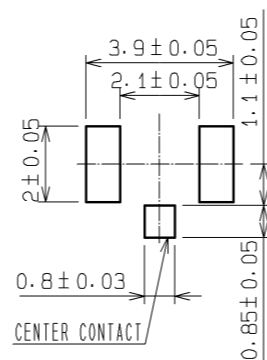

EMBOSSED TAPING DRAWING (4:1)

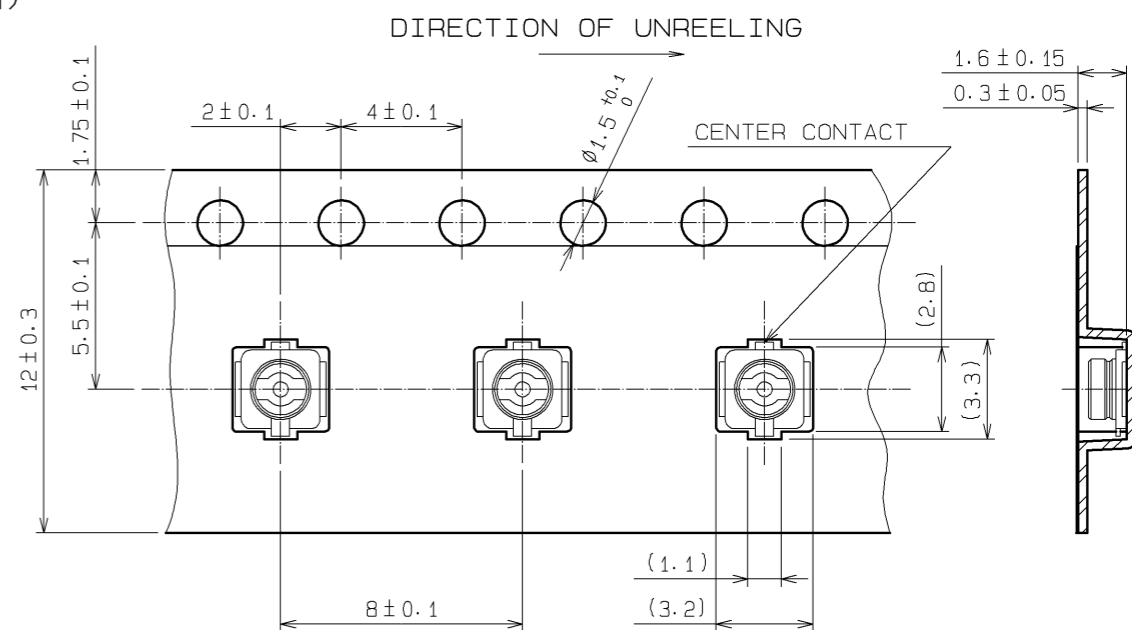

REEL DRAWING (SCALE FREE)

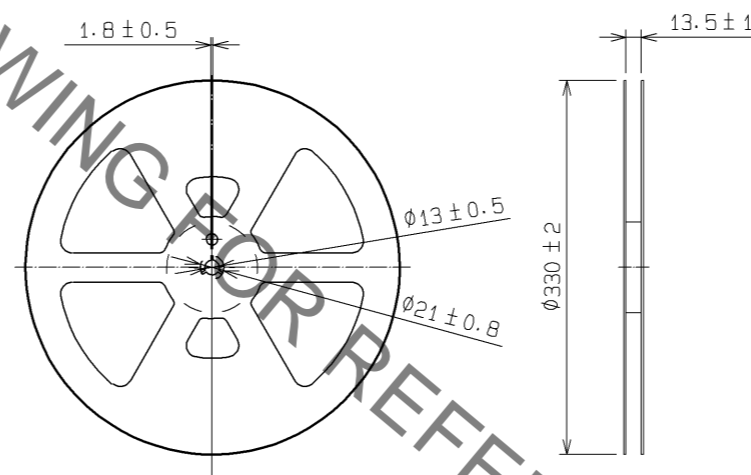

MATERIAL : PS (BLACK)

REFLOW TEMPERATURE PROFILE USING
LEAD-FREE SOLDER PASTE (REFERENCE)

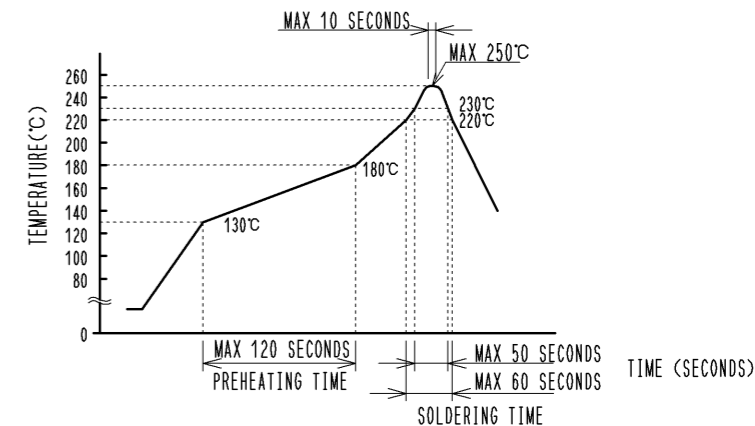

- 1) REFLOW TIME
REFLOW METHOD : IR REFLOW
NUMBER OF REFLOW CYCLES : 2 CYCLES MAX.
DURATION ABOVE 220 °C : 60 SEC. MAX.
DURATION ABOVE 230 °C : 50 SEC. MAX.
(PEAK TEMPERATURE : 250°C 10 SEC. MAX.)
- 2) PRE-HEAT TIME
PRE-HEAT TEMPERATURE(MIN) : 130 °C
PRE-HEAT TEMPERATURE(MAX) : 180 °C
PRE-HEAT TIME : 120 SEC. MAX.

THIS TEMPERATURE PROFILE IS PER THE CONDITIONS SHOWN ABOVE.
ADDITIONAL FACTORS, SUCH AS SOLDER PASTE TYPE,
PCB SIZE AND OTHER MOUNTED COMPONENTS COULD AFFECT THE PROFILE, THEREFORE,
A THOROUGH EVALUATION OF MOUNTING CONDITION IS REQUIRED PRIOR TO PRODUCTION.
TEMPERATURE IS MEASURED AT CONTACT LEAD.

NOTE 1. THE QUANTITY OF U-FL-R-SMT-1(32) IS 2500 CONNECTORS PER REEL.

2 THIS DIMENSION SHOWS THE ALLOWABLE RANGE THAT THE RESIN IS PUT OVER THE CENTER CONTACT.

3. LEAD CO-PLANARITY SHALL BE 0.1 MAX
4. FOR THE POSSIBILITY OF BREAKAGE OR DEFORMATION DO NOT MATE THIS CONNECTOR WITH PARTNER U-FL PULG BEFORE MOUNTING ON PC BOARD.
5. USE ALL COMPONENT WITHIN 6 MONTHS AFTER THE DELIVERY.
STORE IN MANUFACTURER'S PACKAGE OR TIGHTLY RE-CLOSED BOX WITH THE FOLLOWING CONDITIONS.
USE THIS PRODUCT WITHIN 6 MONTHS AFTER RECEIPT.
CHECK THE TERMINAL SOLDERABILITY BEFORE USE IF THE PRODUCT HAS BEEN STORED FOR MORE THAN 6 MONTHS.
TEMPERATURE: -10°C TO +40°C
HUMIDITY : 15 TO 85% RH.

6. ENVIRONMENT CONDITION
DO NOT USE THE PRODUCT UNDER THE ENVIRONMENTAL CONDITION AS SHOWN BELOW DUE TO POSSIBLE DETERIORATION OF PRODUCTS.

SPECIAL GAS ATMOSPHERE (HYDROGEN SULFIDE GAS, SULFUR SULFIDE GAS AND HYDROGEN SULFIDE GAS)
PLACE ATTENTION REQUIRED : HEATING SYSTEM, AREA NEAR HOT SPRING, VOLCANIC MOUNTAIN AND ALIKE
WATER SPLASHED AND CONDENSATION PLACES.
PLACE ATTENTION REQUIRED : HARSH TEMPERATURE CHANGE.

2500 CONNECTORS PER PLASTIC REEL.
RoHS COMPLIANT

2	BRASS	GOLD PLATING					
1	PHOSPHOR BRONZE	SILVER PLATING	3	LCP	(BEIGE), UL94V-0		
NO.	MATERIAL	FINISH, REMARKS	NO.	MATERIAL	FINISH, REMARKS		
UNITS	mm	SCALE	10:1	COUNT	DESCRIPTION OF REVISIONS	DESIGNED	CHECKED
APPROVED : MH. YAMANE		14.01.09		DRAWING NO.		EDC3-302540-32	
CHECKED : NK. NINOMIYA		14.01.09		PART NO.		U. FL-R-SMT-1(32)	
DESIGNED : RO. YOKOYAMA		14.01.08		CODE NO.		CL331-0472-2-32	
DRAWN : RO. YOKOYAMA		14.01.08					

Mouser Electronics

Authorized Distributor

Click to View Pricing, Inventory, Delivery & Lifecycle Information:

[Hirose Electric:](#)

[U.FL-R-SMT-1\(32\)](#)