

规格书编号

SPEC NO :

产品规格书

SPECIFICATION

CUSTOMER 客户: _____

PRODUCT 产品: _____ SAW FILTER _____

MODEL NO 型号: _____ HDF110M4 SMD-21 _____

PREPARED 编制: _____ CHECKED 审核: _____

APPROVED 批准: _____ D A T E 日期: _____ 2005-11-18 _____

客户确认 CUSTOMER RECEIVED:		
审核 CHECKED	批准 APPROVED	日期 DATE

无锡市好达电子股份有限公司
Shoulder Electronics Limited

1. SCOPE

This specification shall cover the characteristics of SAW filter With 110M used for IF applications.

2. ELECTRICAL SPECIFICATION

DC Voltage VDC	0V
AC Voltage Vpp	10V50Hz/60Hz
Operation temperature	-30°C to +60°C
Storage temperature	-45°C to +85°C
RF Power Dissipation	0dBm

Electronic Characteristics

2-1. Electrical characteristics

Parameter	Minimum	Typical	Maximum	Unit
Center Frequency Fc (between -3dB points)	109.95	110.0	110.05	MHz
Insertion loss at 110.0 MHz (Including loss in matching elements) (Excluding losses due to matching)		12 8	14 10	dB
Bnd width B_{-3dB} B_{-25dB} (Sweep:number of point 801) B_{-40dB}	940	980 1900 2800	2060 4000	KHz
Group delay ripple(p-p) (1. 50 ohm Matching; 2. Average factor >16) (3. Smoothing : On) Fc-250KHz~Fc+250KHz Fc-650KHz~Fc+650KHz		30 300	100 400	nsec.
Relative attenuation (At Fc 0 dB) Fc Fc±0.20MHz Fc±0.20KHz Fc±0.30MHz Fc±5,±6,±7,±8,±9,±10 MHz	35	0.4 0.8 47	1.0 1.5	dB
Temperature coefficient of frequency Tcf		-18		ppm/K

3. TEST CIRCUIT

Actual matching values may vary due to PCB layout and parasitics

1. Passband and relative attenuation test circuit

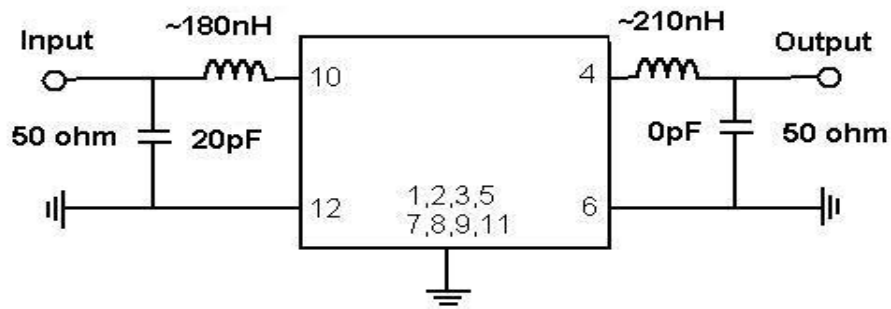

2. Group delay ripple test circuit

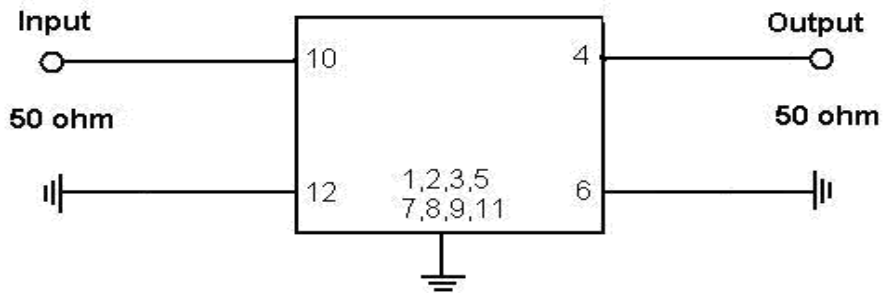

3.1. Typical frequency response

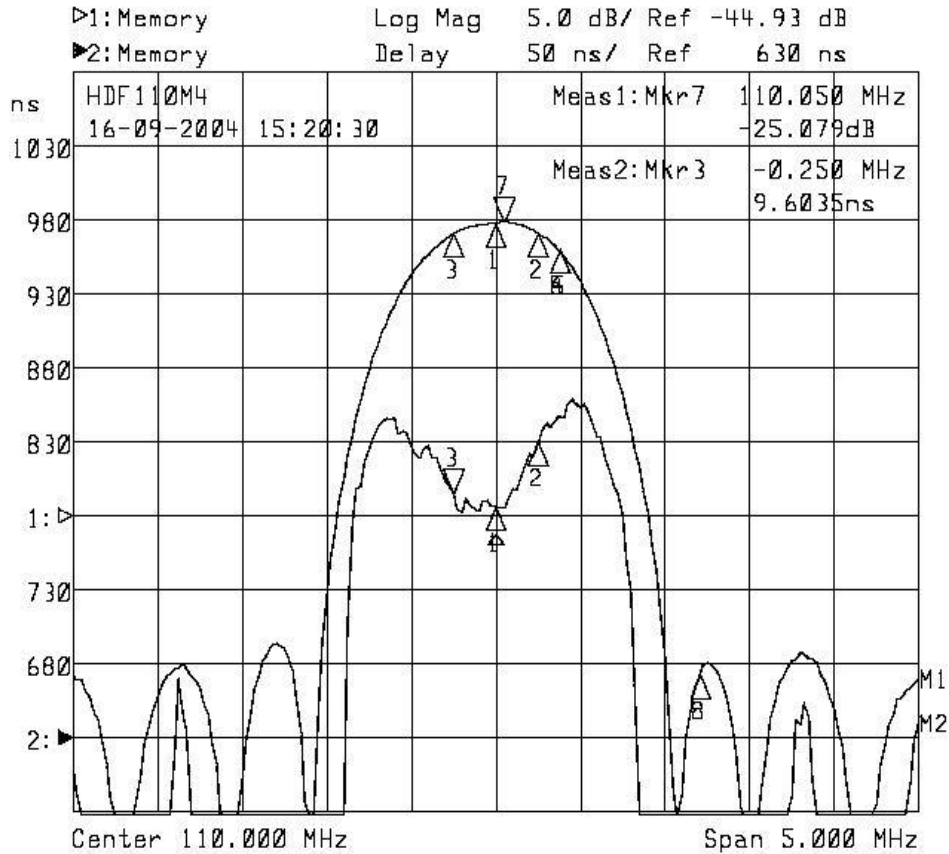
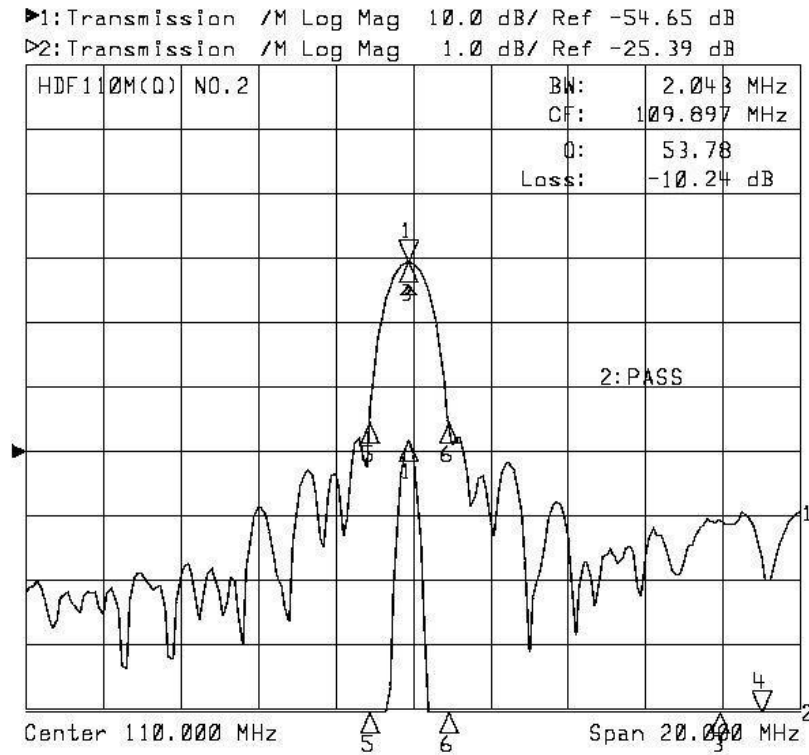

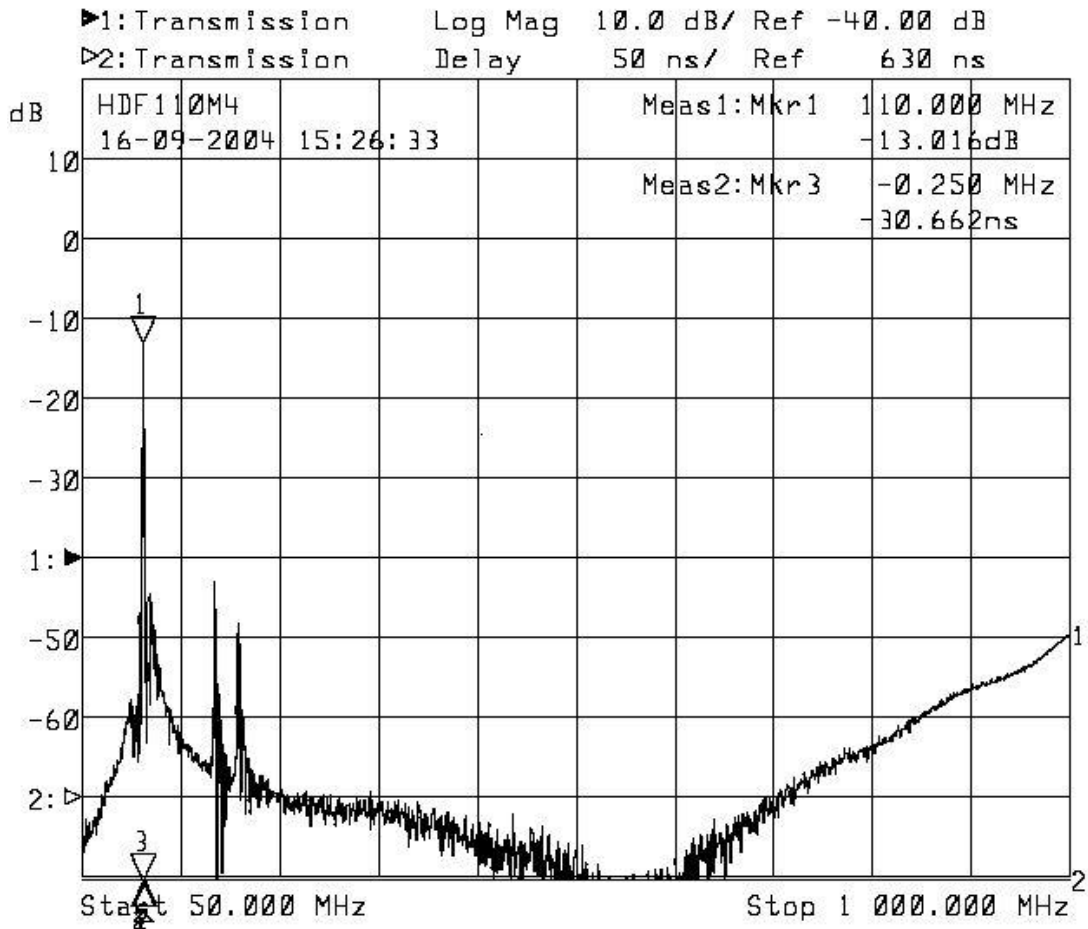

4. DIMENSION

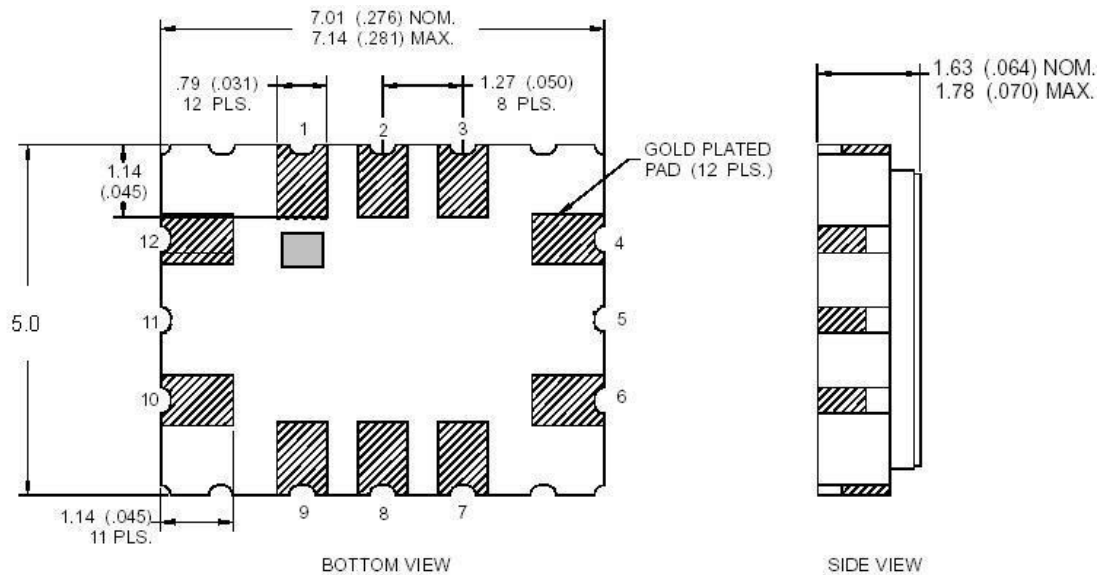

5. ENVIRONMENTAL CHARACTERISTICS

5-1 Temperature cycling

Subject the device to a low temperature of -45°C for 30 minutes. Following by a high temperature of $+25^{\circ}\text{C}$ for 5 Minutes and a higher temperature of $+85^{\circ}\text{C}$ for 30 Minutes. Then release the device into the room conditions for 1 to 2 hours prior to the measurement. It shall meet the specifications in table 1.

5-2 Resistance to solder heat

Submerge the device terminals into the solder bath at $260^{\circ}\text{C} \pm 5^{\circ}\text{C}$ for 10 ± 1 sec. Then release the device into the room conditions for 4 hours. It shall meet the specifications in table 1.

5-3 Solderability

Submerge the device terminals into the solder bath at $245^{\circ}\text{C} \pm 5^{\circ}\text{C}$ for 5s, More than 95% area of the soldering pad must be covered with new solder. It shall meet the specifications in table 1.

5-4 Mechanical shock

Drop the device randomly onto the concrete floor from the height of 1 m 3 times. the filter shall fulfill the specifications in table 1.

5-5 Vibration

Subject the device to the vibration for 2 hour each in x,y and z axes with the amplitude of 1.5 mm at 10 to 55 hz. The filter shall fulfill the specifications in table 1.

6. REMARK

6.1 Static voltage

Static voltage between signal load & ground may cause deterioration & destruction of the component. Please avoid static voltage.

6.2 Ultrasonic cleaning

Ultrasonic vibration may cause deterioration & destruction of the component. Please avoid ultrasonic cleaning

6.3 Soldering

Only leads of component may be soldered. Please avoid soldering another part of component.

7. Packing

7.1 Dimensions

(1) Carrier Tape: Figure 1

(2) Reel: Figure 2

(3) The product shall be packed properly not to be damaged during transportation and storage.

7.2 Reeling Quantity

1000 pcs/reel 7"

3000 pcs/reel 13''

7.3 Taping Structure

(1) The tape shall be wound around the reel in the direction shown below.

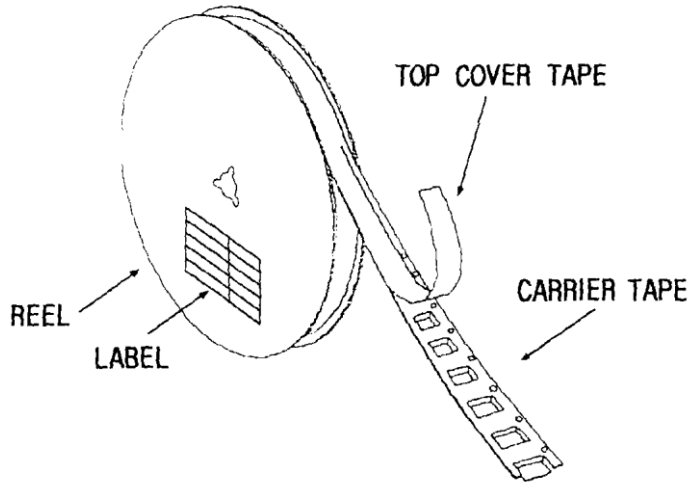

(2) Label

Device Name	
User Product Name	
Quantity	
Lot No.	

(3) Leader part and vacant position specifications.

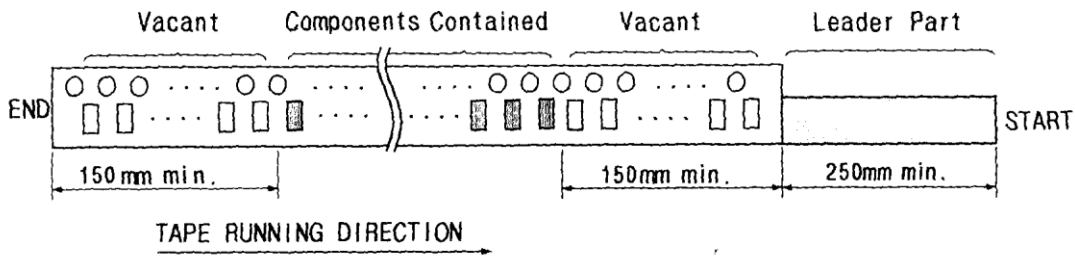

8. TAPE SPECIFICATIONS

8.1 Tensile Strength of Carrier Tape: 4.4N/mm width

8.2 Top Cover Tape Adhesion (See the below figure)

- (1) pull off angle: 0~15°
- (2) speed: 300mm/min.
- (3) force: 20~70g

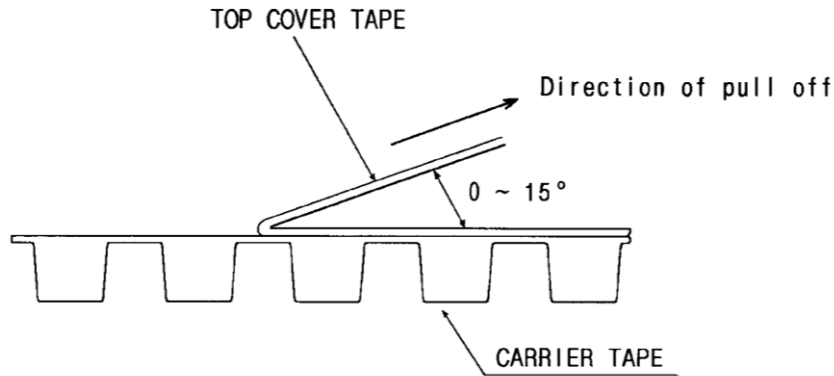

[Figure 1] Carrier Tape Dimensions

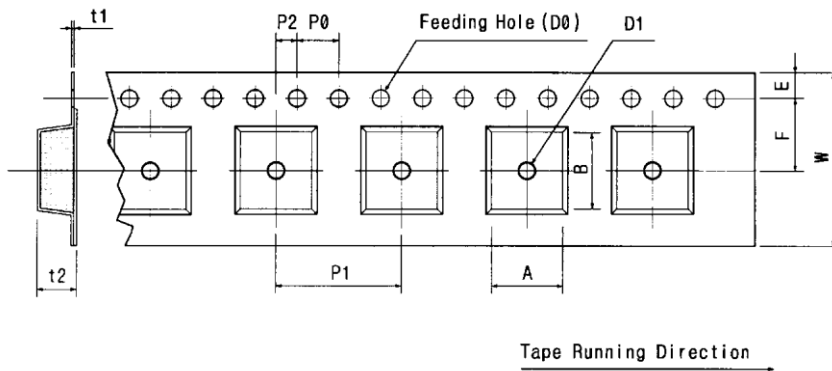

[Unit:mm]

W	F	E	P0	P1	P2	D0	D1	t1	t2	A	B
12.00	7.50	1.75	4.00	8.00	2.00	Ø1.50	Ø1.5	0.25	2.20	5.30	7.30
±0.30	±0.10	±0.10	±0.10	±0.10	±0.10		±0.25	±0.05	±0.10	±0.10	±0.10

[Figure 2]

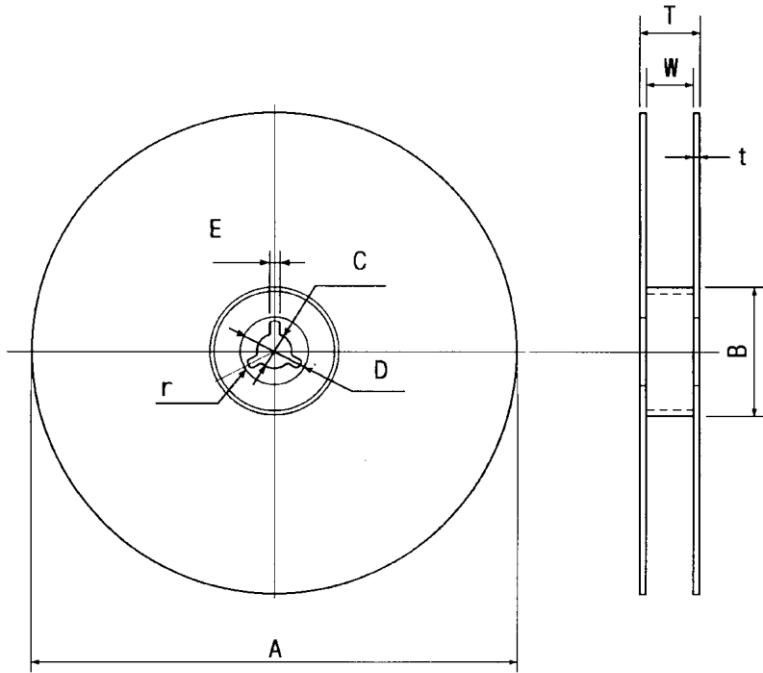

[Unit:mm]

A	B	C	D	E	W	t	r
Ø330	Ø100	Ø13	Ø21	2	16.8	3	1.0
±1.0	±0.5	±0.5	±0.8	±0.5	±0.3	max.	max.

9. CAUTION

- 9-1. This is an electrostatic sensitive device. Please avoid static voltage during operation and storage.
- 9-2. Sudden change of temperature shall be avoided, deterioration If the characteristics can occur.
- 9-3. Ultrasonic vibration may cause deterioration and destruction of the components .Please avoid ultrasonic cleaning.