

NOTES:

- MATERIALS AND FINISHES (AS PER FINISH AND CORROSION REQUIREMENTS OF MIL-C-39012):
 BODY, COUPLING NUT - NON-MAGNETIC STAINLESS STEEL, GOLD PLATE (.000004 MIN) THICK.
 OUTER FERRULE - COPPER, GOLD PLATED (.000004 MIN) THICK.
 CONTACT - BRASS OR BERYLLIUM COPPER, GOLD PLATED (.0000040 MIN) THICK.
 RETAINING RING - BERYLLIUM COPPER.
 INSULATOR - PTFE.
 GASKET - SILICONE RUBBER.
- MECHANICAL SPECIFICATIONS:
 ENGAGEMENT DESIGN: SMA PER MIL-C-39012
 MATING CYCLES: MINIMUM 500
 ENGAGEMENT TORQUE: 2 IN-LBS MAX
 COUPLING TORQUE: 7-10 IN-LBS
 COUPLING NUT RETENTION: (60 LBS)
- ELECTRICAL SPECIFICATIONS:
 IMPEDANCE: 50 OHMS
 VOLTAGE RATING: 750 VRMS PEAK
 CORONA LEVEL: 190V @ 21KM (70K FT) MIN
 VSWR: 1.20 +.025f (GHz)
 INSERTION LOSS: .03 $\sqrt{f(\text{GHz})}$ dB MAX
- CENTER CONTACT IS SUPPLIED LOOSE.

901-9511-3		REVISIONS			
DRAWING NO.	REV	DESCRIPTION	DATE	ECO	APPR
THIRD ANGLE PROJ.	A	RELEASE TO MFG.	11/17/76	24871	SP
	M	ADDED SHEET 2	4/27/04	44926	CPM
	N	BODY & CP NUT PLATE WAS PASSIVATED; FERR WAS NICKEL	7/25/05	45650	CPM
	P	SEE SHEET 1	7/10/06	46155	CPM
	R	NOTES: ADD ENGAGEMENT DESIGN, COUPLING TORQUE MAX 10 IN-LBS WAS 17, ADD COUPLING NUT RETENTION, VOLTAGE RATING 750 WAS 375, ADD CORONA LEVEL	12/10/14	50293	MJD
	T	NOTE 1 - RETAINING RING - BERYLLIUM COPPER WAS BRASS & WAX DIPPED	3/2/15	50385	MJD

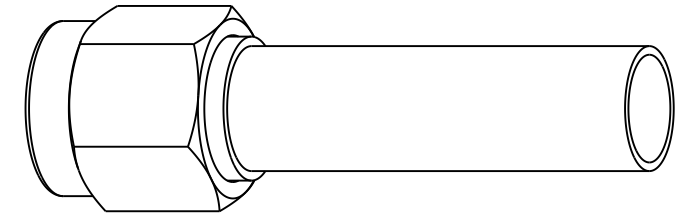

SCALE 3.000

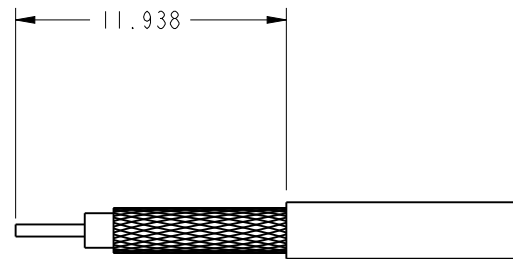
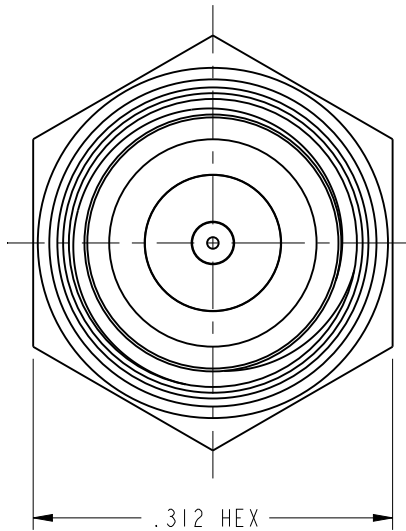

RECOMMENDED
CABLE STRIPPING DIM'S.
SCALE 3.000

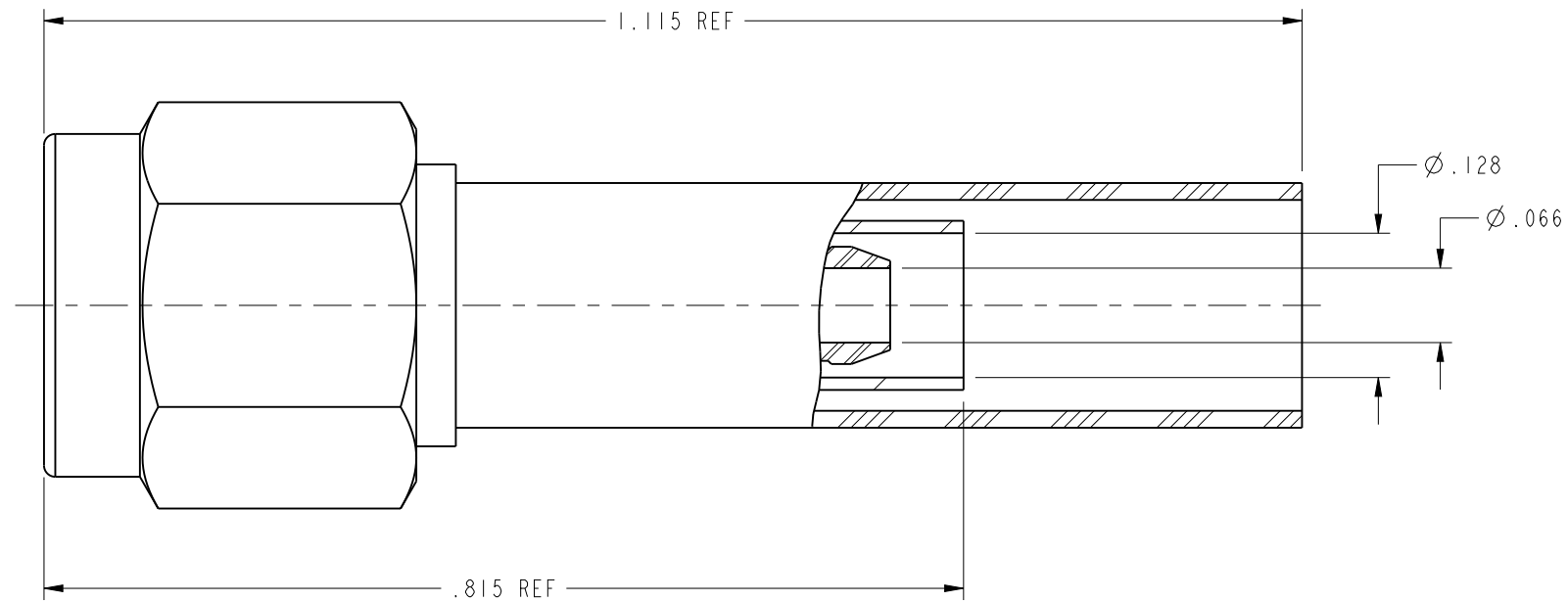

CUSTOMER OUTLINE DRAWING

ALL OTHER SHEETS ARE FOR INTERNAL USE ONLY

UNLESS OTHERWISE SPECIFIED, DIMENSIONS ARE IN INCHES AND TOLERANCES ARE: 2 PLACE DECIMAL ±.015 (0,381 mm) 3 PLACE DECIMAL ±.005 (0,127 mm) ANGLES ± 1°	MATERIAL	DRAWN C. McGRATH	DATE 4/8/04	TITLE CRIMP TYPE 'SMA' PLUG FOR RG-188A/U, 316/U, 174/U, 179B/U, & 187A/U CABLES	Amphenol RF Danbury, CT, USA Tainan, Taiwan Shenzhen, China www.amphenolrf.com		
	REFERENCE D,O,R, 313431 611X-706 GEN# ASSYM8_SMA	ENGINEER P. BRENZEL	DATE 2/13/98				
NOTICE - These drawings, specifications, or other data (1) are, and remain the property of Amphenol Corp. (2) must be returned upon request; and (3) are confidential and not to be disclosed to any person other than those to whom they are given by Amphenol Corp. The furnishing of these drawings, specifications, or other data by Amphenol Corp., or to any other person to anyone for any purpose is not to be regarded by implication or otherwise in any manner licensing, granting rights or permitting such holder or any other person to manufacture, use or sell any product, process or design, patented or otherwise, that may in any way be related to or disclosed by said drawings, specifications, or other data.	CAD FILE I:\SMA\901-9511-3		CODE ID 74868	DWG SIZE B	DRAWING NO. 901-9511-3	SCALE: 6.0:1	SHEET 2 OF 2

Mouser Electronics

Authorized Distributor

Click to View Pricing, Inventory, Delivery & Lifecycle Information:

[Amphenol:](#)

[901-9511-3](#)