

**INPUT RECTIFIER DIODE
TO-220 FULLPAK**

Description/Features

The 20ETS..FP rectifier **SAFEIR** series has been optimized for very low forward voltage drop, with moderate leakage. The glass passivation technology used has reliable operation up to 150°C junction temperature.

Typical applications are in input rectification and these products are designed to be used with International Rectifier Switches and Output Rectifiers which are available in identical package outlines. Fully isolated package ($V_{INS} = 2500 V_{RMS}$).

UL E78996 approved 

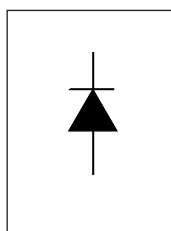

$V_F < 1V @ 10A$
$I_{FSM} = 300A$
$V_{RRM} 800 \text{ to } 1600V$

Output Current in Typical Applications

Applications	Single-phase Bridge	Three-phase Bridge	Units
Capacitive input filter $T_A = 55^\circ C, T_J = 125^\circ C$, common heatsink of $1^\circ C/W$	18	22	A

Major Ratings and Characteristics

Characteristics	20ETS..FP	Units
$I_{F(AV)}$ Sinusoidal waveform	20	A
V_{RRM}	800 to 1600	V
I_{FSM}	300	A
$V_F @ 10A, T_J = 25^\circ C$	1.0	V
T_J	-40 to 150	$^\circ C$

Package Outline

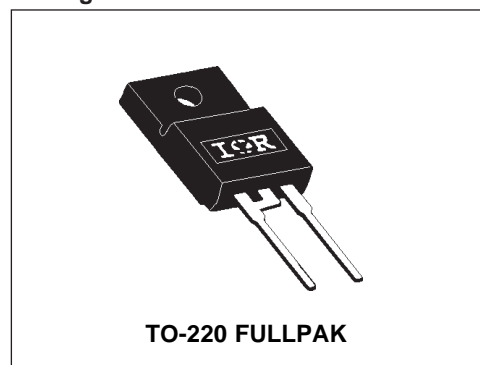

Voltage Ratings

Part Number	V_{RRM} , maximum peak reverse voltage V	V_{RSM} , maximum non repetitive peak reverse voltage V	I_{RRM} 150°C mA
20ETS08FP	800	900	1
20ETS12FP	1200	1300	
20ETS16FP	1600	1700	

Provide terminal coating for voltages above 1200V

Absolute Maximum Ratings

Parameters	20ETS..FP	Units	Conditions
$I_{F(AV)}$ Max. Average Forward Current	20	A	@ $T_C = 88^\circ\text{C}$, 180° conduction half sine wave
I_{FSM} Max. Peak One Cycle Non-Repetitive Surge Current	250	A	10ms Sine pulse, rated V_{RRM} applied
	300		10ms Sine pulse, no voltage reapplied
I^2t Max. I^2t for fusing	316	A^2s	10ms Sine pulse, rated V_{RRM} applied
	442		10ms Sine pulse, no voltage reapplied
$I^2\sqrt{t}$ Max. $I^2\sqrt{t}$ for fusing	4420	$A^2\sqrt{s}$	$t = 0.1$ to 10ms, no voltage reapplied

Electrical Specifications

Parameters	20ETS..FP	Units	Conditions
V_{FM} Max. Forward Voltage Drop	1.1	V	@ 20A, $T_J = 25^\circ\text{C}$
r_t Forward slope resistance	10.4	mΩ	$T_J = 150^\circ\text{C}$
$V_{F(TO)}$ Threshold voltage	0.85	V	
I_{RM} Max. Reverse Leakage Current	0.1	mA	$T_J = 25^\circ\text{C}$
	1.0		$T_J = 150^\circ\text{C}$

$V_R = \text{rated } V_{RRM}$

Thermal-Mechanical Specifications

Parameters	20ETS..FP	Units	Conditions
T_J Max. Junction Temperature Range	-40 to 150	$^\circ\text{C}$	
T_{stg} Max. Storage Temperature Range	-40 to 150	$^\circ\text{C}$	
R_{thJC} Max. Thermal Resistance Junction to Case	1.5	$^\circ\text{C/W}$	DC operation
R_{thJA} Max. Thermal Resistance Junction to Ambient	62	$^\circ\text{C/W}$	
R_{thCS} Typ. Thermal Resistance Case to Heatsink	1.5	$^\circ\text{C/W}$	Mounting surface, smooth and greased
wt Approximate Weight	2 (0.07)	g (oz.)	
T Mounting Torque	Min. 6 (5)	Kg-cm (lbf-in)	
	Max. 12 (10)		
Case Style	TO-220FULLPAK		(94/V0)

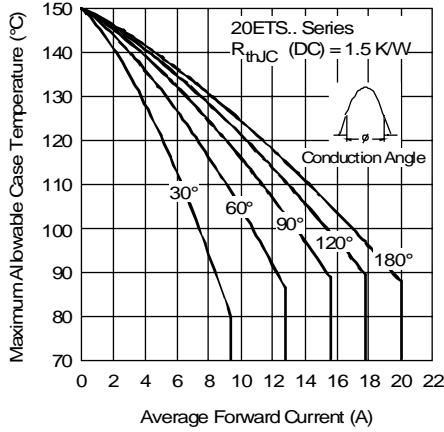

Fig. 1 - Current Rating Characteristics

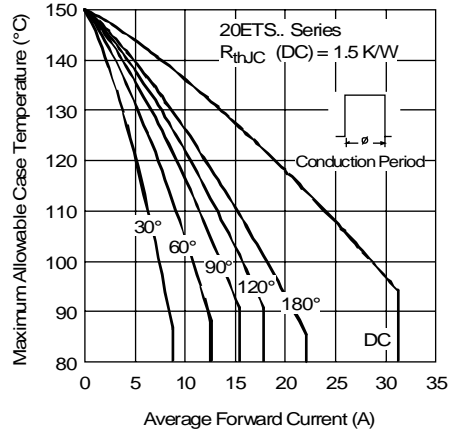

Fig. 2 - Current Rating Characteristics

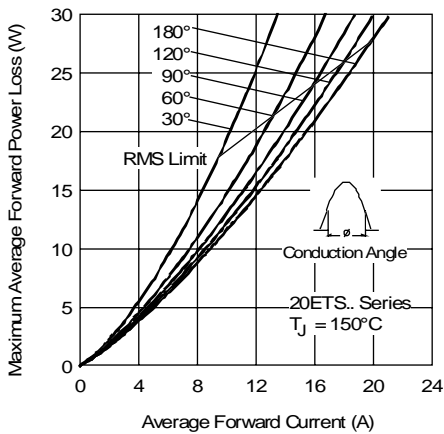

Fig. 3 - Forward Power Loss Characteristics

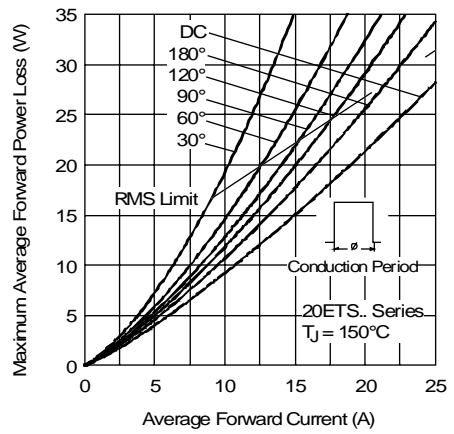

Fig. 4 - Forward Power Loss Characteristics

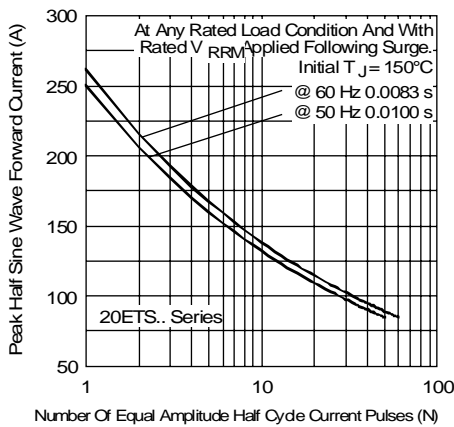

Fig. 5 - Maximum Non-Replicative Surge Current

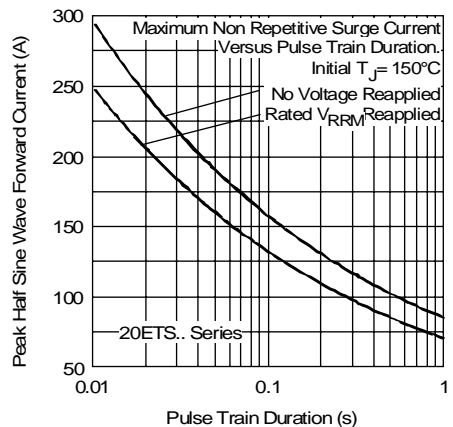

Fig. 6 - Maximum Non-Replicative Surge Current

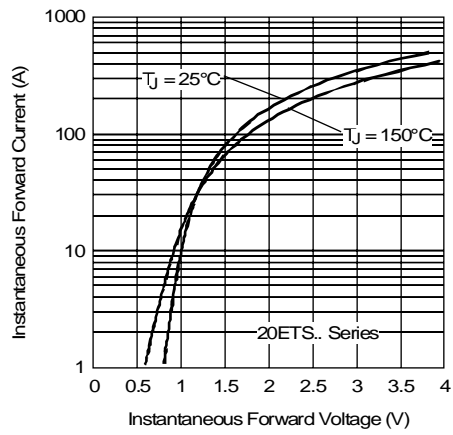

Fig.7-Forward Voltage Drop Characteristics

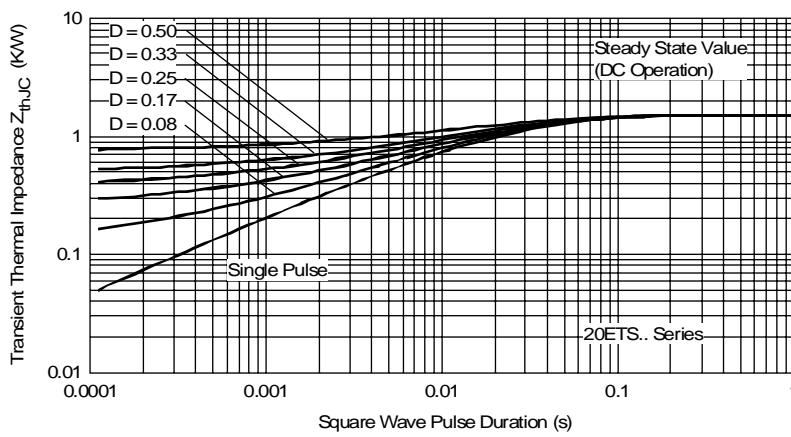
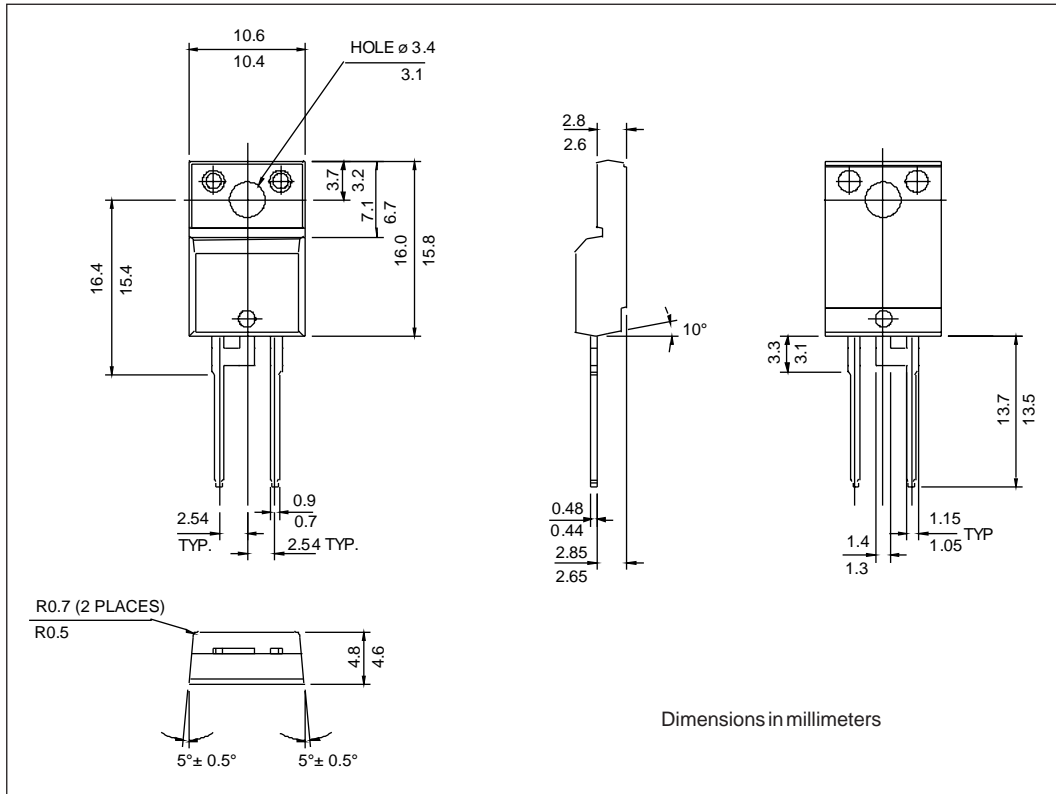
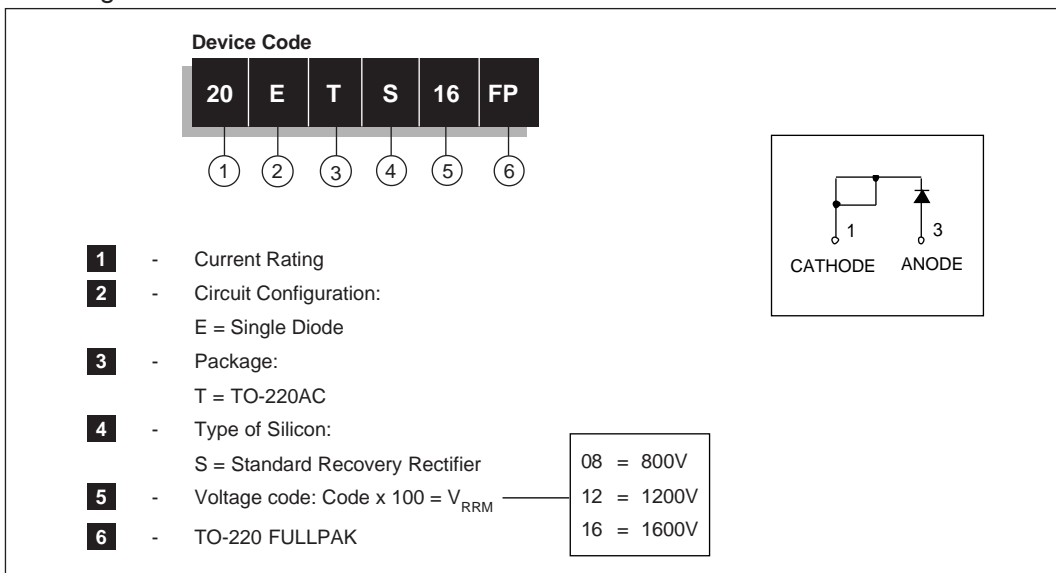

Fig. 8 - Thermal Impedance Z_{thjC} Characteristics

Outline Table



Ordering Information Table



WORLD HEADQUARTERS: 233 Kansas St., El Segundo, California 90245 U.S.A. Tel: (310) 322 3331. Fax: (310) 322 3332.
EUROPEAN HEADQUARTERS: Hurst Green, Oxted, Surrey RH8 9BB, U.K. Tel: ++ 44 1883 732020. Fax: ++ 44 1883 733408.
IR CANADA: 15 Lincoln Court, Brampton, Markham, Ontario L6T3Z2. Tel: (905) 453 2200. Fax: (905) 475 8801.
IR GERMANY: Saalburgstrasse 157, 61350 Bad Homburg. Tel: ++ 49 6172 96590. Fax: ++ 49 6172 965933.
IR ITALY: Via Liguria 49, 10071 Borgaro, Torino. Tel: ++ 39 11 4510111. Fax: ++ 39 11 4510220.
IR FAR EAST: K&H Bldg., 2F, 30-4 Nishi-Ikebukuro 3-Chome, Toshima-Ku, Tokyo, Japan 171. Tel: 81 3 3983 0086.
IR SOUTHEAST ASIA: 1 Kim Seng Promenade, Great World City West Tower, 13-11, Singapore 237994. Tel: ++ 65 838 4630.
IR TAIWAN: 16 Fl. Suite D.207, Sec. 2, Tun Haw South Road, Taipei, 10673, Taiwan. Tel: 886 2 2377 9936.