

LEW840X, OpenSource Multiple Network Gateways

Draft Ver 0.21 Mar. 2020

IP65 Gateway, Market Ready Enclosure

LEW840X Series gateways are developed for commercial, industrial, and agriculture applications. Enclosure has either Ingress Protection IP65 or IP51. An IP65 gateway can be deployed outdoor.



Multiple Network, Radio Gateways

LTE, WiFi, and Ethernet interfaces are supported simultaneously. One gateway can be deployed globally to interface with networks available locally. Operation and maintenance supports are simplified. When multiple networks are available, back-up routing can assure of cloud connection during one or more networks failures.

- nRF9160: LTE-M and NB-IoT module with GPS receiver
- ESP32M16 WiFi module: WiFi, Ethernet with Power over Ethernet
- BT840F(nRF52840): BLE 5, Thread, Zigbee (IEEE 802.15.4) module; supports mesh.
- BT40F(nRF5340): BLE5.1, Thread, Zigbee (IEEE 802.15.4) module; supports mesh, directional finding.
- LR62E (SX1262): LoRa supporting cloud connection.

Demonstration quality source codes for connecting sensors to AWS, Google, or MicroSoft cloud servers are

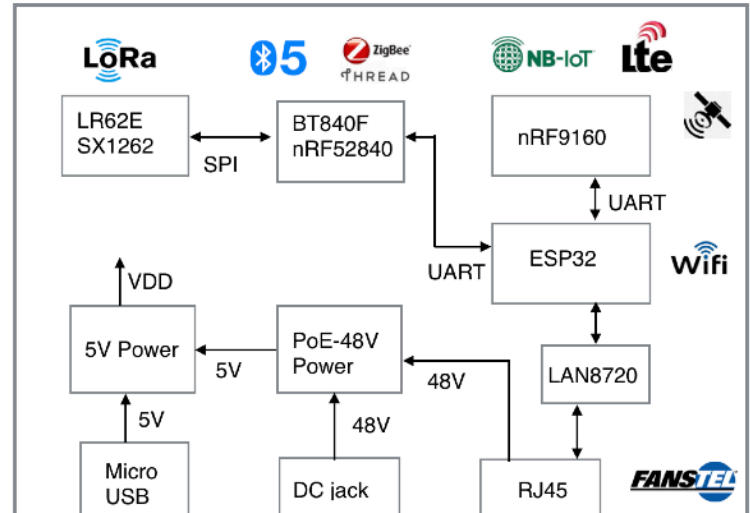

Open Source IoT Gateway supporting multiple radios, multiple networks

available. They can reduce your development time and cost, allowing shorter time to market.

Nordic nRF52840, nRF5340 and nRF9160 have CryptoCell coprocessor embedded. Secure connection can be established from Bluetooth mesh to cloud server.

Private label and custom hardware can be supported.

Some BLE 5 Gateways will be upgraded to BLE 5.1 in the near future.

MultiNetwork, MultiProtocol Gateways with Ingress Protection

Ingress protect/	IP51/black	IP51/black	IP51/black	IP51/black	IP65/white	IP65/white	IP65/white
Gateway	EW840F5	EW840F5P	LEWR840E5P	EE840XE5P	EW840F6P	LEE840E6P	LEWR840E6P
Size, mm	107x141x40	107x141x40	107x141x40	107x141x40	107x141x40	107x141x40	107x141x40
WiFi/Ethernet	ESP32M16	ESP32M16	ESP32M16	ESP32E16.	ESP32M16	ESP32E16.	ESP32M16
LTE Module			nRF9160			nRF9160	nRF9160
BLE Module	BT840F	BT840F	BT840E	BT840XE	BT840F	BT840E	BT840E
LoRa module			LR62E				LR62E
External antenna	0	0	3	2	0	3	3
PoE	No	Yes	Yes	Yes	Yes	Yes	Yes
Optional power	USB, included	USB, not included	USB, not included	USB,not included	48V, not included	48V, not included	48V, not included
Operating temp.	0°C to +40°C	-40°C to +80°C	-40°C to +80°C	-40°C to +80°C	-40°C to +85°C	-40°C to +85°C	-40°C to +85°C
Mounting	Desk, wall, pole	Desk, wall, pole	Desk, wall, pole	Desk, wall, pole	Wall, pole	Wall, pole	Wall, pole
Certifications							
QDID	108621	108621	108621	108621	108621	108621	108621
1K price, each	\$50.59	\$54.82	\$108.31	\$72.38	\$76.69	\$125.00	\$139.89
Availability	Non-stock	Sample 03/20	Sample 03/20	Sample 03/20	Non-stock	Non-stock	Non-stock

LEW840X, OpenSource Multiple Network Gateways

Table Of Contents

IP65 Gateway, Market Ready Enclosure	1
Multiple Network, Radio Gateways.....	1
1. Introduction	3
2. Specifications	4
LEW840X Part Numbers	5
LTE-M/NB-IoT Interfaces	5
WiFi or Ethernet Interfaces.....	6
Bluetooth 5, Thread, Zigbee Interfaces	7
Bluetooth 5.1, Thread, Zigbee Interfaces	8
LoRa Interfaces	9
Power Supply and Power over Ethernet.....	10
Operating Temperature Range	10
Private Label and Custom Hardware.....	10
PK-LEW840X Programming Kit.....	10
3. Firmware Development and Programming.....	11
Ethernet and WiFi	11
Programming the nRF52840 Module.	17
Programming the nRF9160 Module	20
Revision History	22
Contact Us	23

LEW840X, OpenSource Multiple Network Gateways

1. Introduction

One LEW840X Series gateway can be deployed globally to interface with networks available locally. Operation and maintenance supports are simplified. When multiple networks are available, back-up routing can assure of cloud connection during one or more networks failures.

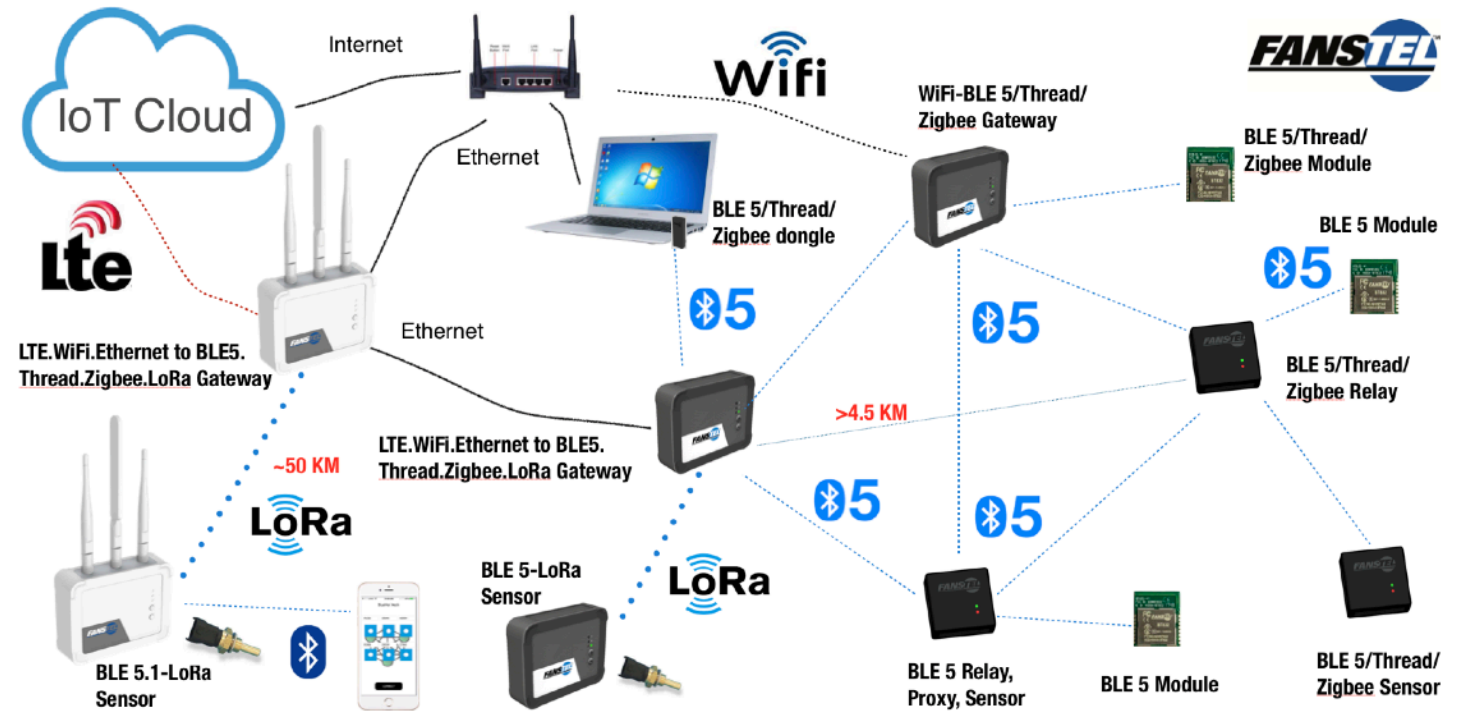

Alternatively, you can select a single network interface to reduce product cost.

LEW840X Series supports LTE-M, NB-IoT, WiFi, and Ethernet interfaces. It supports Bluetooth 5, 5.1, Thread, Zigbee, and LoRa on the device side.

2. Specifications

At the heart of LEW840X Series gateway is an ESP32M16 module with an ESP32 D0WD SoC. It has an Xtensa dual core 32 bit LX6 microprocessors, up to 600 MIPS. A Microchip LAN8720 is the Ethernet PHY interface.

ESP32 communicates with nRF9160 LTE-M/NB/IoT module using an UART interface. It also communicates with BT840F BLE 5 module using a second UART. BT840F controls LoRa module LR62E through an SPI interface.

BT840F supports 802.15.4 Thread and Zigbee radio protocols. It can be replaced with BT40F, an RF5340 module supporting BLE 5.1, Thread, and Zigbee.

Gateway can be powered by a 5V micro USB AC adapter, a 48V DC power supply, or powered through Ethernet cable

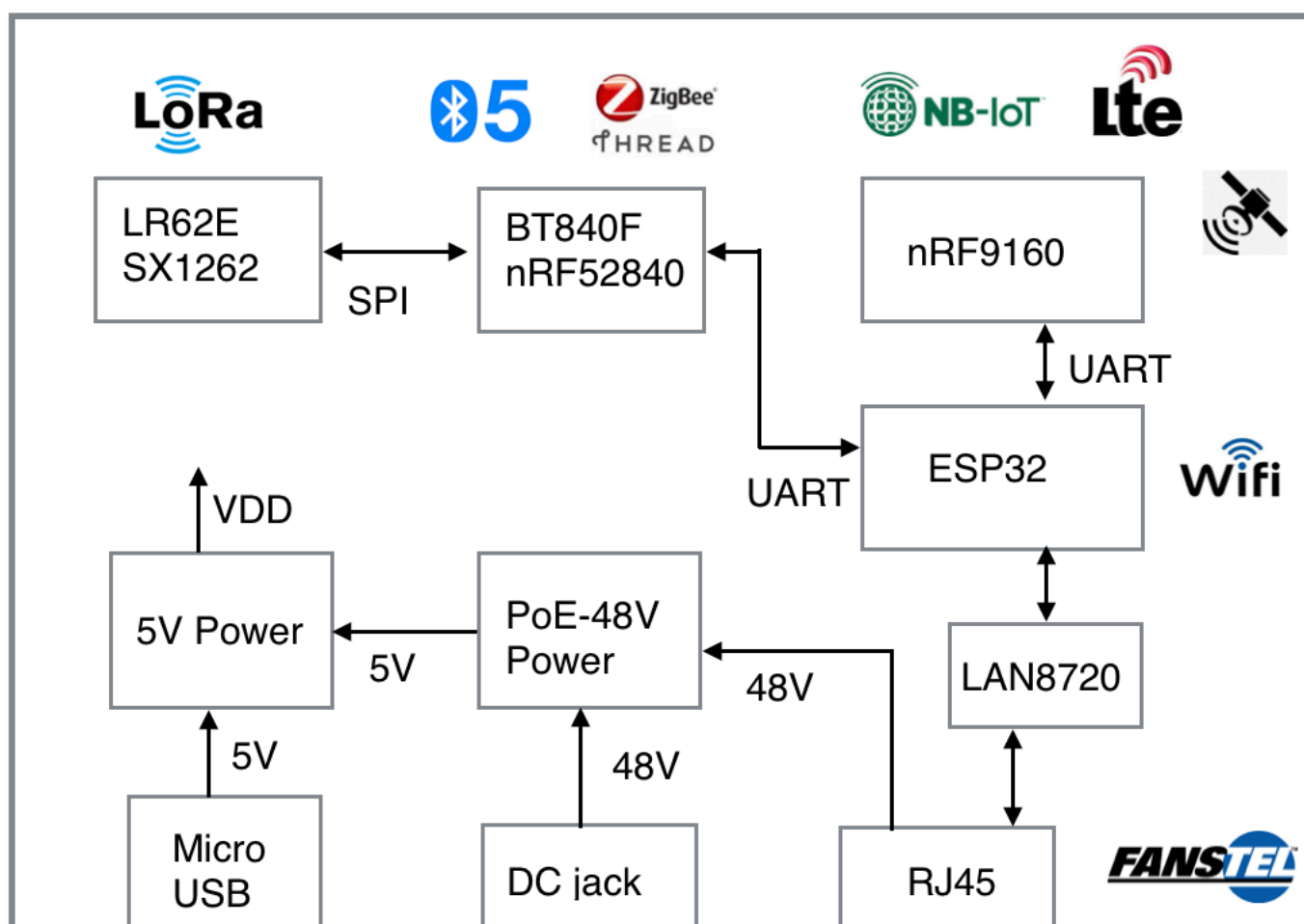

Open Source IoT Gateway supporting multiple radios, multiple networks

LEW840X, OpenSource Multiple Network Gateways

LEW840X Part Numbers

Possible part numbers of LEW840X Series are listed below.

L E W R 840E 6

L: LTE-M/NB-IoT, Nordic nRF9160; Missing: not supported

E: Ethernet, ESP32 module/LAN8720 PHY

W: WiFi with integrated antenna; **E:** WiFi with an u.FL for **E**xternal antenna.

R: LoRa, LR62E, SX1262 module; Missing: not supported.

840E: BLE 5 module, **BT840E**, **BT840F**, **BT840XE**, **BT840X**; BLE 5.1 module, **BT40E**, **BT40F**, **BT40XE**, **BT40X**.

6: IP65 Ingress Protection; **5:** IP51 Ingress Protection.

P: Power over Ethernet; Missing: PoE not supported.

- LTE-M/NB-IoT interface needs an external antenna. It is an optional feature.
- Ethernet interface is always supported.
- Bluetooth interface is supported by one of 4 BLE 5 modules or 4 BLE 5.1 modules. Module can be with an integrated antenna, with an external antenna, and with an integrated power amplifier to boost TX power to +21 dBm. IEEE 802.15.4 Thread and Zigbee interfaces are supported by BLE modules.
- WiFi interface is supported with an integrated antenna or an external antenna.
- LoRa interface is an optional feature. An external antenna is required.
- Enclosure can be IP65 or IP51 rated.
- Power over Ethernet (PoE) can be supported for all gateways. IP51 gateway without PoE is powered by a micro USB AC adapter. IP65 gateway without PoE is powered by 48V DC.
- Up to 3 external antennas can be supported. LTE and LoRa interfaces need external antennas. Integrated antenna and external antenna can be supported for both BLE and WiFi.

LTE-M/NB-IoT Interfaces

LEW840X gateway uses a Nordic nRF9160 SICA module supporting LTE-M, NB/IoT and with GPS receiver. An external LTE antenna is used. GPS receiver amplifier and antenna is integrated.

Microcontroller:

- ARM® Cortex® -M33
- 1 MB flash, 256 kB low leakage RAM
- ARM® Trustzone®
- ARM® Cryptocell 310
- Up to 4x SPI master/slave
- Up to 4x I2C compatible two-wire master/slave.
- Up to 4x UART (CTS/RTS)
- I2S
- Digital microphone interface (PDM)
- 4x pulse width modulator (PWM) unit
- 12-bit, 200 ksps ADC - 8 configurable channels with programmable gain
- 3x 32-bit timer with counter mode
- 2x real-time counter (RTC)
- Programmable peripheral interconnect (PPI)
- 32 general purpose I/O pins

LTE modem:

- Transceiver and baseband

LEW840X, OpenSource Multiple Network Gateways

- 3GPP LTE release 13 Cat-M1 and Cat-NB1 compliant
 - 3GPP release 13 coverage enhancement
- 3GPP LTE release 14 Cat-NB2 compliant
- GPS receiver
 - GPS L1 C/A supported
 - GPS antenna and amplifier integrated
- RF transceiver for global coverage
 - Up to 23 dBm output power
 - -108 dBm sensitivity (LTE-M) for low band, -107 dBm for mid band
 - An u.FL connector for external LTE antenna
- LTE band support in hardware:
 - Cat-M1: B1, B2, B3, B4, B5, B8, B12, B13, B14, B17, B18, B19, B20, B25, B26, B28, B66
 - Cat-NB1/NB2: B1, B2, B3, B4, B5, B8, B12, B13, B17, B18, B20, B25, B26, B28, B66
- Nano SIM card connector on-board.
- Power saving features: DRX, eDRX, PSM
- IP v4/v6 stack
- Secure socket (TLS/DTLS) API

WiFi or Ethernet Interfaces

ESP32M16 WiFi module with an Expressif ESP32 D0WD, dual core Xtensa 32 bit processor establishes and maintains connection to a cloud server.

Mongoose OS OpenSource codes for connecting to Fanstel development server and to **Google Cloud IoT Core, AWS, and Microsoft** cloud servers are available. They can be used as a base to develop interface with other servers.

Link to download additional document and source codes:

<http://www.fanstel.com/download-opensource/>

Brief descriptions of WiFi module ESP32M16:

- Expressif ESP32 D0WD, Xtensa dual core 32 bit LX6 microprocessors, up to 600 MIPS.
- 448KB ROM, 520KB SRAM, 16 MB flash
- 16KB SRAM in RTC
- 802.11 b/g/n, 802.11n (2.4 GHz), up to 150 Mbps

LEW840X, OpenSource Multiple Network Gateways

Bluetooth 5, Thread, Zigbee Interfaces

Bluetooth 5 module supports Bluetooth 5, Thread, and Zigbee radio interfaces. It also manages LoRa module LR62E. One of four Bluetooth 5 modules can be installed.

- BT840F, an nRF52840 module. It is FCC certified with max. TX power of +8.46 dBm.
- BT840E, an nRF52840 module with an u.FL connector, panel mounted SMA connector for an external antenna. It passes FCC certification testing with ANT060, a 6 dBi antenna.
- BT840X, an nRF52840 module with SKY66112 power amplifier. It passes FCC testings at +21 dBm TX.
- BT840XE, an nRF52840 + SKY66112 module with an u.FL connector, panel mounted SMA connector for an external antenna. It passes FCC testings with ANT000, a 0 dBi antenna.

Maximum TX power of BT840X is about 13.8 dB higher than that of BT840F. The receiver gain of SKY66112 is measured at 1.5 dB. Comparing to BT840F, BT840X has 15 dB more link budget. In free space (antenna high above ground and without obstruction), 15 dB link budget can more than quadruple range. Or, it is enough to penetrate 2 dry walls in typical house in the U.S.A.



If you are developing a mesh network or sensor using BT840X/XE, a gateway with BT840X/XE will provide the longest possible Bluetooth, Thread or Zigbee range.

If this gateway is to receive data from various (Fanstel and non Fanstel) sensors, beacons, BT840E with ANT060 antenna will provide the best receiver sensitivity if antennas are deployed in parallel (horizontal polarization).

Brief specifications of BT840F Series modules.

- nRF52840 QIAA, ARM Cortex M4F, 64 MHz
- ARM® TrustZone® Cryptocell-310 co-processor
- BLE 5 data rate: 2Mbps, 1Mbps, 500kbps, 125kbps.
- IEEE 802.15.4 Thread and Zigbee data rate: 250 Kbps
- 2.4 GHz proprietary data rate: 2 Mbps, 1 Mbps
- Serial Wire Debug (SWD)
- Nordic SoftDevice Ready
- Over-the-Air (OTA) firmware update
- Flash/RAM: 1MB/256KB.
- 48 General purpose I/O pins
- Type 2 NFC-A tag with wake-on field, Touch-to-pair support
- Integrated PCB trace antenna or u.FL connector

module	BT840F	BT840E	BT840X	BT840XE
SoC	nRF52840-QIAA	nRF52840-QIAA	nRF52840-QIAA	nRF52840-QIAA
Size	15x20.8x1.9mm	14x16x1.9mm	15x28.0x1.9mm	15x28.0x1.9mm
BT Antenna	PCB trace	ANT060	PCB trace + PA	PA+ANT000
Max TX includes antenna gain	+8.8dBm	+14.4 dBm	+22.6 dBm	+21.0 dBm
32.768 sleep crystal	External	External	Integrated	Integrated
BT range, 1 Mbps, LMPI	1000 meters		1170 meters	1170 meters
BT range, 1Mbps, 1.52m	390 meters		900 meters	1170 meters
BT range, 125 Kbps, LMPI.	2300 meters	3400 meters, est.	>4500 meters	>4500 meters
BT range, 125 kbps, 1.52m	640 meters		1240 meters	1920 meters
FCC ID	X8WBT840F	X8WBT840F	X8WBT840X	X8WBT840X
IC ID	4100A-BT840F	4100A-BT840F	4100A-BT840X	4100A-BT840X
CE	Certified	Certified	Certified	Certified
RCM	Certified	Certified	Certified	Certified
TELEC	201-190710/00	201-190710/00		
Availability	Production	Production	Production	Production

LEW840X, OpenSource Multiple Network Gateways

Bluetooth 5.1, Thread, Zigbee Interfaces

Bluetooth 5.1 module supports Bluetooth 5, Thread, and Zigbee radio interfaces. It also manages LoRa module LR62E. One of Bluetooth 5.1 modules can be installed.

- BT40F, an nRF5340 module.
- BT40E, an nRF5340 module with an u.FL connector, panel mounted SMA connector for an external antenna.
- BT40X, an nRF52840 module with nRF21540 power amplifier.
- BT40XE, an nRF52840 + nRF21540 module with an u.FL connector, panel mounted SMA connector for an external antenna.

Nordic nRF5340 SoC has a dual core ARM Cortex™ M33 MCU. BT40F Series modules are footprint compatible with BT840F series. Firmware configuration of GPIO pins is required.

The application core ARM Cortex™ M33 can operate at 128 MHz. It has a Floating Point Unit (FPU) and hardware DSP instruction sets. It can handle Bluetooth profiles needing processing power, e.g., BLE 5.1 directional finding, audio.

Brief Specifications BT40F Series modules.

- nRF5340 QKAA, dual core ARM® Cortex M33
- Application Core
 - 128/64 MHz Cortex M33 with FPU and DSP instructions
 - 1MB flash, 512KB RAM
 - 8KB 2-way set associate cache
 - ARM® TrustZone® Cryptocell-312 co-processor
- Network core:
 - 64 MHz Cortex M33 with 2KB instruction cache
 - 256KB flash, 64KB RAM
 - 2.6 mA in RX and 3.2 mA in 0dBm TX
 - Receiver Sensitivity: -97.5 dBm at 1Mbps
 - TX power: programmable +3dBm to -20dBm
 - BLE 5.1 data rate: 2Mbps, 1Mbps, 500kbps, 125kbps.
 - IEEE 802.15.4 data rate: 250 Kbps
 - 2.4 GHz proprietary data rate: 2 Mbps, 1 Mbps
- Serial Wire Debug (SWD)
- Nordic SoftDevice Ready
- Over-the-Air (OTA) firmware update
- Type 2 NFC-A tag with wake-on field, Touch-to-pair support

module	BT40F	BT40E	BT40X	BT40XE
SoC	nRF5340	nRF5340	nRF5340	nRF5340
Size	15x20.8x1.9mm	14x16x1.9mm	15x28.0x1.9mm	15x28.0x1.9mm
BT Antenna	PCB trace	u.FL	PCB trace + PA	PA + u.FL
Max TX				
Operating temp.	-40°C to +105°C	-40°C to +105°C	-40°C to +105°C	-40°C to +105°C
Availability	Sample 03/20	Sample 04/20	Sample 3Q20	Sample 3Q20

LEW840X, OpenSource Multiple Network Gateways

LoRa Interfaces

- LR62E module with Semtech SX1262 transceiver, u.FL connector.
- Up to +22 dBm transceiver (USA version) at 902 to 928 MHz.
- Panel mounted SMA connector for external antenna
- LoRa stacks for cloud connection are managed by BT840F Series or BT40F Series BLE modules.

LEW840X, OpenSource Multiple Network Gateways

Power Supply and Power over Ethernet

- Most of USB AC adapter has operating temperature range of 0°C to +40°C. AC adapter included in non-PoE IP51 gateway has this operating temperature range.
- A gateway with PoE can be powered by an PoE switch at up to 328 feet or 100 meters away.
- Fanstel single line PoE power injector, POE048 can power a gateway from 100 meters or 328 feet away. POE048 includes an AC adapter operating from -20°C to +60°C.
- IP65 enclosure has a barrel type, IP67 DC jack.

Operating Temperature Range

BLE 5 Gateways

Electronic components used in BLE 5 gateways has minimum operating temperature range of -40°C to +85°C. The followings limit operating temperature of gateways.

- Operating temperature range of USB AC adapter is 0°C to +40°C. Non PoE IP51 gateway includes an USB AC adapter. Operating temperature range is 0°C to +40°C.
- The enclosure material (ABS) used in IP51 gateway has operating temperature range, -40°C to +80°C. PoE IP51 gateway has operating temperature range of -40°C to +80°C.
- Operating temperature range of 48V DC power supply is -20°C to +60°C. Non PoE IP65 gateway has operating temperature range of -20°C to +60°C.
- The enclosure material (Sabic EXL9330) used in IP65 gateway has operating temperature range to over 125°C. PoE IP65 gateway has operating temperature range of -40°C to +85°C.

BLE5.1 Gateways

ESP32M16 and BLE 5.1 modules have operating temperature range of -40°C to +105°C. LTE module, LoRa module, and LAN8720 Ethernet PHY has operating temperature range of -40°C to +85°C. It is possible to develop limited feature gateway to operate to 105°C.

Private Label and Custom Hardware

Logo and button names are printed on a membrane. They can be customized.

Custom enclosure design and electronic hardware are available. Please contact [Fanstel](#).

PK-LEW840X Programming Kit

To load firmware into LEW840X Series gateway, a Programming Kit PK-LEW840X is required. In addition, you need the following hardware:

- nRF52840-DK, Development Kit for nRF52840 modules. Or, nRF5340-DK, Development Kit for nRF5340 modules.
- nRF9160-DK if you have LTE interface

LEW840X, OpenSource Multiple Network Gateways

3. Firmware Development and Programming

LEW840X gateways is pre-loaded with WiFi+Ethernet+LTE M (Optional) demonstration codes.

When connected to internet, LEW840X gateway sends temperature and humidity sensor data to Fanstel MQTT server. You can use Fanstel MQTT PC tool or mobile APP to monitor data.

MQTT tool or MQTT APP<->MQTT broker <->LEW840F<->BLE Sensor

It is easier to test gateway and load firmware by removing gateway PCBA from enclosure.

Ethernet and WiFi

Check the Ethernet.

- Connect UART_Bridge Board “TO WIFI(ESP)” into the JS1 of LEW840X PCBA.
- Make sure the switch on Bridge board is turn off.
- Connect micro USB to PC and open the terminal tool.

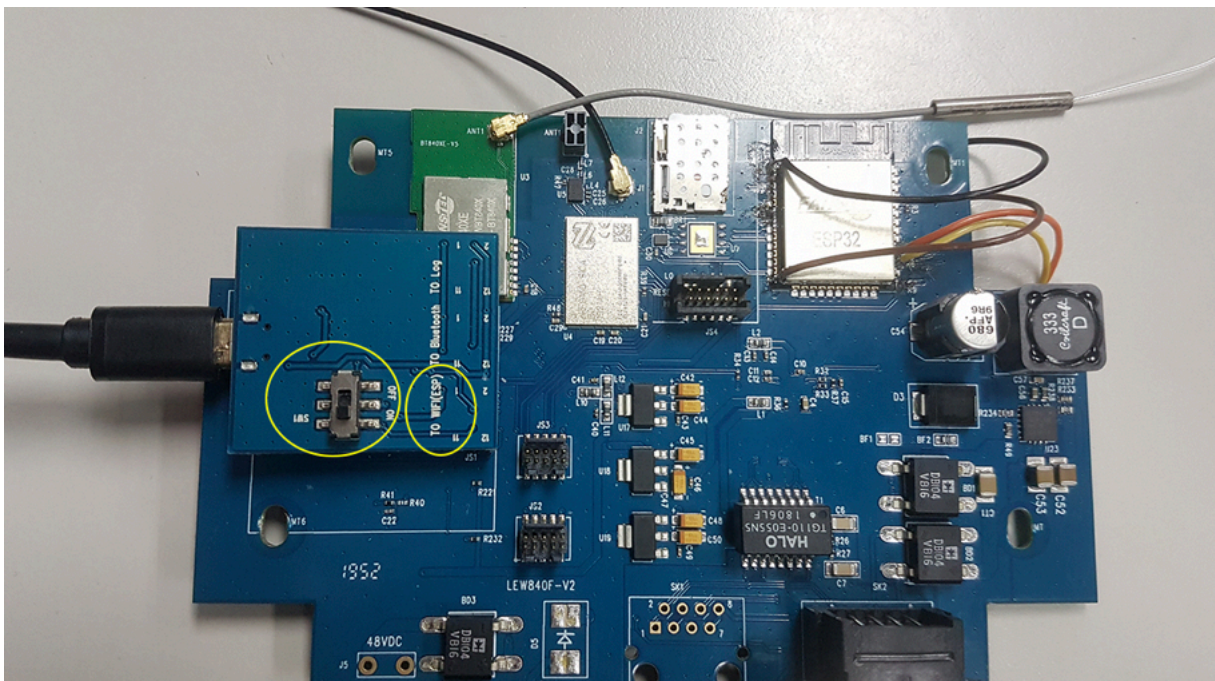

LEW840X, OpenSource Multiple Network Gateways

- Plug in the Ethernet and reset the board.
- Gateway should get DHCP IP address.

```
esp32_bt_gap.c:100      BT device name esp32_ED5509, addr 45:b5:82:9c:06:ff,2<LF>
esp32_bt_gatts.c:394   Starting BT service 5f6d4f53-5f44-4247-5f53-56435f49445f<LF>
esp32_bt_gap.c:280     BLE advertising started<LF>
esp32_bt_gatts.c:394   Starting BT service 5f6d4f53-5f52-5043-5f53-56435f49445f<LF>
mgos_net.c:85          WiFi STA: connecting<LF>
== Net event: 1313166337 WiFi CONNECTING <LF>
mgos_provision_state:43 Current state: 0 -> 1<LF>
mgos_provision_state:72 Setting provisioning timeout for 300 seconds<LF>
I (2859) wifi: state: assoc -> init (400)<LF>
I (2869) wifi: n:4 0, o:4 0, ap:255 255, sta:4 0, prof:1<LF>
mgos_wifi.c:119        WiFi STA: Disconnected, reason: 4<LF>
mgos_net.c:81          WiFi STA: disconnected<LF>
== Net event: 1313166336 WiFi DISCONNECTED <LF>
mgos_net.c:89          ETH: connected<LF>
== Net event: 1313166338 WiFi CONNECTED <LF>
[ESC]+[0:32mI (5569) event: eth ip: 192.168.0.188, mask: 255.255.255.0, gw: 192.168.0.1<ESC>+[0m<LF>
mgos_net.c:101         ETH: ready, IP 192.168.0.188, GW 192.168.0.1, DNS 192.168.0.1<LF>
== Net event: 1313166339 WiFi GO1 IP <LF>
mgos_provision_state:43 Current state: 1 -> 2<LF>
esp32_bt.c:82          Network is up, disabling Bluetooth<LF>
mgos_sys_config.c:174  Saved to conf9.json<LF>
mgos_mqtt.c:427        MQTT connecting to 59.124.228.194:1883<LF>
mgos_mqtt.c:141        MQTT TCP connect ok (0)<LF>
mgos_mqtt.c:182        MQTT CONNACK 0<LF>
online =true <LF>
mgos_provision_state:43 Current state: 2 -> 3<LF>
mgos_provision_state:66 Reached stable state (3)<LF>
mgos_sys_config.c:174  Saved to conf9.json<LF>
mgos_mqtt.c:125        Subscribing to 'esp32_ED5509/Idemo' (QoS 1)<LF>
mgos_mqtt.c:125        Subscribing to 'esp32_ED5509/rpc/#' (QoS 1)<LF>
mgos_mqtt.c:125        Subscribing to 'esp32_ED5509/rpc' (QoS 1)<LF>
Waiting Sensor data! <LF>
```

Check WiFi, setup network first.

- Hold SW1 when resetting.
- The LEW840X will enter AP mode.
- Use a smartphone and into the Setup-WiFi ..
- FanstelGW_XXXXX appear.
- Connect it and open browser goto 192.168.4.1.

LEW840X, OpenSource Multiple Network Gateways

Setup the SSID and password for your router.

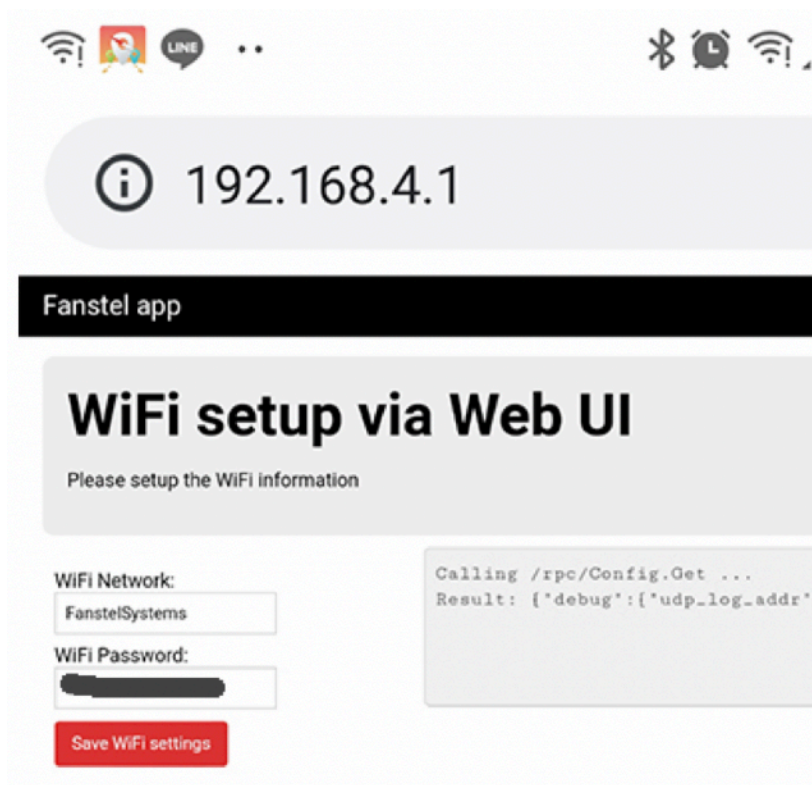

LEW840X, OpenSource Multiple Network Gateways

Check the log.

The WiFi should be got ID and connected.

```
(1219) WiFi module type: 0x1f
<LF>
mgos_aws_shadow.c:571 MQTT is not configured for AWS, not initialising shadow<LF>
mgos_mongoose.c:66 New heap free LWM: 49080<LF>
mgos_ota_core.c:1308 UID: 0fdc9367f3c35a3a, license: none<LF>
esp32_bt_gap.c:100 BT device name esp32_ED5509, addr 64:c3:47:68:ef:6e,2<LF>
esp32_bt_gatts.c:394 Starting BT service 5f6d4f53-5f44-4247-5f53-56435f49445f<LF>
esp32_bt_gap.c:280 BLE advertising started<LF>
esp32_bt_gatts.c:394 Starting BT service 5f6d4f53-5f52-5043-5f53-56435f49445f<LF>
mgos_wifi.c:136 WiFi STA: Connected, BSSID 00:1e:58:36:e3:c3 ch 4 RSSI -42<LF>
mgos_net.c:85 WiFi STA: connecting<LF>
== Net event: 1313166337 WiFi CONNECTING <LF>
mgos_provision_state:15 Current state: 0 -> 1<LF>
mgos_provision_state:72 Setting provisioning timeout for 300 seconds<LF>
mgos_net.c:89 WiFi STA: connected<LF>
== Net event: 1313166338 WiFi CONNECTED <LF>
<ESC>+[0;32mI (2579) event: sta ip: 192.168.0.189, mask: 255.255.255.0, gw: 192.168.0.1<ESC>+[0m<LF>
mgos_net.c:101 WiFi STA: ready, IP 192.168.0.189, GW 192.168.0.1, DNS 192.168.0.1<LF>
== Net event: 1313166339 WiFi GOT_IP <LF>
mgos_provision_state:18 Current state: 1 -> 2<LF>
esp32_bt.c:82 Network is up, disabling Bluetooth<LF>
mgos_sys_config.c:174 Saved to conf9.json<LF>
mgos_mqtt.c:427 MQTT connecting to 59.124.228.194:1883<LF>
mgos_mqtt.c:141 MQTT TCP connect ok (0)<LF>
mgos_mqtt.c:182 MQTT CONNACK 0<LF>
online =true <LF>
```

Check MQTT

Connect UART_Bridge Board "To Log" into the JS1.

Open the MQTT PC tool and type the ID.

The ID is esp32_XXXXXX and same as AP name.

You should able see the ID in the log.

The temperature and humidity was send to MQTT broker and publish to PC tool.

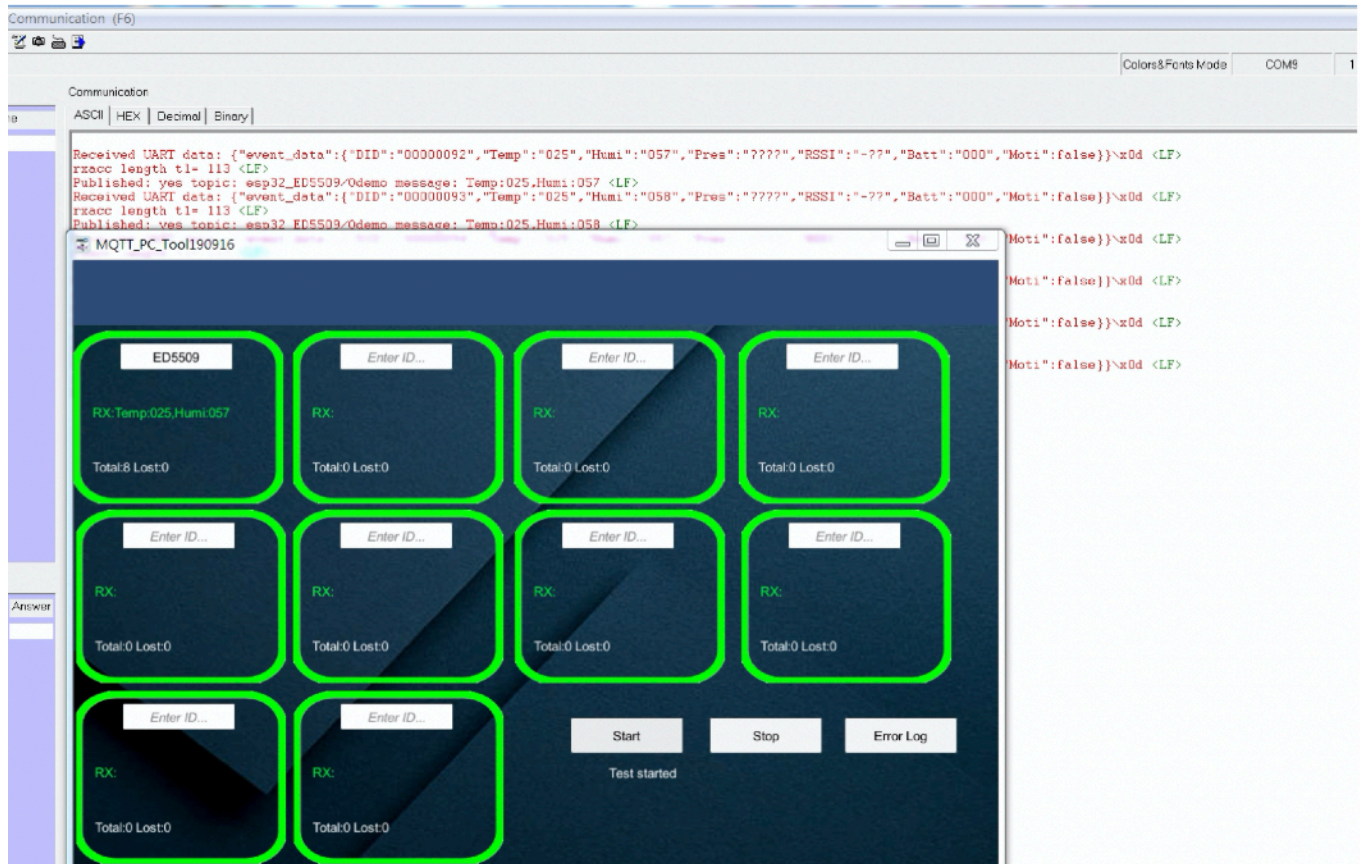

Build and programming ESP32 firmware.
 Open mos.yml in folder mqtt_sensorWiFi_Ethernet_esp32
 Change the SSID and password to match your router.
 - ["wifi.sta.ssid", "FanstelSystems"]
 - ["wifi.sta.pass", "1234567890"]
 Save the file and go to command line tool.
 use command "mos build - -platform esp32"

```
C:\mos\mqtt_sensorWiFi_Ethernet_esp32>mos build --platform esp32
Connecting to https://mongoose.cloud, user test
Uploading sources (17866 bytes)
Firmware saved to C:\mos\mqtt_sensorWiFi_Ethernet_esp32\build\fw.zip
```

LEW840X, OpenSource Multiple Network Gateways

Programming the ESP32.

Connect UART_Bridge Board "TO WIFI(ESP)" into the JS1.

Make sure the switch on Bridge board is turn on.

Type command "mos flash - -port COM9"

The port number is up to your PC.

```
C:\mos\mqtt_sensorWiFi_Ethernet_esp32>mos flash --port COM9
Loaded mqtt_sensorWiFi_Ethernet_esp32/esp32 version 1.0 (20190916-061723)
Opening COM9 @ 115200...
Connecting to ESP32 ROM, attempt 1 of 10...
  Connected, chip: ESP32D0WDQ6 R1
Running flasher @ 921600...
  Flasher is running
Flash size: 16777216, params: 0x024f (dio,128m,80m)
Flash encryption: disabled, scheme: None
Secure boot: disabled
Deduping...
  22848 @ 0x1000 -> 0
  3072 @ 0x8000 -> 0
  16384 @ 0x9000 -> 12288
  8192 @ 0xd000 -> 0
  1559408 @ 0x10000 -> 0
  262144 @ 0x190000 -> 110592
Writing...
  12288 @ 0x9000
  12288 @ 0x190000
  4096 @ 0x194000
  8192 @ 0x19a000
  8192 @ 0x1ae000
  16384 @ 0x1b5000
  61440 @ 0x1ba000
Wrote 122880 bytes in 1.58 seconds (609.14 KBit/sec)
Verifying...
  22848 @ 0x1000
  3072 @ 0x8000
  16384 @ 0x9000
  8192 @ 0xd000
  1559408 @ 0x10000
  262144 @ 0x190000
Booting firmware...
All done!
```

Programming the nRF52840 Module.

Connected nRF52 DK debug out to LEW840F JS2

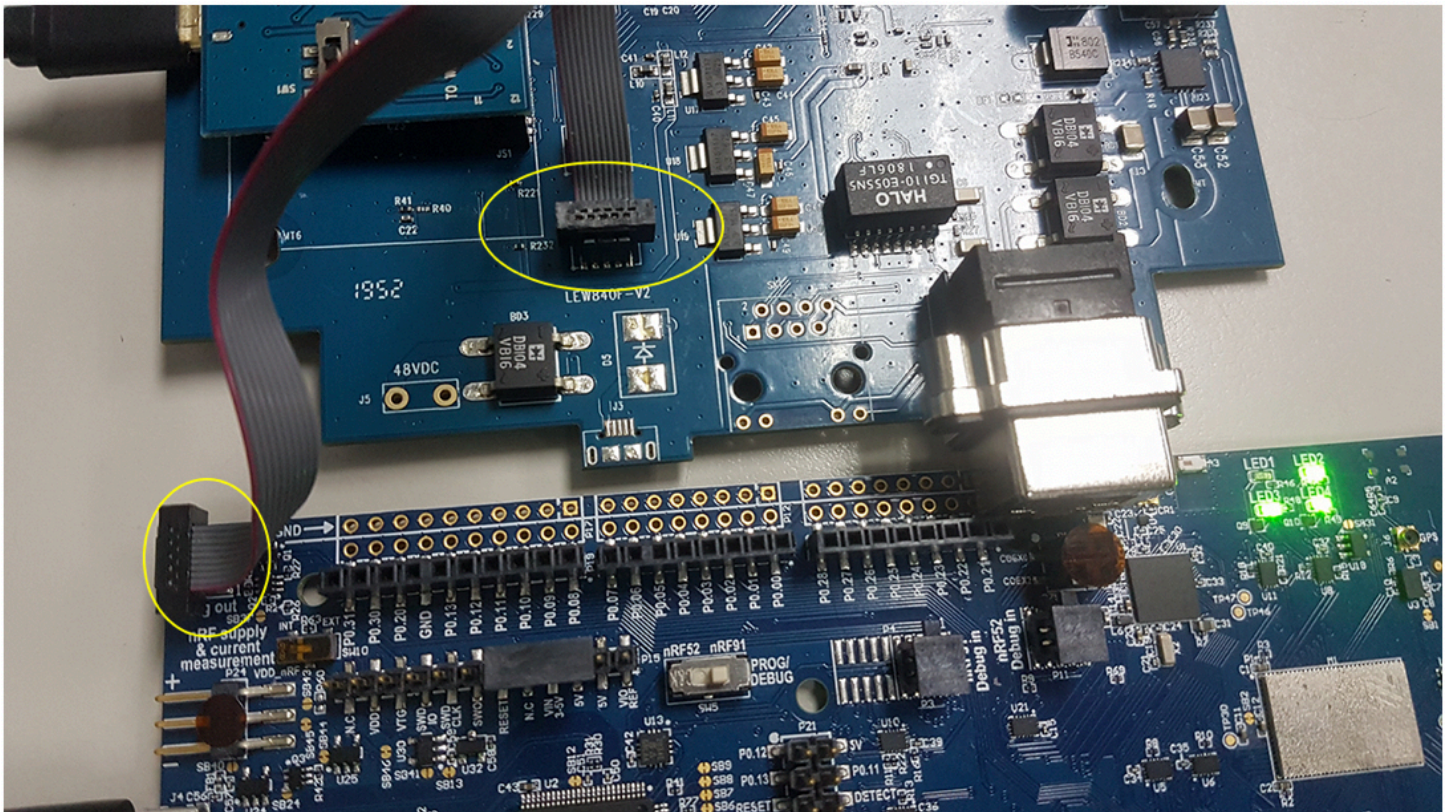

Download and install Nrf5x-Command-Line Tools

<https://www.nordicsemi.com/Software-and-Tools/Development-Tools/nRF5-Command-Line-Tools>

Download the nRF Connect desk top version

<https://www.nordicsemi.com/Software-and-Tools/Development-Tools/nRF-Connect-for-desktop>

LEW840X, OpenSource Multiple Network Gateways

Draft Ver 0.21 Mar. 2020

Open nRF connect /programmer and load the softdevice and application.
Erase and write.

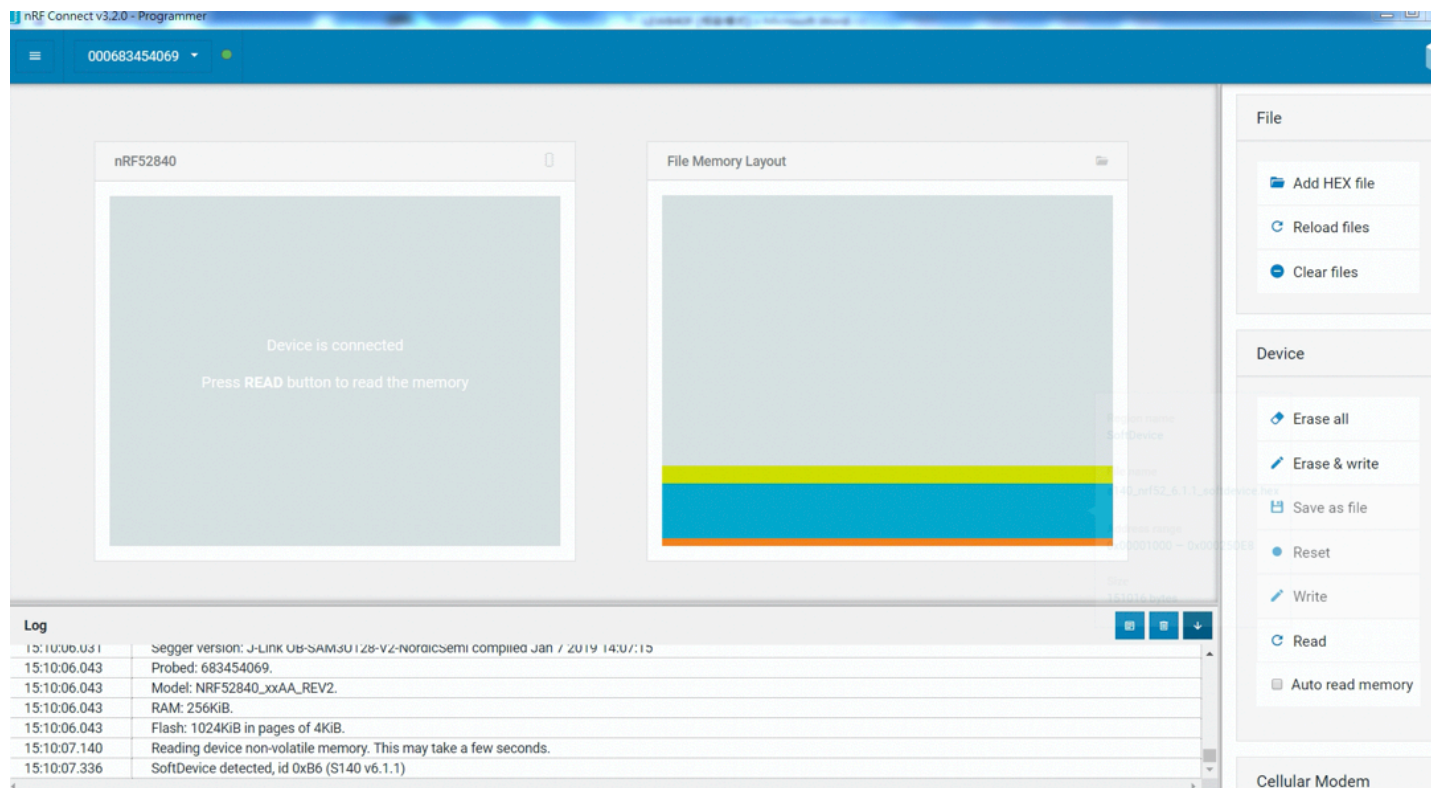

Nordic Development Environment

Nordic Semiconductor provides a complete range of hardware and software development tools for the nRF52 Series devices. nRF52840 DK board is recommended for firmware development. Document and Software development tools can be downloaded by the following links.

Get start with Nordic chip and all online documents.

http://infocenter.nordicsemi.com/index.jsp?topic=/com.nordic.infocenter.nrf52/dita/nrf52/development/nrf52_dev_kit.html&cp=1_1

Nordic SDK with many example projects.

https://developer.nordicsemi.com/nRF5_SDK/

Nordic development zone. You can search or ask a question there.

<https://devzone.nordicsemi.com/tutorials/b/getting-started/posts/development-with-gcc-and-eclipse>

Programming the Nordic chip

Download and install Nrf5x-Command-Line Tools

<https://www.nordicsemi.com/eng/nordic/Products/nRF52840/nRF5x-Command-Line-Tools-Win32/58850>

LEW840X, OpenSource Multiple Network Gateways

Download and install nRF Connect

https://www.nordicsemi.com/?sc_itemid={B935528E-8BFA-42D9-8BB5-83E2A5E1FF5C}

LEW840X, OpenSource Multiple Network Gateways

Programming the nRF9160 Module

Connected nRF9160 DK debug out to LEW840F JS3

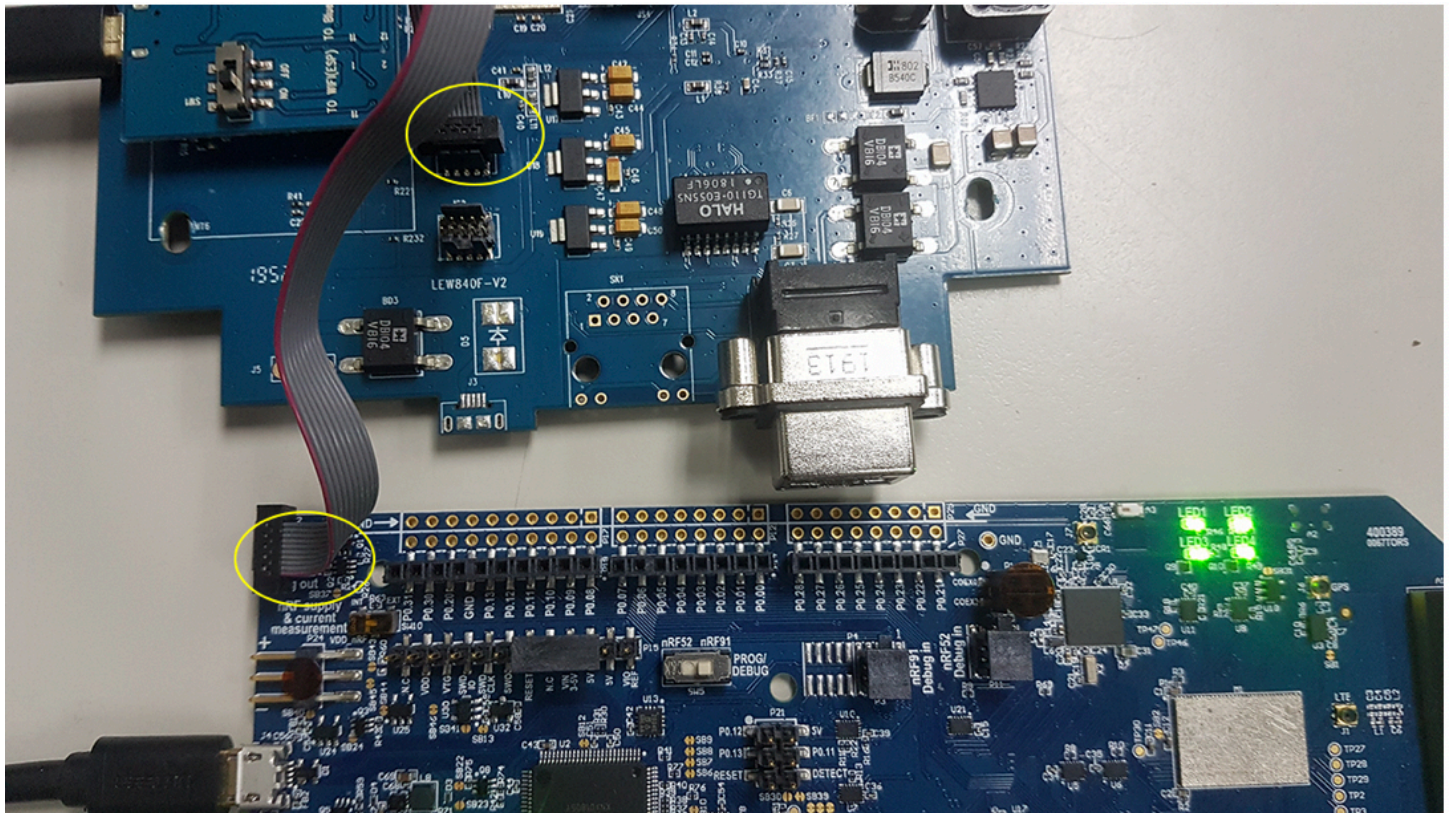

Open nRF connect /programmer and load the softdevice and application.

Erase and write.

The MQTT ID for nRF9160 is always started at "91".

LEW840X, OpenSource Multiple Network Gateways

For example the ESP32 ID is 6CA674
The Nrf9160 ID is 91A674.



Arduino ESP32 driver

<https://github.com/espressif/arduino-esp32/blob/master/docs/arduino-ide/windows.md>

Mongoose quick start guide.

<https://mongoose-os.com/docs/mongoose-os/quickstart/setup.md>

<https://mongoose-os.com/docs/mongoose-os/quickstart/develop-in-c.md>

Mongoose forum

<https://community.mongoose-os.com/>

Nordic online document.

https://infocenter.nordicsemi.com/index.jsp?topic=/com.nordic.infocenter.nrf52/dita/nrf52/development/nrf52_dev_kit.html&cp=1_1

Nordic SDK

https://developer.nordicsemi.com/nRF5_SDK/nRF5_SDK_v15.x.x/

Nordic development zone

<https://devzone.nordicsemi.com/>

All pre-loaded and test tools .

<https://www.dropbox.com/sh/i5i3iluw2mkexs7/AADYfNmQ2eC7gmI3f7gU6Npla?dl=0>

LEW840X, OpenSource Multiple Network Gateways

Revision History

- Jan. 2020, Ver. 0.10: Initial draft release
- Feb. 2020, Ver. 0.20: Add draft programming information
- Mar. 2020, Ver 0.21: Update sample stock table

LEW840X, OpenSource Multiple Network Gateways

Contact Us

United States:

Fanstel Corp.

7466 E. Monte Cristo Ave. Scottsdale AZ 85260

Tel. 1 480-948-4928

Fax. 1-480-948-5459

Email: info@fanstel.com

Website: www.fanstel.com

Taiwan:

Fanstel Corp.

10F-10, 79 Xintai Wu Road

Xizhu, New Taipei City, Taiwan 22101

泛世公司

臺灣省新北市汐止區新臺五路79號10樓之10, 22101

Tel. 886-2-2698-9328

Fax. 886-2-2698-4813

Email: info@fanstel.com

Website: www.fanstel.com

China:

Fanstel Technologies Corp.

11 Jiale Street

Ping-Dih, Long-Gang, Shen Zhen, GD 518117

泛世康科技(深圳)有限公司

廣東省深圳市龍崗區坪地鎮佳樂街11號

Tel. 86-755-8409-0928

Fax. 86-755-8409-0973

QQ. 3076221086

Email: info@fanstel.com

Website: www.fanstel.com